

2.4 GHz High-Linearity Power Amplifier

SST12LP10



EOL Data Sheet

FEATURES:

- **High Gain:**
 - >26 dB gain across 2.4~2.5 GHz over temperature 0°C to +80°C
- **High linear output power:**
 - ~27 dBm P1dB
 - Meets 802.11g OFDM ACPR requirement up to 23 dBm
 - Over 20 dBm linear output with total system EVM<5% for 54 Mbps 802.11g signal
 - Meets 802.11b ACPR requirement up to 24 dBm
- **High power-added efficiency/Low operating current for both 802.11g/b applications**
 - ~19% @ P_{OUT} = 20 dBm for 802.11g
 - ~30% @ P_{OUT} = 24 dBm for 802.11b
- **Ultra-low Reference Current**
 - ~3 mA Total I_{REF}
- **Low idle current**
 - ~60 mA I_{CQ}
- **High-speed power-up/down**
 - Turn on/off time (10%~90%) <100 ns
 - Typical power-up/down delay with driver delay included <200 ns
- **High temperature stability**
 - ~1 dB gain/power variation between 0°C to +80°C
- **Low shut-down current (< 0.1 μA)**
- **Simple input/output matching**
- **Packages available**
 - 16-contact VQFN (3mm x 3mm)
 - Non-Pb (lead-free) packages available

APPLICATIONS:

- WLAN (IEEE 802.11g/b)
- Home RF
- Cordless phones
- 2.4 GHz ISM wireless equipment

PRODUCT DESCRIPTION

The SST12LP10 is a high-performance power amplifier based on the highly-reliable InGaP/GaAs HBT technology.

The SST12LP10 can be easily configured for high-power, high-efficiency applications with superb power-added efficiency while operating over the 2.4~2.5 GHz frequency band. It provides over 26 dB gain with 19% power-added efficiency @ P_{OUT} = 20 dBm for 802.11g and 30% power-added efficiency @ P_{OUT} = 24 dBm for 802.11b.

The SST12LP10 has excellent linearity (over 20 dBm linear output with total system EVM<5%) which is essential for 54 Mbps 802.11g operation.

The power amplifier IC also features easy board-level usage along with high-speed power-up/down control and ultra-low reference current (~3 mA). These features coupled with low operating current make the SST12LP10 ideal for the final stage power amplification in battery-powered 802.11g/b WLAN transmitter applications.

The SST12LP10 is offered in 16-contact VQFN package. See Figure 1 for pin assignments and Table 1 for pin descriptions.



2.4 GHz High-Linearity Power Amplifier SST12LP10

EOL Data Sheet

FUNCTIONAL BLOCKS

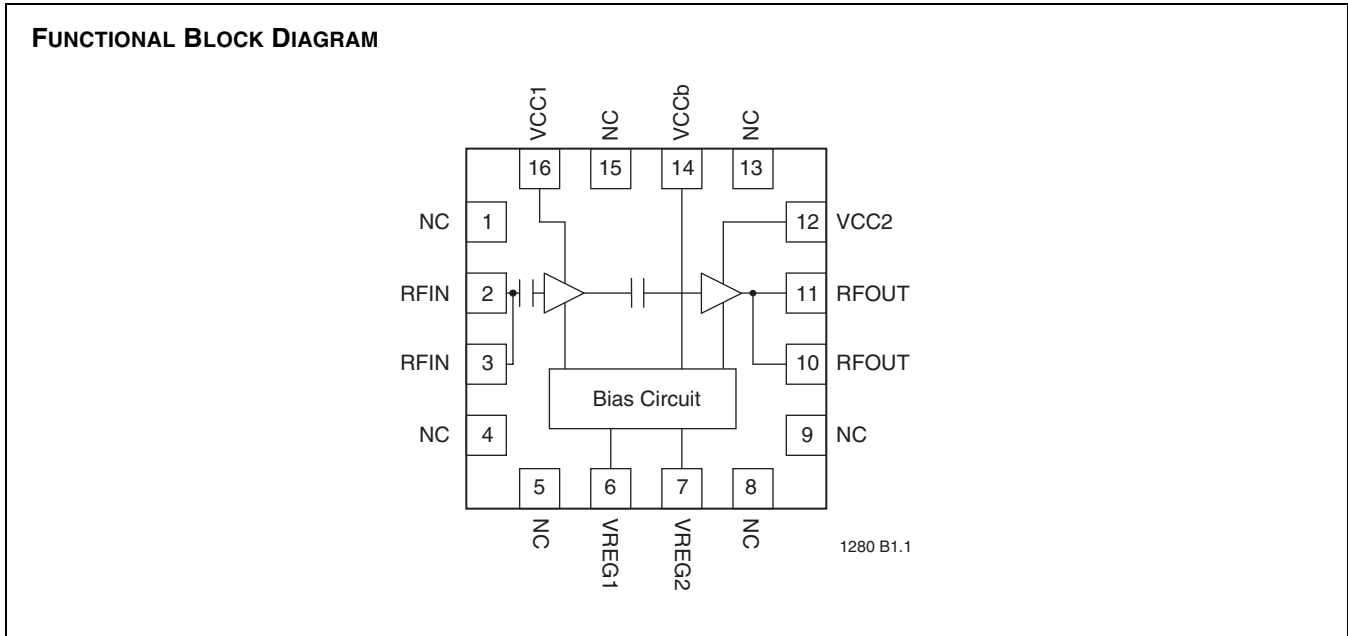

PIN ASSIGNMENTS

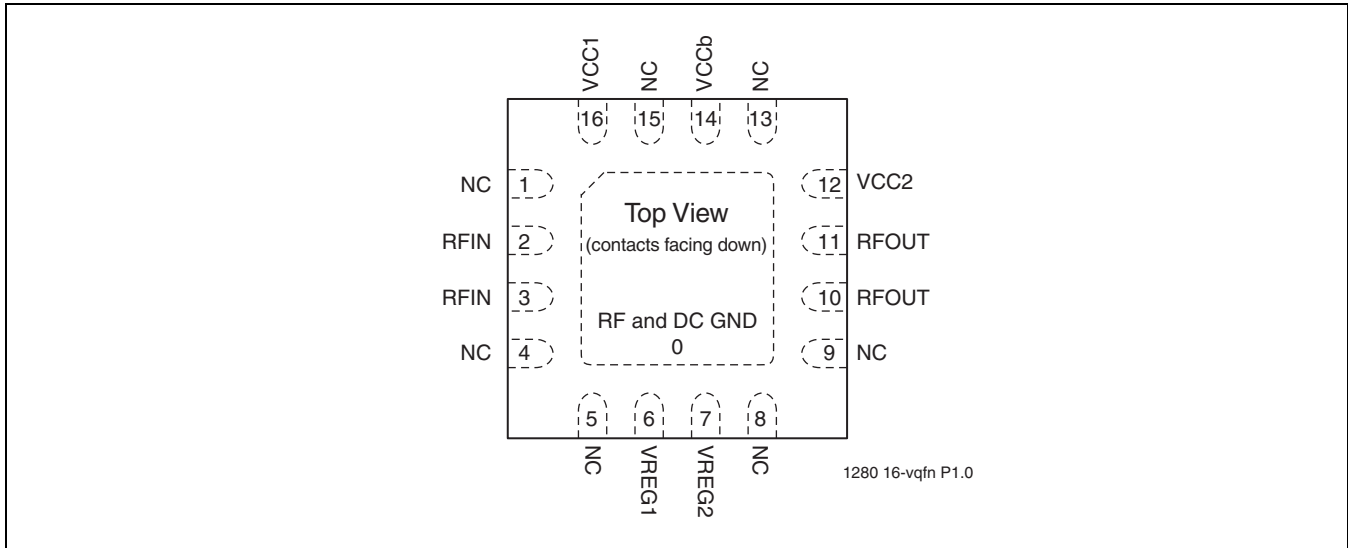

FIGURE 1: PIN ASSIGNMENTS FOR 16-CONTACT VQFN

PIN DESCRIPTIONS

TABLE 1: Pin Description

Symbol	Pin No.	Pin Name	Type ¹	Function
GND	0	Ground		The center pad should be connected to RF ground with several low inductance, low resistance vias.
NC	1	No Connection		Unconnected pins.
RFIN	2		I	RF input, DC decoupled
RFIN	3		I	RF input, DC decoupled
NC	4	No Connection		Unconnected pins.
NC	5	No Connection		Unconnected pins.
VREG1	6		PWR	1st stage idle current control
VREG2	7		PWR	2nd stage idle current control
NC	8	No Connection		Unconnected pins.
NC	9	No Connection		Unconnected pins.
RFOUT	10		O	RF output
RFOUT	11		O	RF output
VCC2	12	Power Supply	PWR	Power supply, 2nd stage
NC	13	No Connection		Unconnected pins.
VCCb	14	Power Supply	PWR	Supply voltage for bias circuit
NC	15	No Connection		Unconnected pins.
VCC1	16	Power Supply	PWR	Power supply, 1st stage

1. I=Input, O=Output



2.4 GHz High-Linearity Power Amplifier SST12LP10

EOL Data Sheet

ELECTRICAL SPECIFICATIONS

The AC and DC specifications for the power amplifier interface signals. Refer to Table 2 for the DC voltage and current specifications. Refer to Figures 2 through 11 for the RF performance.

Absolute Maximum Stress Ratings (Applied conditions greater than those listed under “Absolute Maximum Stress Ratings” may cause permanent damage to the device. This is a stress rating only and functional operation of the device at these conditions or conditions greater than those defined in the operational sections of this data sheet is not implied. Exposure to absolute maximum stress rating conditions may affect device reliability.)

Input power to pins 2 and 3 (P_{IN})	+5 dBm
Average output power (P_{OUT})	+28 dBm
Supply Voltage at pins 12, 14, 16 (V_{CC})	-0.3V to +4.6V
Reference voltage to pins 6 (V_{REF1}) and pin 7 (V_{REF2})	-0.3V to +3.6V
DC supply current (I_{CC})	500 mA
Operating Temperature (T_A)	-40°C to +85°C
Storage Temperature (T_{STG})	-40°C to +120°C
Maximum Junction Temperature (T_J)	+150°C
Surface Mount Solder Reflow Temperature:	“with-Pb” units ¹ : 240°C for 3 seconds
	“non-Pb” units: 260°C for 3 seconds

1. Certain “with-Pb” package types are capable of 260°C for 3 seconds; please consult the factory for the latest information.

OPERATING RANGE

Range	Ambient Temp	V _{CC}
Industrial	-40°C to +85°C	3.3V

TABLE 2: DC Electrical Characteristics

Symbol	Parameter	Min.	Typ	Max.	Unit	Test Conditions
V_{CC}	Supply Voltage at pins 12, 14, 16	3.0	3.3	4.2	V	
I_{CC}	Supply Current					
	for 802.11g, 20 dBm		160		mA	
	for 802.11g, 23 dBm		230		mA	
	for 802.11b, 24 dBm		270		mA	
I_{CQ}	Idle Current					
	for both 802.11b/g to meet EVM @ 20.5 dBm		70		mA	
	for only 802.11b to meet ACPR @ 22 dBm		50		mA	
I_{OFF}	Shut down current		<0.1		μA	
V_{REG1}	Reference Voltage for 1st Stage, without drop resistor		2.70		V	
V_{REG2}	Reference Voltage for 2nd Stage, without drop resistor		2.70		V	

T2.0 1280



2.4 GHz High-Linearity Power Amplifier SST12LP10

EOL Data Sheet

TABLE 3: AC Electrical Characteristics for Configuration

Symbol	Parameter	Min.	Typ	Max.	Unit
f_{L-U}	Frequency range	2400		2500	MHz
P_{OUT}	Output power				
	@ PIN = -4 dBm 11b signals	22			dBm
	@ PIN = -2 dBm 11b signals	24			dBm
	@ PIN = -8 dBm 11g signals	18			dBm
	@ PIN = -6 dBm 11g signals	20			dBm
G	Small signal gain	26			dB
G_{VAR1}	Gain variation over band (2400~2485 MHz)			1	dB
G_{VAR2}	Gain ripple over channel (20 MHz)		0.2		dB
ACPR	Meet 11b spectrum mask		24		dBm
	Meet 11g OFDM 54 MBPS spectrum mask		23		dBm
Added EVM	@ 20.5 dBm output with 11g OFDM 54 MBPS signal		3	3.5	%
2f, 3f, 4f, 5f	Harmonics at 22 dBm, without trapping capacitors			<-40	dBc

T3.0 1280



2.4 GHz High-Linearity Power Amplifier SST12LP10

EOL Data Sheet

TYPICAL PERFORMANCE CHARACTERISTICS

TEST CONDITIONS: $V_{CC} = 3.3V$, $T_A = 25^\circ C$

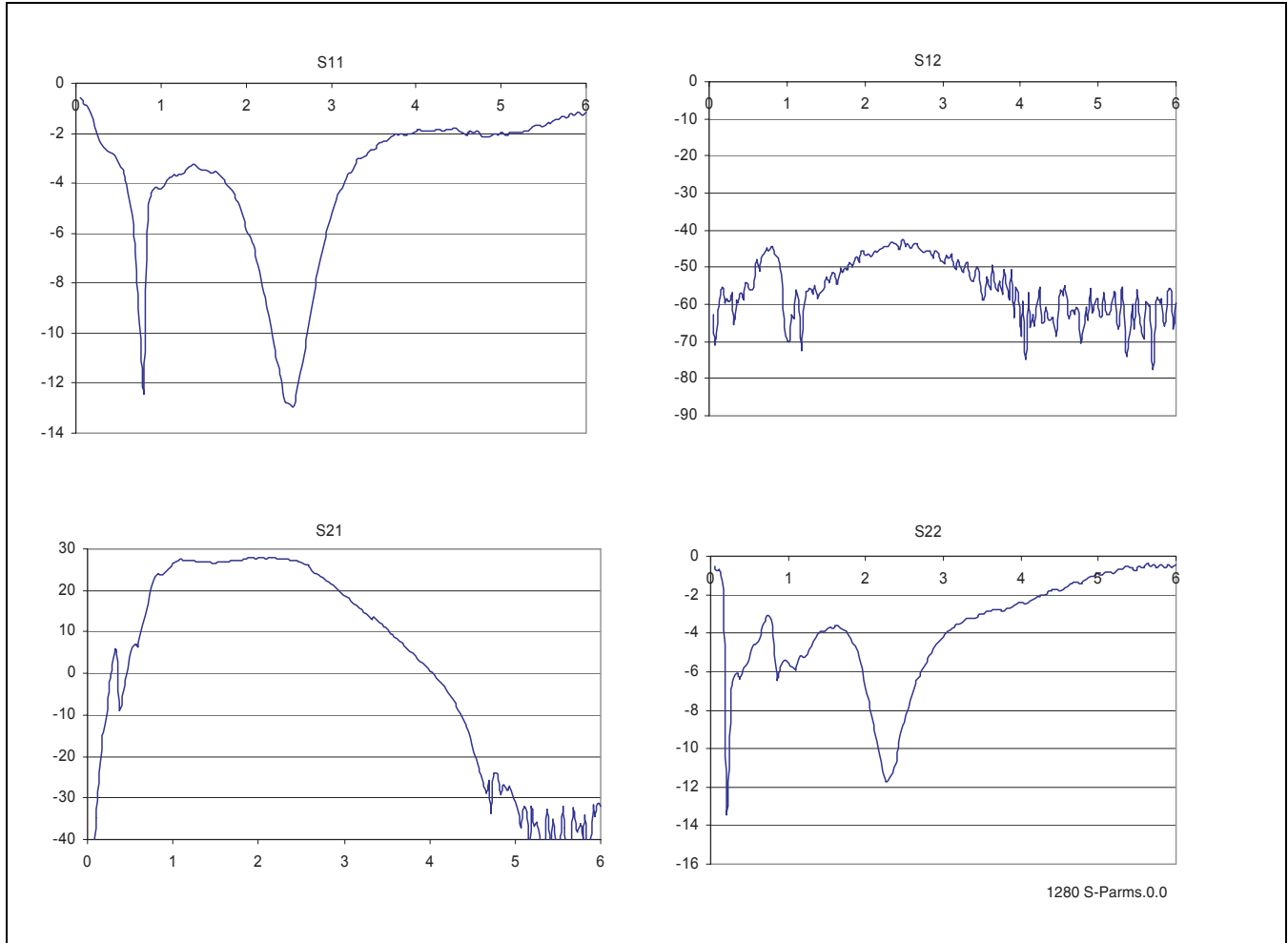

FIGURE 2: S-PARAMETERS

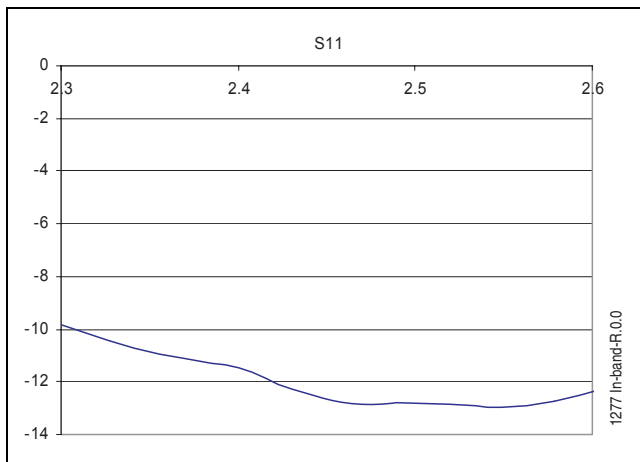

FIGURE 3: IN-BAND RETURN LOSS

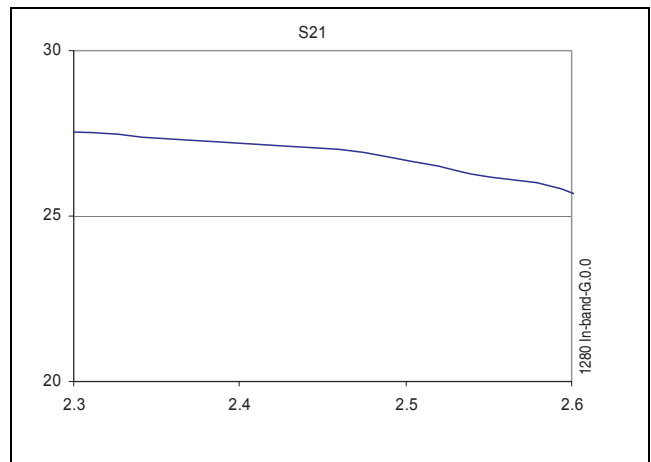

FIGURE 4: IN-BAND GAIN FLATNESS



2.4 GHz High-Linearity Power Amplifier SST12LP10

EOL Data Sheet

TWO-TONE MEASUREMENTS

TEST CONDITIONS: $V_{CC} = 3.3V$, $T_A = 25^\circ C$, $F1 = 2.45 GHz$, $F2 = 2.451 GHz$

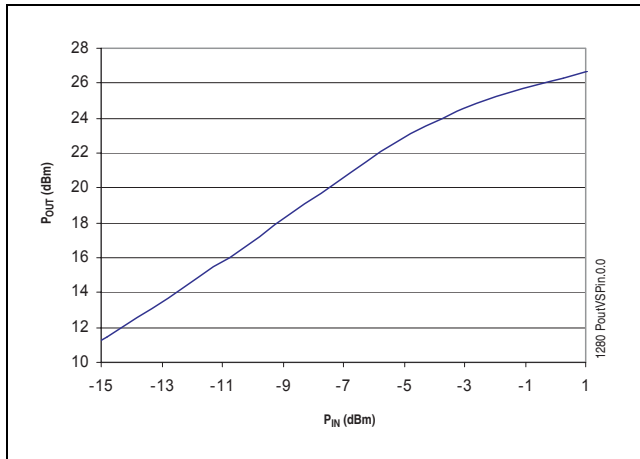

FIGURE 5: RF OUTPUT POWER

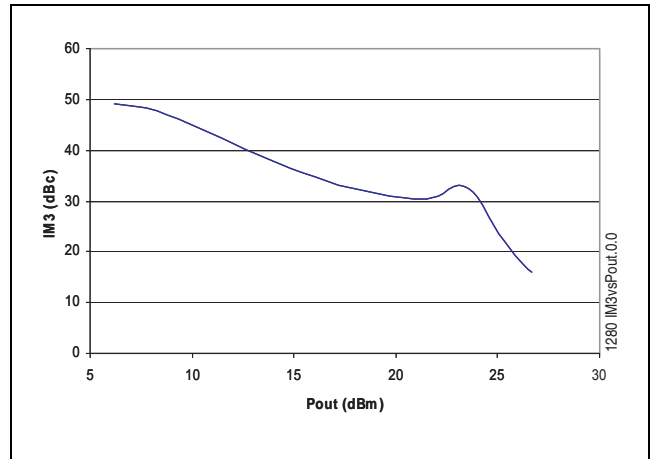

FIGURE 8: IM3 vs POUT

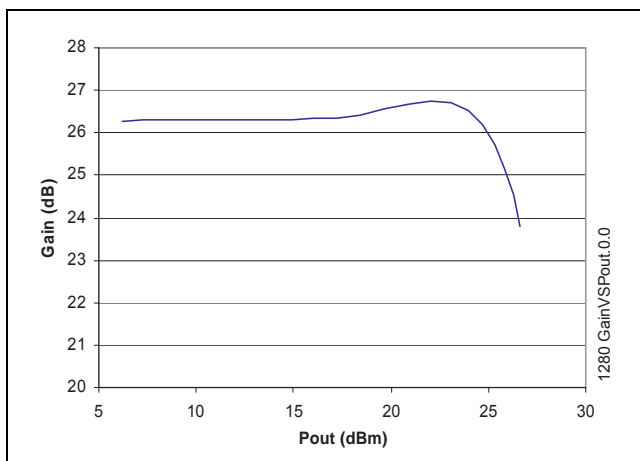

FIGURE 6: GAIN vs POUT

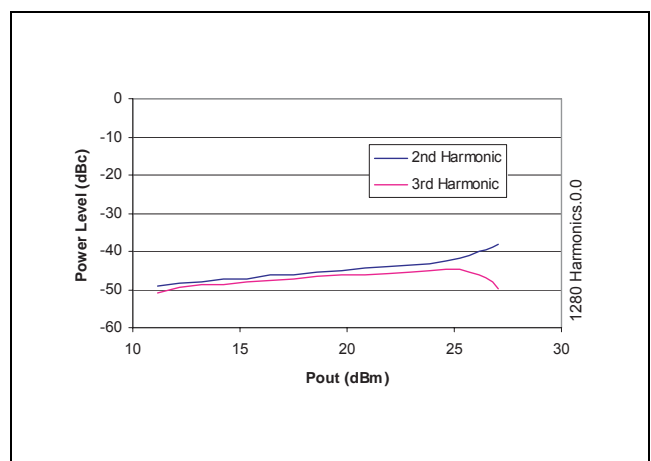

FIGURE 9: HARMONICS

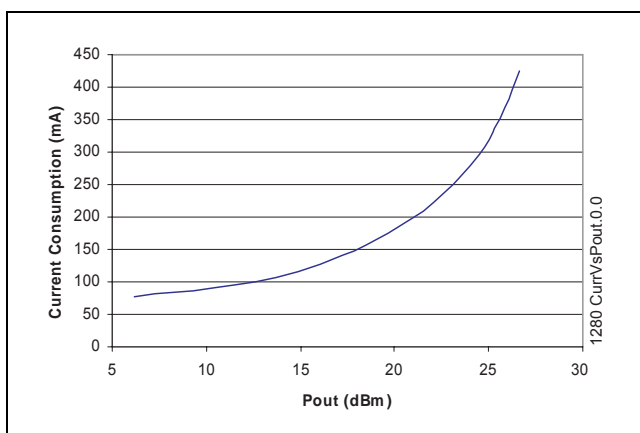

FIGURE 7: ICC vs POUT



2.4 GHz High-Linearity Power Amplifier SST12LP10

EOL Data Sheet

TYPICAL PERFORMANCE CHARACTERISTICS

TEST CONDITIONS: $V_{CC} = 3.3V$, $T_A = 25^\circ C$, $F = 2.45 GHz$ WHEN NOT SPECIFIED

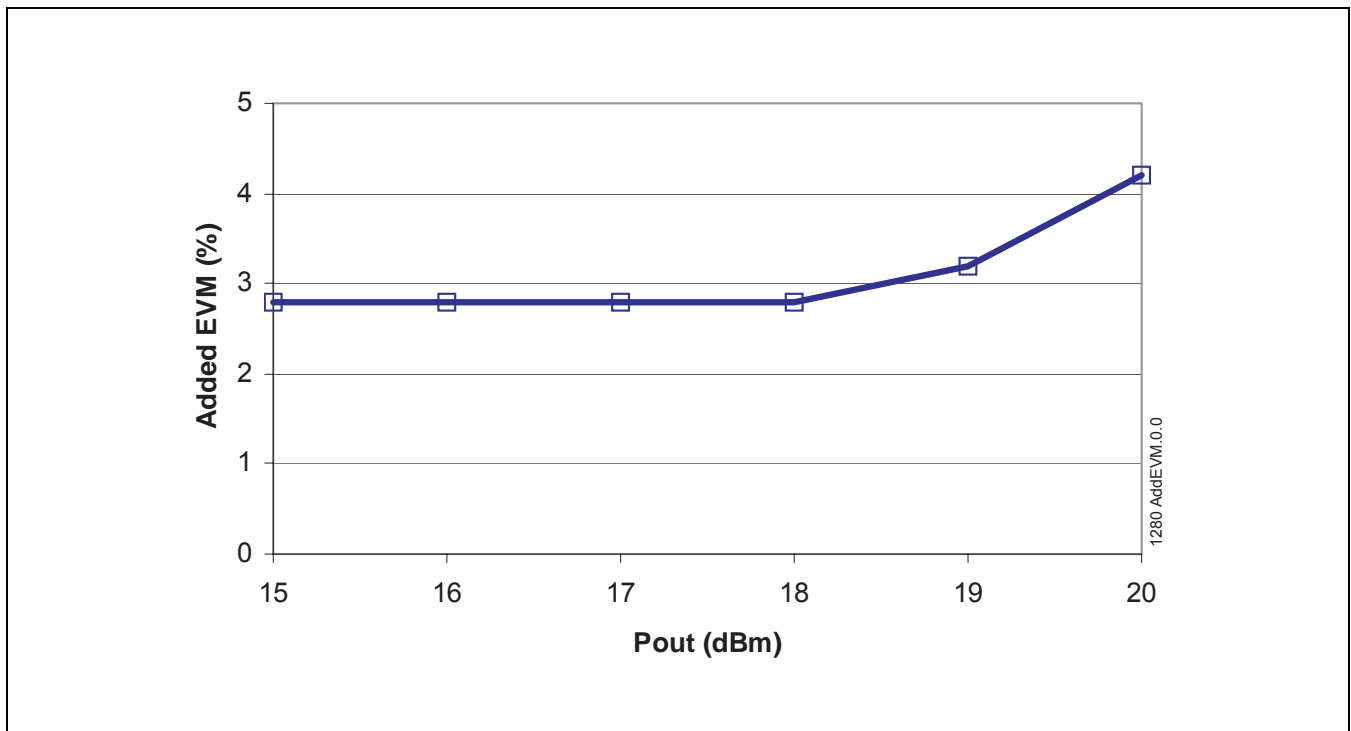
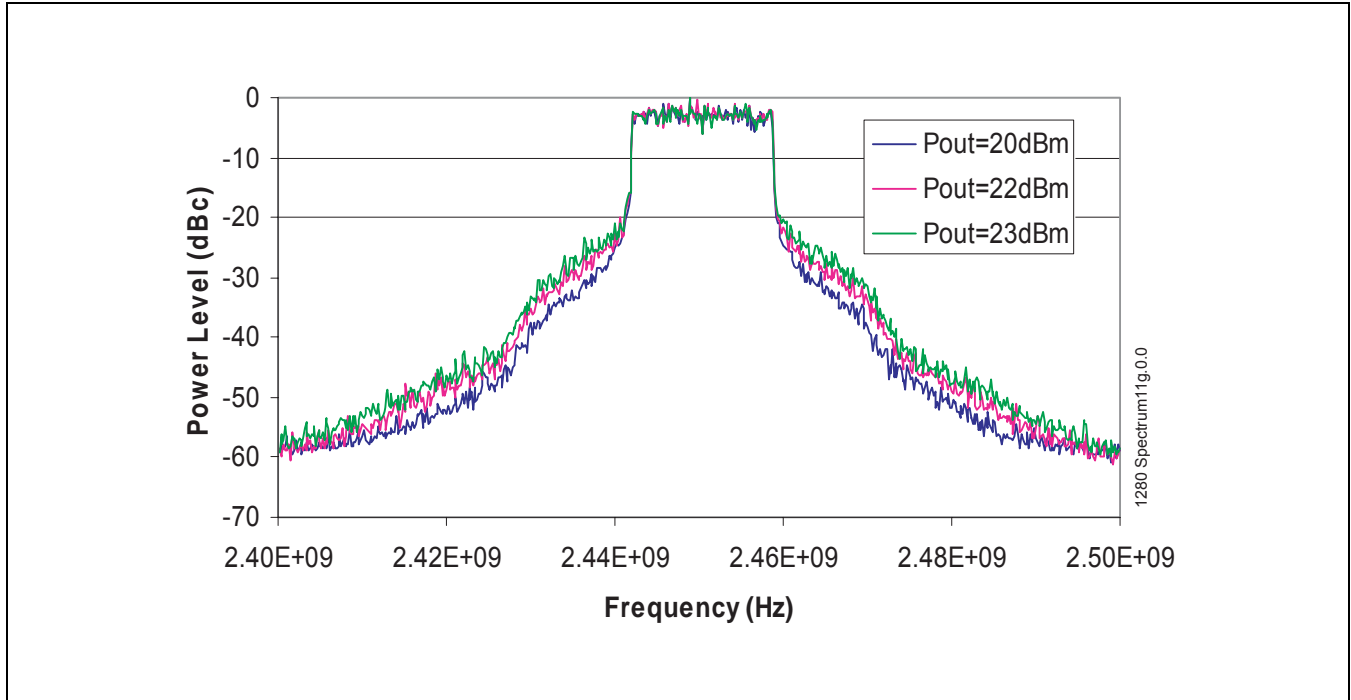

FIGURE 10: 802.11G SPECTRUM AT 20/22/23 DBM, ADDED EVM @ 2.45 GHZ

2.4 GHz High-Linearity Power Amplifier SST12LP10



EOL Data Sheet

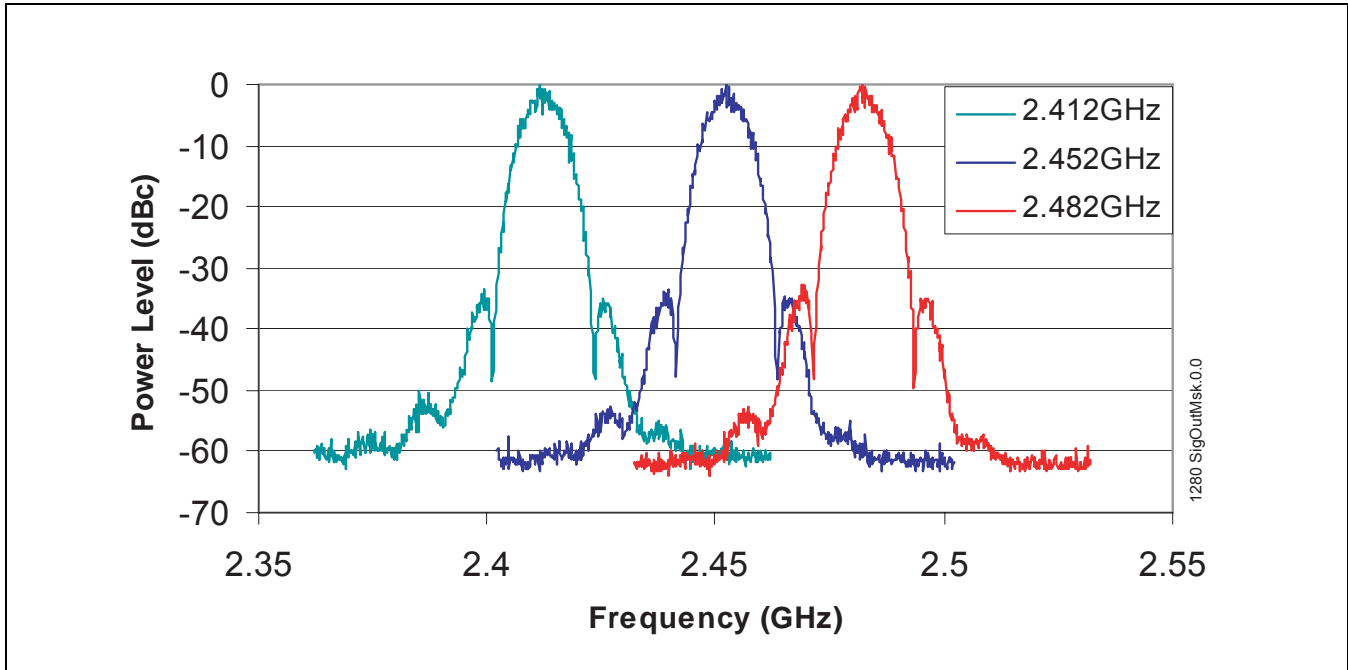

FIGURE 11: 802.11B SIGNAL OUTPUT MASK AT 24 DBM

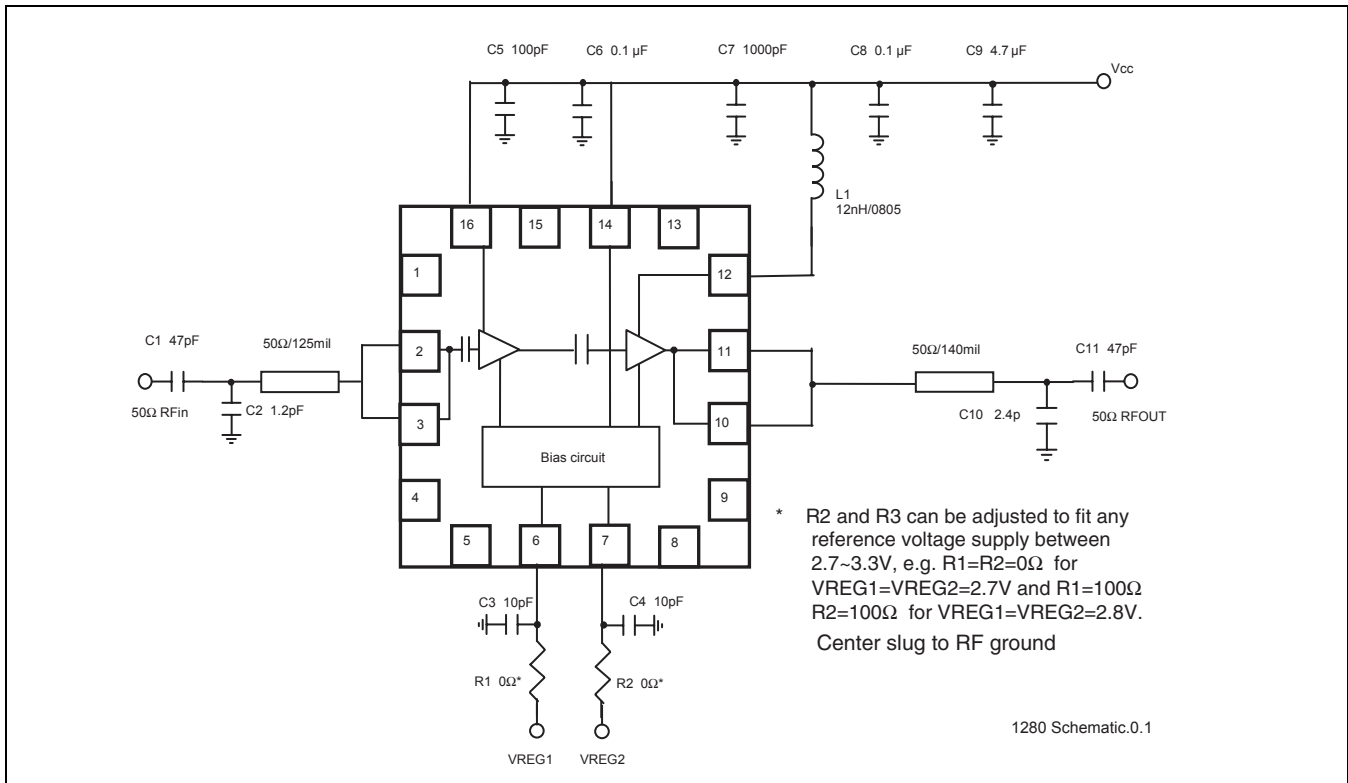

FIGURE 12: TYPICAL SCHEMATIC FOR HIGH-POWER, HIGH-EFFICIENCY 802.11B/G APPLICATIONS



2.4 GHz High-Linearity Power Amplifier SST12LP10

EOL Data Sheet

PRODUCT ORDERING INFORMATION

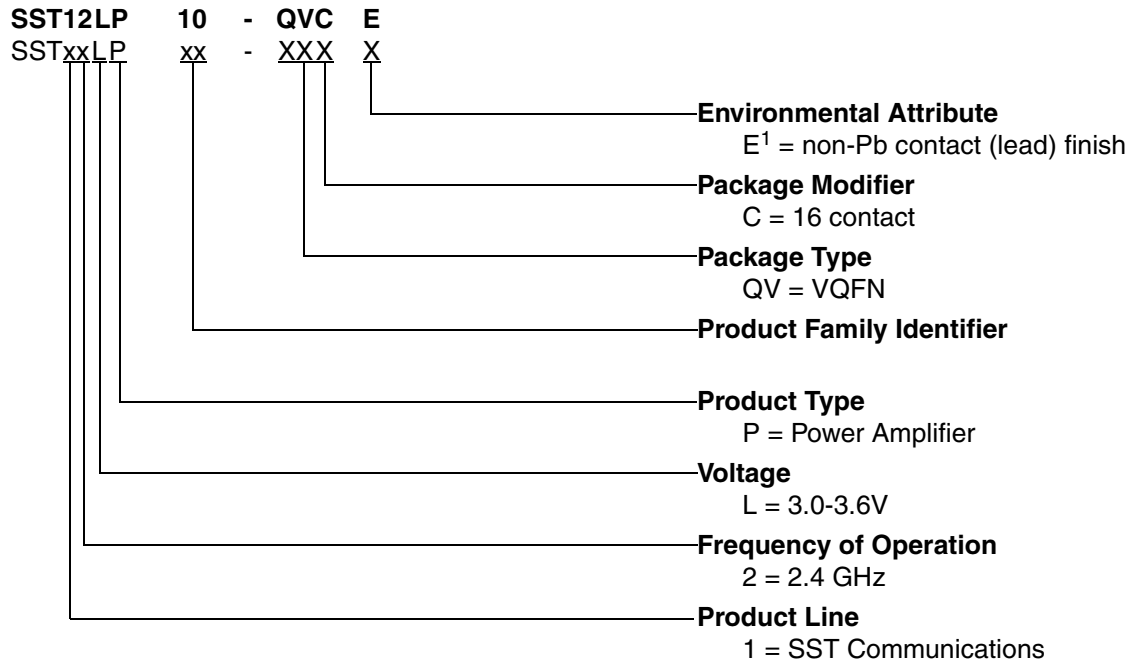

1. Environmental suffix "E" denotes non-Pb solder.
SST non-Pb solder devices are "RoHS Compliant".

Valid combinations for SST12LP10

SST12LP10-QVC
SST12LP10-QVCE

SST12LP10 Evaluation Kits

SST12LP10-QVC-K
SST12LP10-QVCE-K

Note: Valid combinations are those products in mass production or will be in mass production. Consult your SST sales representative to confirm availability of valid combinations and to determine availability of new combinations.

PACKAGING DIAGRAMS

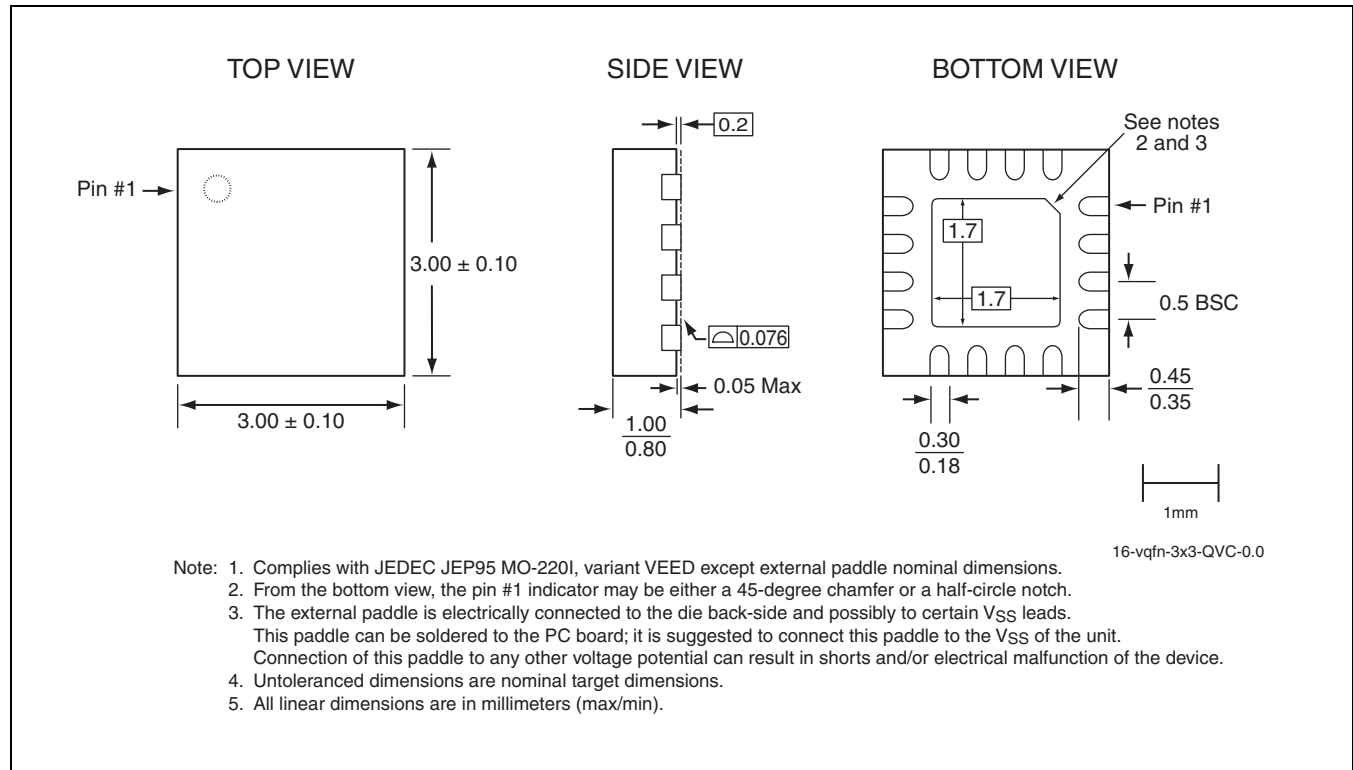

FIGURE 13: 16-CONTACT VERY-THIN QUAD FLAT NO-LEAD (VQFN)
SST PACKAGE CODE: QVC

TABLE 4: Revision History

Revision	Description	Date
00	• S71280: SST conversion of data sheet GP1210	Jan 2005
01	• Updated document status from Preliminary Specification to Data Sheet	Apr 2008
02	• Updated "Contact Information" on page 12.	Feb 2009
03	• End-of-Life data sheet for all devices in S71280	Mar 2009



EOL Data Sheet

CONTACT INFORMATION

Marketing

SST Communications Corp.
5340 Alla Road, Ste. 210
Los Angeles, CA 90066
Tel: 310-577-3600
Fax: 310-577-3605

Sales and Marketing Offices

NORTH AMERICA

Silicon Storage Technology, Inc.
1171 Sonora Court
Sunnyvale, CA 94086-5308
Tel: 408-735-9110
Fax: 408-735-9036

EUROPE

Silicon Storage Technology Ltd.
Mark House
9-11 Queens Road
Hersham, Surrey
KT12 5LU UK
Tel: 44 (0) 1932-238133
Fax: 44 (0) 1932-230567

JAPAN

SST Japan
NOF Tameike Bldg, 9F
1-1-14 Akasaka, Minato-ku
Tokyo, Japan 107-0052
Tel: 81-3-5575-5515
Fax: 81-3-5575-5516

ASIA PACIFIC NORTH

SST Macao
Room N, 6th Floor,
Macao Finance Center, No. 202A-246,
Rua de Pequim, Macau
Tel: 853-2870-6022
Fax: 853-2870-6023

ASIA PACIFIC SOUTH

SST Communications Co.
16F-6, No. 75, Sec.1, Sintai 5th Rd
Sijhih City, Taipei County 22101
Taiwan, R.O.C.
Tel: 886-2-8698-1198
Fax: 886-2-8698-1190

KOREA

SST Korea
6F, Heungkuk Life Insurance Bldg 6-7
Sunae-Dong, Bundang-Gu, Sungnam-Si
Kyungki-Do, Korea, 463-020
Tel: 82-31-715-9138
Fax: 82-31-715-9137