

# **SEMICONDUCTOR PRODUCTS**

**SHORT FORM CATALOG**



**2011**

INTEGRAL JSC reserves the right to make changes in device design, specifications and other information identified in this publication without notice and assumes no responsibility for the use of any device described herein.

INTEGRAL JSC advises its customers to obtain the latest version of relevant information to verify before placing orders, that the information being relied upon is current.

Reference to products of other manufacturers are solely for convenience and do not imply total equivalency of design, performance, or otherwise.

# CONTENTS

Introduction .....	5
Quality .....	6
<b>SEMICONDUCTOR DEVICES FACTORY</b> .....	<b>7</b>
<b>Integrated Circuits</b> .....	<b>8</b>
<b>Memories</b> .....	<b>8</b>
EEPROM with I <sup>2</sup> C Bus .....	8
EEPROM with 3-wire Bus .....	9
EEPROM with SPI Bus .....	9
<b>Microcontrollers, Drivers, Peripherals IC</b> .....	<b>10</b>
Single-Chip Microcontrollers .....	10
Display Driver IC .....	11
LED Driver Circuits .....	11
Interface Integrated Circuits .....	12
Real Time Clock .....	12
<b>TV and Audio IC</b> .....	<b>14</b>
Vision and Sound IF Demodulation IC .....	14
Video Amplifiers .....	14
Vertical Deflection Circuits .....	15
Power Supply IC .....	16
SAW Filters for TV .....	17
ICs for Audio Systems .....	17
<b>Telecommunications IC</b> .....	<b>19</b>
Switches and DTMF Receivers .....	19
Pulse and Tone/Pulse Dialers .....	19
Switching Lines IC .....	20
Single Chip Telephone IC .....	21
Speaker Integrated Circuits .....	21
Tone Telephone Ringers .....	22
IC for Smart Cards .....	23
ICs for Systems of Identification .....	24
<b>Power Electronics, Standard Analog IC</b> .....	<b>25</b>
ICs for Control and Power Electronics .....	25
Automotive .....	26
Sensors .....	27
Timers .....	27
Comparators .....	28
Timers (Reference Data) .....	29
Operational Amplifiers .....	30
$\mu$ p Supervisory Circuits .....	31
Voltage Regulators .....	31
Switching Regulators .....	32
PWM Controllers .....	33
Voltage Regulators (Reference Data) .....	34
<b>Standard Digital Logic IC</b> .....	<b>36</b>
IW4000A Series .....	36
IW4000B series .....	36
IN74ACXXX series .....	38
IN74ACTXXX series .....	39
IN74VHCXXX series .....	40
IN74VHCTXXX series .....	40
IN74HCXXX series .....	41
IN74HCTXXX series .....	42
IN74LVXXX series .....	43
IN74XXX series .....	44
IN74LSXXX series .....	44
N74ALSXXX series .....	44
Functional selection .....	47
Family Characteristics .....	52
<b>Clock/Watch IC</b> .....	<b>55</b>
CMOS IC for LCD Wrist-Watches and Clocks .....	55
Digital watch .....	55
Analog - Digital watch .....	56
Analog watch and clock .....	56
Analog clock .....	56
LED watch .....	56

Watch with Vacuum – Luminescent Display .....	56
<b>Electronic Thermometer IC .....</b>	<b>57</b>
<b>Discrete Semiconductors .....</b>	<b>58</b>
<b>Transistors, Diodes, Diode Arrays .....</b>	<b>58</b>
Power N-Channel MOSFETs .....	58
Fast (Ultrafast) Rectifying Diode (FRD, UFRD).....	59
Photo-diode .....	59
Power Zener Diodes .....	59
Fast (Ultrafast) Rectifying Diode Arrays (FRDA, UFRDA) .....	59
<b>Systems of Information Display .....</b>	<b>60</b>
<b>Foundry-business .....</b>	<b>62</b>
Base Technology Process.....	63
<b>Services.....</b>	<b>69</b>
Mask Making .....	69
Development and Production .....	70
<b>TRANSISTOR .....</b>	<b>71</b>
<b>Discrete Semiconductors.....</b>	<b>72</b>
<b>Transistors .....</b>	<b>72</b>
Bipolar Transistors .....	72
Power Bipolar Darlington Transistors .....	76
Unijunction Transistors .....	76
Low Power N-Channel MOSFETs .....	77
Low Power P-Channel MOSFETs .....	77
Logic Level N-Channel MOSFETs .....	77
Power N-Channel MOSFETs .....	78
Power P-Channel MOSFETs .....	79
<b>Diodes, Diodes Arrays.....</b>	<b>80</b>
Variable Capacitance Diodes .....	80
Switching Diode Arrays .....	80
Variable Capacitance Diode Arrays .....	80
Power Diode Arrays .....	80
Power Schottky Diode .....	81
<b>Thyristors and Triacs .....</b>	<b>82</b>
Power Thyristors and Triacs.....	82
<b>Integrated Circuits .....</b>	<b>83</b>
Voltage Regulators.....	83
Precision Low Voltage Reference .....	84
Voltage Detectors.....	84
Melody IC .....	84
ICs for Television.....	85
<b>TSVETOTRON .....</b>	<b>87</b>
<b>Discrete Semiconductors.....</b>	<b>88</b>
<b>Diodes.....</b>	<b>88</b>
Silicon Epitaxial Planar Switching Diodes .....	88
Zener Diodes .....	88
<b>Package Outlines .....</b>	<b>89</b>
<b>Contacts.....</b>	<b>110</b>

## INTRODUCTION

*«INTEGRAL» JSC develops, manufactures and exports microelectronic components and electronic products. «INTEGRAL» JSC provides a full cycle of design and manufacture: from silicon substrates up to integrated circuits and semiconductor devices, from microelectronic components up to electronic.*

*The structure of «INTEGRAL» JSC affiliates:*

*«SEMICONDUCTOR DEVICES FACTORY» subsidiary of INTEGRAL JSC (city of Minsk)*

*«DC BELMICROSYSTEMS» subsidiary of INTEGRAL JSC (city of Minsk)*

*«TRANSISTOR» subsidiary of INTEGRAL JSC (city of Minsk)*

*«KAMERTON» subsidiary of INTEGRAL JSC (city of Pinsk)*

*«INTEGRAL» JSC has a representative office in China.*

*Total labour is more than 6 thousand persons.*

*Since 2009 Mr. Vitaly A. Solodukha has been the General Director of «INTEGRAL» JSC.*

*The main line of activity of «INTEGRAL» JSC is design and manufacture of microelectronic products - over 70 % of the total production volume - for the branches manufacturing goods of household and consumer electronics.*

*«INTEGRAL» JSC exports more than 70 % of the volume of manufactured goods to the markets of the Russian Federation, Sout - East Asia, India and Western Europe.*

*The goods are exported to 30 countries of the world.*

*In 2010 «INTEGRAL» JSC designed and implemented 153 types of new products: 71 integrated circuits, 55 discrete semiconductor devices, 27 products of electronics.*

*Manufacture of 0,35  $\mu\text{m}$  design rule integrated circuits on  $\text{\O}200$  mm (8 inch) wafers has been set up.*

*The main lines of the development of «INTEGRAL» JSC are as follows: design and implementation of microelectronic components of power electronics, microsensors and optoelectronics.*

*Development of production of finished electronics is to be carried out in the following lines: displays; automotive electronics and electronics and equipment for health application; cashless payment systems, payment terminals, commercial and bank equipment, smart cards, identification and record keeping systems.*

*«INTEGRAL» JSC is open for cooperation both in design and deliveries of products, and in terms of joint realization of long-term investment projects.*

# QUALITY ASSURANCE SYSTEM

*Quality Assurance System of Joint Stock Company «INTEGRAL» has been created 15 years ago. In 1999 it was certified by «KEMA», the International Certification Center, and «BelGISS», The Scientific and Production Republican Unitary Enterprise “Belarusian State Institute for Standardization & Certification” for the conformance to ISO 9001.*

*Basic purpose of Quality Assurance System is integrating efforts of all the employees in order to carry out design, manufacture and sales of high-quality, competitive and easily producible integrated circuits, semiconductor devices, liquid crystal displays and other products matching to the utmost the requirements of the customers and fulfilling their demands.*

*At present Quality Assurance Systems of JSC «INTEGRAL» Affiliates (Research and Production Center «Belmicrosystems», «Semiconductor Devices Factory», «Transistor») are certified for the conformance to ISO 9001-2009 standard in the National System of the Republic of Belarus and to DIN EN ISO 9001:2008 standard of TGA, foreign Certification Organization in Germany, as regards to design and manufacture of integrated circuits, semiconductor devices, liquid crystal displays. Quality Assurance System for single-crystal silicon wafer manufacture of «Kamerton» complies with the requirements of ISO 9001:2001 Standard of Belarus.*



# **SEMICONDUCTOR DEVICES FACTORY**

# INTEGRATED CIRCUITS

## Memories

### • EEPROM with I<sup>2</sup>C Bus

Part	Pin to Pin Compatibility	Density, Bit	Voltage Supply, V	Maximum Bus Speed, kHz	Operating Current Read/Write, mA	Standby Current max, $\mu$ A	Package
IN24AA02AN* (A0,A1,A2 are used) IN24AA02AD* (A0,A1,A2 are used)	24AA02	<b>2K</b> (256x8)	1.8 - 5.5	100/400	1.0/3.0	1	DIP-8 SO-8
IN24AA02BN* IN24AA02BD*	24AA02	<b>2K</b> (256x8)	1.8 - 5.5	100/400	1.0/3.0	1	DIP-8 SO-8
IN24AA08BN* IN24AA08BD*	24AA08B	<b>8K</b> (1024x8)	1.8 - 5.5	100/400	1.0/3.0	100	DIP-8 SO-8
IN24AA32AN IN24AA32AD	24AA32A	<b>32K</b> (4096x8)	1.8 - 5.5	100/400	0.4/3.0	1	DIP-8 SO-8
IN24AA64N* IN24AA64D*	24AA64	<b>64K</b> (8192x8)	1.7-5.5	100/400	1.0/3.0	1	DIP-8 SO-8
IN24LC02BN IN24LC02BD	24LC02B	<b>2K</b> (256x8)	2.5 - 5.5	100/400	1.0/3.0	100	DIP-8 SO-8
IN24LC02N IN24LC02D	24LC02	<b>2K</b> (256x8)	2.5 - 5.5	100/400	1.0/3.0	100	DIP-8 SO-8
IN24LC04BN IN24LC04BD	24LC04B	<b>4K</b> (512x8)	2.5 - 5.5	100/400	1.0/3.0	100	DIP-8 SO-8
IN24LC08BN IN24LC08BD	24LC08B	<b>8K</b> (1024x8)	2.5 - 5.5	100/400	1.0/3.0	100	DIP-8 SO-8
IN24LC16BN IN24LC16BD	24LC16B	<b>16K</b> (2048x8)	2.5 - 5.5	100/400	1.0/3.0	100	DIP-8 SO-8
INA2586N	SDA2586	<b>8K</b> (1024x8)	4.75 - 5.25	100	20	-	DIP-8
INF8582EN-2	PCF8582E	<b>2K</b> (256x8)	4.5 - 5.5	100	1.6/2.5	10	DIP-8
INF8594EN	PCF8594E-2	<b>4K</b> (512x8)	4.5 - 5.5	100	0.2/2.5	10	DIP-8

\* Pilot Production

● **EEPROM with 3-wire Bus**

Part	Pin to Pin Compatibility	Density, Bit	Voltage Supply, V	Maximum Bus Speed, MHz	Operating Current Read/Write, mA	Standby Current max, $\mu$ A	Package
IN93AA46AN IN93AA46AD	93AA46A	<b>1K</b> (128x8)	1.8 - 5.5	1	0.5/3	5	DIP-8 SO-8
IN93AA46BN IN93AA46BD	93AA46B	<b>1K</b> (64x16)	1.8 - 5.5	1	0.5/3	1	DIP-8 SO-8
IN93AA46CN IN93AA46CD	93AA46C	<b>1K</b> (128x8 or 64x16)	1.8 - 5.5	1	0.5/3	5 or 1	DIP-8 SO-8
IN93AA56AN IN93AA56AD	93AA56A	<b>2K</b> (256x8)	1.8 - 5.5	1	0.5/3	5	DIP-8 SO-8
IN93AA56BN IN93AA56BD	93AA56B	<b>2K</b> (128x16)	1.8 - 5.5	1	0.5/3	1	DIP-8 SO-8
IN93AA56CN IN93AA56CD	93AA56C	<b>2K</b> (256x8 or 128x16)	1.8 - 5.5	1	0.5/3	5 or 1	DIP-8 SO-8
IN93AA66AN IN93AA66AD	93AA66A	<b>4K</b> (512x8)	1.8 - 5.5	1	0.5/3	5	DIP-8 SO-8
IN93AA66BN IN93AA66BD	93AA66B	<b>4K</b> (256x16)	1.8 - 5.5	1	0.5/3	1	DIP-8 SO-8
IN93AA66CN IN93AA66CD	93AA66C	<b>4K</b> (512x8 or 256x16)	1.8 - 5.5	1	0.5/3	5 or 1	DIP-8 SO-8
IN93AA86AN IN93AA86AD	93AA86A	<b>16K</b> (2048x8)	1.8 - 5.5	1	0.5/3	5	DIP-8 SO-8
IN93AA86BN IN93AA86BD	93AA86B	<b>16K</b> (1024x16)	1.8 - 5.5	1	0.5/3	1	DIP-8 SO-8
IN93AA86CN IN93AA86CD	93AA86C	<b>16K</b> (2048x8 or 1024x16)	1.8 - 5.5	1	0.5/3	5 or 1	DIP-8 SO-8

● **EEPROM with SPI bus**

Part	Pin to Pin Compatibility	Density, Bit	Clock Frequency, $f_{CLK}$ , MHz, $V_{CC}=4.5-5.5$ V	Supply Current, Read/Write, $I_{CCRD/WR}$ , mA, $V_{CC}=2.5$ V	Standby Current, $I_{CCS}$ , $\mu$ A, $V_{CC}=2.5$ V	Package
IN25AA020N IN25AA020D	25AA020	<b>2K</b> (256x8)	3	0.5/3.0	1	DIP-8 SO-8
IN25AA040N IN25AA040D	25AA040	<b>4K</b> (512x8)	3	0.5/3.0	1	DIP-8 SO-8
IN25AA080N IN25AA080D	25AA080	<b>8K</b> (1024x8)	3	0.5/3.0	1	DIP-8 SO-8
IN25AA160N IN25AA160D	25AA160	<b>16K</b> (2048x8)	3	0.5/3.0	1	DIP-8 SO-8

## •Single-Chip Microcontrollers

Part	Pin to Pin Compat- ibiliti	Internal memory			Max F, MHz	Supply, V	16 bit timer	I/O pins	Interrupt sources	Package
		Data	Program							
		RAM/ EEPROM	ROM	FLASH						
		byte								
IN89C2051DW	89C2051	128 x 8		2Kx8	12	2.7 ÷ 6.0	2	15/15	5	SO-20
IN89C4051DW**	89C4051	128 x 8	-	4Kx8	24	2.7 ÷ 6.0	2	15/15	6	SO-20
IN90S2313DW	90S2313	128 x 8/128 x 8		1Kx16	10	2.7 ÷ 6.0	1(16bit) 1(8bit)	15/15	6	SO-20
IZ7008		40 x 8	1.5K x 8		0.032	1.5 ± 20% 3.0 ± 20%	LCD driver 128 segments			Chip
IZ7010		96 x 4	2K x 12		0.032	1.5 ± 20% 3.0 ± 20%	LCD driver 87 segments			Chip
IZ7012		128 x 8	3Kx16	1Kx16	0.032	2.4 ÷ 5.5	LCD driver 136 segments			Chip
IZ7013		72 x 8	2.5Kx16		0.032	2.4 ÷ 5.5	LCD driver 136 segments			Chip

\*\* Under Development

## • Display Driver IC

Part	Pin to Pin Compatibility	Supply Voltage, Ucc,V	LCD Voltage, V	Duty	RAM	ROM	Column Lines	Common Lines	Frequency, kHz	Pins (Pads)	Notes
					Bit						
<b>LCD Controllers and Drivers</b>											
INF8577CN (LCD direct/duplex driver)	PCF8577CP	2.5...6.0	2.5...6.0	1/1 1/2	2x32		32	2	100	40	I <sup>2</sup> C-bus interface Package:DIP-40
IZ1621 (LCD direct/duplex driver)	HT1621	3...5.0	3-Ucc	1/1 1/2 1/3 1/4	32x4		32	4	256	(48)	Chip
IZ6570AA	NJU6570AA SED1520DAA	2.4...5.5	2.4...13	1/16 1/32	80x32		61	16	2	(100)	Chip
IZ6570OA	NJU6570OA SED1520DOA	2.4...5.5	2.4...13	1/16 1/32	80x32		61	16	18	(100)	Chip
IZ6450	NJU6450A	2.4...5.5	3.5...10	1/16 1/32	80x32		61	16	18	(100)	Chip
IZ6451	NJU6451A	2.4...5.5	3.5...10	1/16 1/32	80x32		72	8	18	(100)	Chip
IZ7065	KS0065	2.7...5.5	3...13	1/8 1/16			40		max400	(59)	Chip
IZ7066	KS0066	4.5...5.5	3...13	1/8 1/11 1/16	80x8		40	16	350	(80)	Chip
IZ602	FL602 HT1621	2.4...5.5	2.4...Ucc	1/2 1/3 1/4	32x4		32	4	256	(48)	Chip
IN472	COP472	2.85...5.5	Ucc	1/3	12x3		12	3	36	20 (20)	DIP-20 Chip

## • LED Driver Circuits

Part	Pin to Pin Compatibility	Function	Package
IL9910N IL9910D IL9910DH IZ9910	HV9910	Universal High Brightness LED Driver, 1A	DIP-8 SO-8 SO-16 Chip
IZ9921	HV9921	20mA/50mA/30mA Switch-Mode LED Driver IC	Chip
IZ9922	HV9922		
IZ9923	HV9923		
IL7150N* IL7150D*	AMC7150	Power LED Driver, 1,5 A	DIP-8 SO-8
IZ1937	LT1937	White LED Step-up Converter	Chip

\* Pilot Production

# INTEGRATED CIRCUITS

## Microcontrollers, Drivers, Peripherals IC

### • Interface Integrated Circuits (Reference Date)

Parameter	IL75232N IL75232DW	IL34C86N IL34C86D	IL34C87N IL34C87D	IN1488N N1488D	IN1489AN IN1489AD	ILX202N ILX202D	ILX207N ILX207DW	ILX208N ILX208D	ILX232N ILX232D	ILX485N ILX485D	ILX3221N	ILX3226N	ILX3232N ILX3232D	ILX3483N	ILX3485N	ILX3486N
ESD Voltage (kV)	0.5	2	2	0.2	0.2	2	2	2	2	4	4	4	4	4	4	4
Power Supply Voltage (V)	±9...±15 for TX 5 for RX	4.5...5.5	4.5...5.5	4.75...5.25	4.75...5.25	4.5...5.5	4.75...5.25	4.5...5.5	4.5...5.5	4.75...5.25	3...5.5	3...5.5	3...5.5	3...3.6	3...3.6	3...3.6
No. of TX/RX	3/5	0/4	4/0	4/0	0/4	2/2	5/3	4/4	2/2	1/1	1/1	1/1	2/2	1/1	1/1	1/1
No. of TX/RX on Bus										32						
Supply Current (mA)	30	22	0.05	20	26	10	20	20	10	0.9	0.001	0.001	1	0.001	0.001	0.001
Standard	RS-232	•		•	•	•	•	•	•		•	•	•			
	RS-485/RS-422									•				•	•	•
	RS-422/RS-423		•	•												
AutoShutdown Plus, AutoShutdown										•	•					
Date Rate (bps)						64K	120K	120K	120K	2.5M	250K	250K	120K	250K	12M	2.5M
External Caps (µF)		4x0.1	4x0.1			4x0.1	4x0.1	4x0.1	4x1.0		4x0.1	4x0.1	4x0.1	-	-	-
Operating Temperature Range (°C)	0 ÷ +75	-40 ÷ +85		-10 ÷ +70							-40 ÷ +85					

### • Real Time Clock

Part	Pin to Pin Compatibility	Function	Package
<b>Digital timers</b>			
IN1307N IN1307D	DS1307N/ZN	64 x 8 Serial Real Time Clock	DIP-8 SO-8
IN1356D	M41T56	512 bit (64 bit x 8) Serial Access Timekeeper SRAM	SO-8
IN1363D	PCF8563	Real Time Clock / Calendar	SO-8
INA8583N	PCF8583P	Clock Calendar with 256x8 Bit Static RAM with I <sup>2</sup> C Bus	DIP-8
IZ1325*	RX8025	Real Time Clock / Calendar with I <sup>2</sup> C Bus	Chip

\* Pilot Production

• **Real Time Clock** (Reference Date)

Parameter		Symbol	IN1307N/D	IN1356D	IN1363D	INA8583N
Supply Voltage, Ucc		V	4.5...5.5	4.5...5.5	1.8...5.5	2.5...6.0
Battery Supply Voltage, VBAT		V	2.0...3.5	2.5...3.5		
Standby Current, Iccs (max)		µA	200	100 (typ)	0.55	50
Active Supply Current, IccA, (max)		µA	1500	300	800	200
Battery Current, IBAT1 (max)		nA	500	550		
Clock Frequency, fscl (max)		kHz	100	100	400	100
Programmable Signal		Hz	1; 4096; 8192; 32768	512	1; 32; 1024; 32768	32; 1024; 32768
Operating Temperature, TA		°C	- 40 ÷ + 85			- 20 ÷ + 70
Functions	clock	seconds	•	•	•	•
		minutes	•	•	•	•
		hours	•	•	•	•
		alarm			•	•
	calendar	weekday	•	•	•	•
		date of the month	•	•	•	•
		month	•	•	•	•
		years	•	•	•	•
		century		•		
	programmable alarm, timer and interrupt function				•	•
	software clock calibration			•		•
	automatic power-fail detect and switch circuitry		•	•		
	interface			I <sup>2</sup> C	I <sup>2</sup> C	I <sup>2</sup> C

# INTEGRATED CIRCUITS

## TV and Audio IC

### • Vision and Sound IF Demodulation IC

Part	Pin to Pin Compatibility	Function	Features	Package
ILA8842NS ILA8844NS	TDA8842 TDA8844	I2C BUS Controlled PAL/NTSC/Secam TV processor	<ul style="list-style-type: none"> <li>□ Vcc=7.2...8.8 V</li> <li>□ Icc=110 mA</li> <li>□ Vision IF circuit with PLL demodulator</li> <li>□ Nigament-free multi-standard FM sound demodulator (4.5 MHz to 6.5 MHz)</li> <li>□ Audio switch</li> <li>□ Flexible source selection with CVBS switch and Y(CVBS)/C input so that a comb filter can be applied</li> <li>□ Vertical count-down circuit</li> <li>□ Low power dissipation 850 mW</li> </ul>	SDIP-56
ILA8362ANS ILA8362BNS ILA8362NS	TDA8362A TDA8362B TDA8362	Multistandard TV Processor	<ul style="list-style-type: none"> <li>□ Vcc=7.2...8.8 V</li> <li>□ Icc ≤ 120 mA</li> <li>□ Multistandard vision IF circuit (positive and negative modulation)</li> <li>□ Multistandard FM sound demodulator (4.5...6.5 MHz)</li> <li>□ PAL/NTSC colour decoder with automatic search system</li> <li>□ RGB control circuit with lines RGB inputs and fast blanking</li> <li>□ Horizontal synchronization with two control loops and alignment free horizontal oscillator</li> <li>□ Vertical count-down circuit and vertical preamplifier</li> <li>□ Low power dissipation 600 mW</li> </ul>	SDIP-52
ILA8890H** ILA8891H**	TDA8890H TDA8891H	TV Processor	<ul style="list-style-type: none"> <li>□ Ucc=5.0 ± 0.3 V</li> <li>□ Icc ≤ 100 mA</li> <li>□ Video signal and sound IF processing</li> <li>□ Line and frame synchronization (for ILA8891H)</li> <li>□ Decoding of signals of color TV systems PAL, NTSC, SECAM (for ILA8891H)</li> <li>□ RGB signal processing</li> <li>□ Delay of signal by one line duration (for ILA8891H)</li> <li>□ Y signal conditioner in output signal PrPb bus for "picture in picture" function (for ILA8891H)</li> <li>□ Separate IF sound input</li> <li>□ Input sound signal switchboard system with seven broadband stereo inputs</li> </ul>	QFP-80

\*\* Under Development

### • Video Amplifiers

Part	Pin to Pin Compatibility	Function	Features	Package
ILA6107Q	TDA6107Q	Triple Video Output Amplifier	<ul style="list-style-type: none"> <li>□ Single supply voltage of 200 V</li> <li>□ Internal reference voltage of 2.5 V</li> <li>□ High slew rate of 900V/μs</li> <li>□ Bandwidth of 5.0MHz typical for output signal of 60 V (peak-to-peak value)</li> </ul>	DBS 9MPF

• **Vertical Deflection Circuits**

Part	Pin to Pin Compatibility	Function	Features	Package
ILA3654 ILA3654Q	TDA3654Q	Vertical Deflection and Guard Circuit (110°)	<ul style="list-style-type: none"> <li>□ V<sub>cc</sub>=20...30 V</li> <li>□ Direct drive to the deflection coils</li> <li>□ 90° and 110° deflection system</li> <li>□ Internal voltage stabilizer</li> </ul>	SIL-9P DBS-9P
ILA8351	TDA8351	Vertical Deflection and Guard Amplifier	<ul style="list-style-type: none"> <li>□ 90° and 110° deflection system with line unrolling frequency from 50 to 120 Hz</li> <li>□ Operated by direct current output cascade of vertical deflection</li> <li>□ Vertical flyback switch</li> <li>□ Output current 1.5 A</li> </ul>	SIL-9P
ILA8356	TDA8356	Vertical Deflection and Guard Amplifier	<ul style="list-style-type: none"> <li>□ 90° and 110° deflection system with line unrolling frequency from 50 to 120 Hz</li> <li>□ Operated by direct current output cascade of vertical deflection</li> <li>□ Vertical flyback switch</li> <li>□ Output current 2.0 A</li> </ul>	SIL-9P
ILA8357 ILA8359	TDA8357 TDA8359	Full bridge vertical deflection output circuit	<ul style="list-style-type: none"> <li>□ 90° and 110° colour deflection system for 25 to 200 Hz field frequency</li> <li>□ 4:3 and 16:9 picture tubes</li> <li>□ Operated by direct current output cascade of vertical deflection</li> <li>□ Vertical flyback switch</li> <li>□ Built in guard circuit</li> <li>□ Thermal protection circuit</li> <li>□ Output current 2.0 A (ILA8357)</li> <li>□ Output current 3.2 A (ILA8359)</li> </ul>	SOT523-1

# INTEGRATED CIRCUITS

## TV and Audio IC

### • Power Supply IC

Part	Pin to Pin Compatibility	Function	Features	Package
ILA8133A	TDA8133A	5.1 V + 8 V Regulator with Disable and Reset	<ul style="list-style-type: none"><li>□ Output currents up to 0.75 A</li><li>□ Fixed precision output 1 voltage 5.1 V±2%</li><li>□ Fixed precision output 2 voltage 8 V±2%</li><li>□ Output 1 with reset facility</li><li>□ Output 2 with disable by TTL input</li><li>□ Short circuit protection at both outputs</li><li>□ Thermal protection</li><li>□ Low drop output voltage</li></ul>	TO-220 AB/7
ILA8138A	TDA8138A	Dual 5.1 V + 12 V Regulator with Disable and Reset	<ul style="list-style-type: none"><li>□ Output currents up to 1 A</li><li>□ Fixed precision output 1 voltage 5.1 V±2%</li><li>□ Fixed precision output 2 voltage 12 V±2%</li><li>□ Output 1 with reset facility</li><li>□ Output 2 with disable by TTL input</li><li>□ Short circuit protection at both outputs</li><li>□ Thermal protection</li><li>□ Low drop output voltage</li></ul>	TO-220 AB/7
IL44608N40 IL44608N75 IL44608N100	MC44608P40 MC44608P75 MC44608P100	SMPS Controller	<ul style="list-style-type: none"><li>□ Integrated Start-Up Source</li><li>□ Lossless Off-Line Start-Up</li><li>□ Direct Off-Line Operation</li><li>□ Fast Start-Up</li><li>□ Flexibility</li><li>□ Duty Cycle Control</li><li>□ Undervoltage Lockout with Hysteresis</li><li>□ On Chip Oscillator Switching Frequency 40, 75, 100 kHz</li><li>□ Secondary Control with Few External Components</li></ul>	DIP-8

● **SAW Filters for TV**

Part	Pin to Pin Compatibility	Function	Features	Package
РБ1ФПА2955	K2955M	SAW IF Filter for Intercarrier Applications	f=38.9 MHz	SIP-5
РБ1ФПА3958 РБ1ФПА9356 РБ1ФПА9650 РБ1ФПА3953	K3958M K9356M K9650M K3953M	IF Filter for Video Application	f=38.9 MHz f=38.9 MHz f=33.90/38.90 MHz f=33.90/38.90 MHz	SIP-5

● **IC for Audio Systems**

Part	Pin to Pin Compatibility	Function	Features	Package
IL34119N IL34119D	MC34119	0.25 W Low Power Mono Audio Amplifier	<ul style="list-style-type: none"> <li>□ Vcc=2...16 V</li> <li>□ Low Quiescent Supply Current for Battery Powered Applications</li> <li>□ Chip Disable Input to Power Down the IC</li> <li>□ Drives a Wide Range of Speaker Loads (8-100 Ω)</li> <li>□ Output Power Exceed 250 mW with 32 Ω Speaker</li> <li>□ Gain Adjustable from 0 dB to 46 dB for Voice Band</li> <li>□ Requires Few External Components</li> </ul>	DIP-8 SO-8
IL386N IL386D	LM386	1 W Low Power Mono Audio Amplifier	<ul style="list-style-type: none"> <li>□ Vcc=4...12 V</li> <li>□ Battery Operation</li> <li>□ Low Quiescent Current Drain: 4 mA</li> <li>□ Voltage Gains from 20 to 200 dB</li> <li>□ Ground Referenced Input</li> <li>□ Self-Centering Output Quiescent Voltage</li> <li>□ Low Distortion</li> </ul>	DIP-8 SO-8
ILA1519B1 ILA1519B1Q	TDA1519B	2 x 6 W Stereo Power Amplifier	<ul style="list-style-type: none"> <li>□ Few external components</li> <li>□ Fixed gain</li> <li>□ Good ripple rejection</li> <li>□ Mute/stand-by switch</li> <li>□ Thermally protected</li> <li>□ Protected against electrostatic discharge</li> </ul>	SIL-9P DBS-9P
ILA2003	TDA2003	10 W Audio Amplifier	<ul style="list-style-type: none"> <li>□ Vcc=8...18 V</li> <li>□ Low number of external components</li> <li>□ High peak output current (up to 3.5 A)</li> <li>□ DC and AC short protection circuit</li> </ul>	P-TO-220-5-11
ILA7056	TDA7056	3 W BTL Mono Audio Output Amplifier	<ul style="list-style-type: none"> <li>□ Vcc=3...18 V</li> <li>□ DC volume control</li> <li>□ Few external components</li> <li>□ Mute mode</li> <li>□ Thermal protection</li> <li>□ Short-circuit proof</li> <li>□ Low power consumption</li> </ul>	SIL-9MPF
ILA7056B	TDA7056B	5 W Mono BTL Audio Amplifier with DC Volume Control	<ul style="list-style-type: none"> <li>□ Vcc=4.5...18 V</li> <li>□ DC volume control</li> <li>□ Few external components</li> <li>□ Mute mode</li> <li>□ Thermal protection</li> <li>□ Short-circuit proof</li> <li>□ No switch-on and of clicks</li> <li>□ Low HF radiation</li> <li>□ Low power consumption</li> </ul>	SIL-9MPF
ILA7496Q	TDA7496Q	2 x 5 W Stereo Power Amplifier with linear volume adjustment	<ul style="list-style-type: none"> <li>□ Vcc=11...35 V</li> <li>□ DC volume control</li> <li>□ Few external components</li> </ul>	SIL-15P

# INTEGRATED CIRCUITS

## TV and Audio IC

### • IC for Audio Systems (continued)

Part	Pin to Pin Compatibility	Function	Features	Package
ILA1308D	TDA1308T	2 x 0.030 W Class AB Stereo Audio Amplifier	<ul style="list-style-type: none"> <li>□ Vcc=3.0...7.0 V</li> <li>□ Wide temperature range</li> <li>□ Excellent power supply ripple rejection</li> <li>□ Low power consumption</li> <li>□ Short-circuit resistant</li> <li>□ High performance                             <ul style="list-style-type: none"> <li>- high signal-to-noise ratio</li> <li>- high slew rate</li> <li>- low distortion</li> </ul> </li> <li>□ Large output voltage swing</li> </ul>	SO-8
ILA8933**	TDA8933T	2x10 W Stereo 20 W Mono Class D Audio Amplifier	<ul style="list-style-type: none"> <li>□ Vcc=10.0...36.0V (assymm.)</li> <li>□ Vcc=±5.0... ±18.0V (symm.)</li> <li>□ Thermal protection</li> <li>□ Short Circuit resistant</li> <li>□ High performance                             <ul style="list-style-type: none"> <li>-high signal-to-noise ratio</li> <li>-high slew rate</li> <li>-low distortion</li> </ul> </li> </ul>	SO-32

\*\* Under Development

### • IC for Audio Systems (Reference Data)

IC's Class	Part	Pin to Pin Compatibility	Supply Voltage, V	Maximum Power, W	Gain, dB	Load resistance, Ω	Package
Low Power	IL34119N, D Mono	MC34119	2.0...16.0	0.25	80	8; 16; 32	DIP-8, SO-8
	IL386N, D Mono	LM386	4.0...12.0	1.0	26...42	8.0 (4.0; 16)	DIP-8, SO-8
	ILA7050N Mono/Stereo BTL	TDA7050	1.6...6.0	1 x 0.140 2 x 0.075	32 (mono) 26 (stereo)	32 (16; 64)	DIP-8
	ILA7052N Mono	TDA7052	3.0...18.0	1.2	38...40	8.0	DIP-8
	ILA7053N Stereo BTL	TDA7053	3.0...18.0	2 x 1.0	38...40	8.0 (16; 25)	DIP-16
	ILA1308T Class AB, Stereo	TDA1308T	3.0...7.0	2 x 0.030	70	8;16; 32; 5K	SO-8
Middle Power	ILA7056 Mono	TDA7056	3.0...18.0	3	39...42	16.0	SIL-9MPF
	ILA7056B Mono with DC Control	TDA7056B	4.5...18.0	5.0	39.5...41.5	16.0	SIL-9MPF
Large Power	ILA1519B1,B1Q Mono/Stereo	TDA1519B	6.0...18.0	12 (mono) 2 x 6 (stereo)	45...47 (mono) 39...41 (stereo)	4.0 8.0	SIL-9P DBS-9P
	ILA2003 Mono	TDA2003	8.0...18.0	10	39.3...40.3	2.0; 4.0	P-TO-220-5-11
	ILA7496Q Stereo with Linear Volume Adjustment	TDA7496Q	10.0...32.0	2x5	28.5...31.5	8.0	SIL-15P
	ILA8933** Class D, Mono/Stereo	TDA8933T	10.0...36.0 (assymm.) ±5.0... ±18.0 (symm.)	20 (mono) 2x10 (stereo)	29.0...31.0	8.0 (16.0)	SO-32

\*\* Under Development

## • Switches and DTMF Receivers

Part	Pin to Pin Compatibility	Function	Features	Package
K561KП6	KT8592	4x4 Crosspoint Switch with Control Memory	<ul style="list-style-type: none"> <li>□ Vcc=5.0...15.0 V</li> <li>□ Icc max=20 mA (Vcc=15.0 V)</li> <li>□ Low of resistance (Typ: 75 Ω at Vcc=12 V)</li> <li>□ Internal control latches</li> <li>□ 2Vcc analog signal capability</li> </ul>	DIP-16
IL9170N IL9170DW	HM9170	DTMF Receiver	<ul style="list-style-type: none"> <li>□ Vcc=2.5...5.5 V</li> <li>□ Icc max=9.0 mA</li> <li>□ Power consumption 15 mW</li> <li>□ Quartz generator 3.58 MHz</li> <li>□ Decoding of 16 DTMF tones-pairs</li> <li>□ 4-bit parallel output</li> <li>□ PWDN</li> </ul>	DIP-18 SO-18
IL567N IL567D	LM567	Tone Decoder	<ul style="list-style-type: none"> <li>□ 20 to 1 frequency range with an external resistor</li> <li>□ Logic compatible output with 100 mA current sinking capability</li> <li>□ Bandwidth adjustable from 0 to 14%</li> <li>□ High rejection of out of band signals and noise</li> <li>□ Immunity to false signals</li> <li>□ Highly stable center frequency</li> <li>□ Center frequency adjustable from 0.01 Hz to 500 kHz</li> </ul>	DIP-8 SO-8
IL9200N IL9200D	HM9200	DTMF generators	<ul style="list-style-type: none"> <li>□ Vcc=2.5...5.5 V</li> <li>□ Low standby current</li> <li>□ Low total distortion 3.58 MHz crystal or ceramic resonator</li> </ul>	DIP-8 SO-8

## • Pulse and Tone/Pulse Dialers

Part	Pin to Pin Compatibility	Function	Features	Package
IL5851N	KS5851	Pulse Dialer with Redial	<ul style="list-style-type: none"> <li>□ Vcc=2.0...6.0 V</li> <li>□ Icc max=150 μA</li> <li>□ Generator frequency 2.4 kHz</li> <li>□ Output frequency 10/20 Hz</li> <li>□ 32-digit redial memory (31 digits in tone mode)</li> <li>□ Selectable Make/Break ratio</li> <li>□ Inter digital pause 800 ms</li> </ul>	DIP-18
IL9151-3N	UM9151-3	Pulse Dialer	<ul style="list-style-type: none"> <li>□ Vcc=2.0...5.5 V</li> <li>□ Direct telephone line operation</li> <li>□ 4x3 matrix keyboard interface</li> <li>□ 22-digit redial memory</li> <li>□ Selectable Make/Break ratio</li> <li>□ Inter digital Pause 800 ms</li> <li>□ High speed test capacity</li> </ul>	DIP-16
IL91531N	UM91531	Parallel Input Tone/Pulse Dialer	<ul style="list-style-type: none"> <li>□ Vcc=2.5...5.5 V</li> <li>□ Quartz generator 3.58 MHz</li> <li>□ Output signal: pulse 10 Hz or DTMF</li> <li>□ 4-bit parallel data input from microcomputer</li> <li>□ Selectable Make/Break ratio</li> <li>□ Inter digital pause 800 ms</li> </ul>	DIP-16

● **Pulse and Tone/Pulse Dialers** (continued)

Part	Pin to Pin Compatibility	Function	Features	Package
IL91214AN IL91214AD IL91214BN IL91214BDW	UMS91214A  UMS91214B	Tone/Pulse Dialer with Handfree Control and Flash Function	<ul style="list-style-type: none"> <li>□ Vcc=2.0...5.5 V</li> <li>□ Quartz generator 3.58 MHz</li> <li>□ 32-digit redial memory</li> <li>□ Tone/Pulse switchable</li> <li>□ Output signal: pulse 10 Hz(20Hz) or DTMF</li> <li>□ Flash Function</li> <li>□ 4x4 keyboard</li> <li>□ 09 - mode output pin (IL91214BN/BDW)</li> <li>□ 10 – key in tone output (IL91214BN/BDW)</li> </ul>	DIP-16 SO-16 DIP-18 SO-18

● **Switching Lines IC**

Part	Pin to Pin Compatibility	Function	Features	Package
IL145567N IL145567DW	MC145567	PCM Codec with Filter	<ul style="list-style-type: none"> <li>□ Fully Differential Analog Circuit Design for Lowest Noise</li> <li>□ Performance Specified for Extended Temperature Range of -40 to +85°C</li> <li>□ Transmit Band- Pass and Receive Low-Pass Filters On-Chip</li> <li>□ Active R-C Pre-Filtering and Post- Filtering</li> <li>□ On-Chip Precision Voltage Reference (2.5 V)</li> <li>□ Typical Power Dissipation of 40 mW, power Down of 1.0 mW at ±5 V</li> <li>□ Push-Pull Power Drivers with External Gain Adjust</li> <li>□ Analog Loopback</li> </ul>	DIP-20 SO-20
IL145557DW	MC145557	PCM Codec with Filter	<ul style="list-style-type: none"> <li>□ Fully Differential Analog Circuit Design for Lowest Noise</li> <li>□ Performance Specified for Extended Temperature Range of -40 to +85°C</li> <li>□ Transmit Band- Pass and Receive Low-Pass Filters On-Chip</li> <li>□ Active R-C Pre-Filtering and Post- Filtering</li> <li>□ On-Chip Precision Voltage Reference (2.5 V)</li> <li>□ Typical Power Dissipation of 40 mW, power Down of 1.0 mW at ±5 V</li> </ul>	SO-16
ILF3866N	TFF3866	Subscriber Line Interface Circuit (SLIC)	<ul style="list-style-type: none"> <li>□ Vcc=-5 V; +5 V</li> <li>□ I<sub>RINBRLY</sub>=30 mA</li> <li>□ Battery feed characteristics programmable via external resistor</li> <li>□ Feed characteristics independent of supply voltage variations</li> <li>□ Integrated ring relay driver</li> <li>□ Internal ring relay disconnection for ring trip</li> <li>□ Loop current, ground key and ring trip detection functions</li> <li>□ Programmable detector threshold of loop current</li> <li>□ Hybrid function in connection with CODEC / FILTER</li> <li>□ Programmable line terminating impedance, complex or real</li> <li>□ On hook transmission</li> <li>□ High longitudinal balance specification</li> <li>□ Tip - ring open circuit state for subscriber loop power denial</li> </ul>	DIP-22

## • Single Chip Telephone IC

Part	Pin to Pin Compatibility	Function	Features	Package
IL2533N IL2533DW	AS2533	Multi-Standard CMOS Single Chip Telephone IC with Dual Soft Clipping	<ul style="list-style-type: none"> <li>□ Line/speech circuit, LD/MF repertory dialler and tone ringer on one 28 pin CMOS chip</li> <li>□ Operating range from 13 to 100 mA (down to 5mA with reduced performance)</li> <li>□ Soft clipping to avoid harsh distortion</li> <li>□ Volume control of receive signal</li> <li>□ Line loss compensation selectable by pin option</li> <li>□ Low noise (max. - 72 dBmp)</li> <li>□ Real or complex impedance</li> <li>□ NET 4 compatible.</li> <li>□ LD/MF switchable dialling</li> <li>□ Pacifier tone during programming</li> <li>□ 31 digit last number redial</li> <li>□ Sliding cursor protocol with comparison</li> <li>□ Pause key for access pause or wait function</li> <li>□ 3 flash keys, 100 ms, 280 ms and 375/600 ms</li> <li>□ On chip MF filter (CEPT CS 203 compatible)</li> <li>□ Ring frequency discrimination</li> <li>□ 3-tone melody generator</li> <li>□ Oscillator Frequency (Resonator: Murata CSA 3.58MG312AM)-3.58 MHz</li> <li>□ 4x4...4x8 Keyboard</li> </ul>	DIP-28 SO-28

## • Speaker Integrated Circuits

Part	Pin to Pin Compatibility	Function	Features	Package
IL34118N IL34118DW	MC34118	Voice Switched Speakerphone Circuit	<ul style="list-style-type: none"> <li>□ <math>V_{cc}=3.0...6.5</math> V</li> <li>□ <math>I_{cc}=5.0</math> mA</li> <li>□ Improved Attenuator Gain Range: 52 dB Between Transmit and Receive</li> <li>□ Low Voltage Operation for Line-Powered Applications (3.0-6.5 V)</li> <li>□ 4-Point Signal Sensing for Improved Sensitivity</li> <li>□ Background Noise Monitors for Both Transmit and Receive Paths</li> <li>□ Microphone Amplifier Gain Set by External Resistors – Mute Function Included</li> <li>□ Chip Disable for Active/Standby Operation</li> <li>□ On Board Filter Pinned-Out for User Defined Function</li> <li>□ Dial Tone Detector to Inhibit Receive Idle Mode During Dial Tone Presence</li> <li>□ Standard 28-Pin Plastic Dip Package and SOIC Package Available</li> <li>□ Compatible with IL34119 Speaker Amplifier</li> </ul>	DIP-28 SO-28
IL34119N IL34119D	MC34119	Telephone Audio Amplifier	<ul style="list-style-type: none"> <li>□ <math>V_{cc}=2.0...16.0</math> V</li> <li>□ <math>I_{cc}=2.7</math> mA</li> <li>□ Drives a wide range of speaker loads (8...100 <math>\Omega</math>)</li> <li>□ Output power exceeds 250 mW with 32 <math>\Omega</math> Speaker</li> <li>□ Low total harmonic distortion</li> <li>□ Gain adjustable 0...46 dB for voice band</li> <li>□ Requires few external components</li> </ul>	DIP-8 SO-8

• **Speaker Integrated Circuits** (continued)

Part	Pin to Pin Compatibility	Function	Features	Package
IL3726/18N IL3726/18DW	PBL3726/18	Speaker Integrated Circuit	<ul style="list-style-type: none"> <li>□ <math>V_{LN}=3.3...4.1</math> V (<math>I_L=15</math> mA)</li> <li>□ <math>V_{LN}=11.0... 15.0</math> V (<math>I_L=100</math>mA)</li> <li>□ 7 Capacitors &amp; Resistors</li> <li>□ Low Voltage Operating</li> <li>□ DTMF signal input with confidence tone</li> <li>□ Mute input for DTMF dialing</li> <li>□ Line loss compensation (line current dependent) for microphone and earpiece amplifiers</li> <li>□ Gain control curve adaptable to exchange supply</li> <li>□ DC line voltage adjustment facility</li> </ul>	DIP-18 SO-20 SO-18
ILA1062AN ILA1062AD ILA1062N ILA1062D	TEA1062A  TEA1062	Low Voltage Transmission Circuit with Dialer Interface	<ul style="list-style-type: none"> <li>□ Low DC line voltage; operates down to 1.6 V</li> <li>□ Line operation current range 10...140 mA</li> <li>□ <math>I_{CC} \leq 1.35</math> mA</li> <li>□ Voltage gain range: <ul style="list-style-type: none"> <li>microphone amplifier 11...52 dB</li> <li>telephone amplifier 20...31 dB</li> </ul> </li> <li>□ Voltage regulator with adjustable static resistance</li> <li>□ Provides supply for external circuits</li> <li>□ Symmetrical high-impedance inputs</li> <li>□ (64 k<math>\Omega</math>) for dynamic, magnetic or piezoelectric microphones</li> <li>□ Asymmetrical high-impedance inputs (32 k<math>\Omega</math>) for electret microphones</li> <li>□ DTMF signal input with confidence tone</li> <li>□ Mute input for pulse or DTMF dialing</li> <li>□ Receiving amplifier for dynamic, magnetic or piezoelectric earpieces</li> <li>□ Large gain setting range on microphone and earpiece amplifiers</li> </ul>	DIP-16 SO-16 DIP-16 SO-16

• **Tone Telephone Ringers**

Part	Pin to Pin Compatibility	Function	Features	Package
IL2410N IL2411N IL2410D IL2411D	KA2410 KA2411 KA2410 KA2411	Two-Tone Telephone Ringer	<ul style="list-style-type: none"> <li>□ <math>V_{CC}=13...29</math> V</li> <li>□ <math>I_{CC}=1.4...4.2</math> mA</li> <li>□ Activation voltage 17...21 V</li> <li>□ Sustaining voltage 9.7...12 V</li> <li>□ Adjusted 2-frequency tone</li> <li>□ Built-in hysteresis prevents false triggering and rotary dial "Chirps"</li> <li>□ External Triggering or Ringer Disable</li> </ul>	DIP-8  SO-8
IL2418N IL2418D	KA2418	Two-Tone Telephone Ringer with Diode Bridge	<ul style="list-style-type: none"> <li>□ <math>V_{CC}=26</math> V</li> <li>□ <math>I_{CC} \text{ max}=1.8</math> mA</li> <li>□ Activation voltage 12.2...13 V</li> <li>□ Sustaining voltage 8.0...8.8 V</li> <li>□ Internal Zener diodes to protect against over voltages</li> <li>□ High noise immunity due to built-in voltage-current hysteresis</li> <li>□ Ringer impedance adjustable with external components</li> <li>□ Output <math>F_1=2100...2550</math> Hz <math>F_2=1500...1850</math> Hz</li> </ul>	DIP-8 SO-8

• **IC for Smart Cards**

Part	Pin to Pin Compatibility	Function	Features	Pads
IZE4406C	SLE4406C	IC for Prepaid Cards	<ul style="list-style-type: none"> <li>□ Vcc=4.5...5.5 V</li> <li>□ 104x1 bit organization</li> <li>□ 3 memory areas with special characteristics (ROM, PROM, EEPROM)</li> <li>□ Maximum of 20480 count units</li> <li>□ Special security features</li> <li>□ Minimum of 100000 write/erase cycles</li> <li>□ Data retention for minimum of 10 years</li> <li>□ Contact configuration and serial interface in accordance to ISO standard 7816-3</li> </ul>	5
IZE4428	SLE4428	Intelligent 1024 byte EEPROM with write protect function & security logic	<ul style="list-style-type: none"> <li>□ EEPROM 1024 byte</li> <li>□ Security code (working as transport code during delivery)</li> <li>□ Byte protection</li> <li>□ Write/ Erase time (min)2.5 ms</li> <li>□ Supply Voltage, 5V</li> <li>□ Ambient temperature, 0 ... + 70°C</li> <li>□ Retention time, 5years</li> <li>□ Health insurance card</li> <li>□ Access control</li> <li>□ Electronic tickets</li> </ul>	5
IZE4442	SLE4442	Intelligent 256 byte EEPROM with write protect function & security logic	<ul style="list-style-type: none"> <li>□ EEPROM 256 byte</li> <li>□ Security code (working as transport code during delivery)</li> <li>□ Byte protection</li> <li>□ Write/ Erase time (min) 2.5 ms</li> <li>□ Supply Voltage, 5V</li> <li>□ Ambient temperature, 0 ... + 70°C</li> <li>□ Retention time, 5 years</li> <li>□ Health insurance card</li> <li>□ Access control</li> <li>□ Electronic tickets</li> </ul>	5
IZ2814	MC2814	IC for Prepaid Cards	<ul style="list-style-type: none"> <li>□ Internally Organized Memory 256 x 8</li> <li>□ Two-wire Serial Interface</li> <li>□ Bidirectional Data Transfer Protocol</li> <li>□ Byte Write Modes</li> <li>□ 8-byte Page Write Modes</li> <li>□ Write Protection Memory</li> <li>□ Self-timed Write/Erase Cycle (20 ms max)</li> <li>□ Endurance: 100000 Cycles</li> <li>□ Data Retention: 10 years</li> <li>□ On-chip Charge Pump for Programming</li> <li>□ Answer to Reset</li> <li>□ Operation Range from -40°C to +70°C</li> </ul>	5
IZ2814A		IC for Prepaid Cards	<ul style="list-style-type: none"> <li>□ Internally Organized Memory 64 x 8</li> <li>□ Two-wire Serial Interface</li> <li>□ Bidirectional Data Transfer Protocol</li> <li>□ Byte Write Modes</li> <li>□ 2-byte Page Write Modes</li> <li>□ Write Protection Memory</li> <li>□ Self-timed Write/Erase Cycle (20 ms max)</li> <li>□ Endurance: 100000 Cycles</li> <li>□ Data Retention: 10 years</li> <li>□ On-chip Charge Pump for Programming</li> <li>□ Answer to Reset</li> <li>□ Operation Range from -40°C to +70°C</li> </ul>	5

# INTEGRATED CIRCUITS

## Telecommunications IC

### • IC for Smart Cards (continued)

Part	Pin to Pin Compatibility	Function	Features	Pads
IZ2815A-03	SLE4436E	IC for Prepaid Cards	<ul style="list-style-type: none"> <li>□ Vcc=4.5...5.5 V</li> <li>□ Icc=5 mA</li> <li>□ 221-bit EEPROM and 16 bit mask-programmable ROM</li> <li>□ 104 bit user memory fully compatible with IZ4406:               <ul style="list-style-type: none"> <li>- 64 bit identification area</li> <li>- 40 bit counter area including 1 bit for personalization</li> </ul> </li> <li>□ 133 bit additional memory for advanced features               <ul style="list-style-type: none"> <li>- 4 bit counter backup (anti-tearing flags)</li> <li>- 1 bit initiation flag for authentication key 2</li> <li>- 16 bit data area 1 for free user access</li> <li>- 48 bit authentication key 1</li> <li>- either 64 bit data area 1 for user defined data or 48 bit authentication key 2</li> </ul> </li> <li>□ EEPROM programming time 5 ms</li> <li>□ Endurance minimum of 100000 write/erase cycles per bit</li> <li>□ Data retention for minimum of 10 years</li> <li>□ Contact configuration and serial interface in accordance to ISO standard 7816-3</li> </ul>	5

### • IC for Systems of Identification

Part	Pin to Pin Compatibility	Function	Features	Pads
IZ2802A	H4102, H4100	Read Only Contactless Identification Device	<ul style="list-style-type: none"> <li>□ fcoil = 100...150 kHz</li> <li>□ Cres = 490 pF</li> <li>□ ROM 64 bit</li> </ul>	4
IZ2817*	SL2ICS20	Contactless Identification Device	<ul style="list-style-type: none"> <li>□ fcoil = 13.56 MHz</li> <li>□ Cres = 23.5 pF</li> <li>□ EEPROM 1024 bit</li> <li>□ Data retention of 10 years</li> <li>□ ISO 15693</li> </ul>	2
IZ2822	MF0ICU11	Read/Write Contactless Identification Device	<ul style="list-style-type: none"> <li>□ fcoil = 13.56 MHz</li> <li>□ Cres = 50 pF</li> <li>□ EEPROM 512 bit, organized in 16 pages with 4 bytes each</li> <li>□ Data retention of 10 years</li> <li>□ Write endurance 100000 cycles</li> </ul>	4
IZ2823-5	MF1ICS50	Read/Write Contactless Identification Device	<ul style="list-style-type: none"> <li>□ fcoil = 13.56 MHz</li> <li>□ Cres = 100 pF</li> <li>□ EEPROM 1 Kbyte, organized in 16 sectors with 4 blocks of 16 bytes each</li> <li>□ Data retention of 10 years</li> <li>□ Write endurance 100000 cycles</li> </ul>	4
IZ1990	DS1990A	IC for automatic identification with 1-Wire protocol	<ul style="list-style-type: none"> <li>□ Unique 64-bit registration Number</li> <li>□ Built-In Multidrop Controller for 1-Wire Net</li> <li>□ Digital identification by momentary Contact</li> <li>□ Economically Communicates to Bus Master with a Single Digital Signal at 16.3 kbps</li> <li>□ Operating temperature range: -40°C to +85°C</li> </ul>	
IZ1991	DS1991	Multikey IC with 1-Wire protocol	<ul style="list-style-type: none"> <li>□ Unique 64-bit registration Number</li> <li>□ 1 152-bit secure read/write memory</li> <li>□ Secure memory cannot be deciphered without matching 64-bit password</li> <li>□ Memory is partitioned into 3 blocks of 384 bits each</li> <li>□ 64-bit password and ID field for each memory block</li> <li>□ 512-bit scratchpad ensures data transfer integrity</li> <li>□ Economically Communicates to Bus Master with a Single Digital Signal at 16.3 kbps</li> <li>□ Operating temperature range: -40°C to +70°C</li> </ul>	2

\* Pilot Production

• **IC for Control and Power Electronics**

Part	Pin to Pin Compatibility	Function	Package
IZ4206	TLE4206G	1 A DC Motor Driver for Servo Driver Applications	Chip
IL33035N IL33035DW	MC33035	Brushless DC Motor Controller	DIP-24 SO-24
IL33153PN	MC33153P	Single IGBT Gate Driver	DIP-8
IL9010N IL9010D	TDA1185A with build-in comparator	Triac Phase Angle Controller	DIP-14 SO-14
IL2010BN IL2010BD	U2010B	Triac Phase Angle Controller	DIP-16 SO-16
ILA1185AN ILA1185AAN ILA1185AD	TDA1185A	Triac Phase Angle Controller (ILA1185AAN - T <sub>A</sub> =-45...+85°C)	DIP-14 DIP-14 SO-14
IL33091AN IL33091AD	MC33091A	High-Side MOS Driver	DIP-8 SO-8
IL33262N IL33262D	MC33262	Power Factor Controller (T <sub>A</sub> = -40...+105°C)	DIP-8 SO-8
IL34262N IL34262D	MC34262	Power Factor Controller	DIP-8 SO-8
IL6562D	L6562	Transition-Mode PFC Controller	SO-8
ILA3354N	TFA3354	IC for Electronic Ballast's	DIP-8
IL6562	L6562	Power Factor Controller	DIP-8, SO-8
IL7101N IL7101AN IL7101D	GL7101	Earth Leakage Current Detector (U <sub>T</sub> = 4..9 mV for AN) (U <sub>T</sub> = 9..18 mV for N/D)	DIP-8 DIP-8 SO-8
IL4145AN	RV4145A	Low Power Ground Fault Interrupter	DIP-8
ILN2003AN	ULN2003A	High-Voltage High-Current Darlington Transistor Arrays	DIP-16
ILN2004AN ILN2004AD	ULN2004A	High-Voltage High-Current Darlington Transistor Arrays	DIP-16 SO-16
ILN62083N ILN62083D	TD62083AFN	8CH Darlington Sink Driver	DIP-18 SO-18
ILN62084N ILN62084D	TD62084AFN		DIP-18 SO-18
ILN62783N ILN62783D	TD62783AFN		DIP-18 SO-18
ILN62784N ILN62784D	TD62784AFN		DIP-18 SO-18
IZ6B595	TPIC6B595		Power logic 8-bit shift register for control of relays solenoids and other medium current or high voltage loads

Part	Topr (°C)	I <sub>OUT</sub> (max) (mA)	V <sub>CE</sub> (max) (V)	I <sub>IN</sub> (max) (mA)	V <sub>IN</sub> (max) (V)	V <sub>F</sub> /V <sub>R</sub> (max) (V/V)	Designation	Package
<b>7CH High-Voltage Drivers</b>								
ILN2003AN	- 20 ÷ +85	500	50	1.35	30	2/50	TTL, 5V CMOS	DIP-16
ILN2004AN ILN2004AD	- 20 ÷ +85	500	50	1.35	30	2/50	6 ~ 15V PMOS, CMOS	DIP-16 SO-16
<b>8CH High-Voltage Drivers</b>								
ILN62083N ILN62083D	- 40 ÷ +85	500	50	1.35	30	2/50	TTL, 5V CMOS	DIP-18 SO-18
ILN62084N ILN62084D	- 40 ÷ +85	500	50	0.50	30	2/50	6 ~ 15V PMOS, CMOS	DIP-18 SO-18
ILN62783N ILN62783D	- 40 ÷ +85	-500	50	0.26	30	2/50	TTL, 5V CMOS	DIP-18 SO-18
ILN62784N ILN62784D	- 40 ÷ +85	-500	50	0.13	30	2/50	6 ~ 15V PMOS, CMOS	DIP-18 SO-18
<b>8-bit shift register</b>								
IZ6B595	- 40 ÷ +125	-500	50	1 μA	7	1/50		DIP-8

# INTEGRATED CIRCUITS

## Power Electronics, Standard Analog IC

### • Automotive

Part	Pin to Pin Compatibility	Function	Package
IL33193N IL33193D	MC33193	Automotive Direction Indicator $R_S=20\text{ m}\Omega$ , $F_n=2.2$ , Duty Cycle (Normal Operation) 45÷55%, Duty Cycle (One 21 W Lamp Defect) 35÷45%, Defect Lamp Detector Threshold 42.5÷56 mV, $R_{SS}=220\ \Omega$	DIP-8 SO-8
IL33193N-01 IL33193D-01		Automotive Direction Indicator $R_S=30\text{m}\Omega$ , $F_n=2.5$ , Duty Cycle (Normal Operation) 45÷55%, Duty Cycle (One 21 W Lamp Defect) 35÷45%, Defect Lamp Detector Threshold 75÷95 mV, $R_{SS}=220\ \Omega$	DIP-8 SO-8
IL33193N-02 IL33193D-02		Automotive Direction Indicator $R_S=30\text{ m}\Omega$ , $F_n=2.5$ , Duty Cycle (Normal Operation) 45÷60%, Duty Cycle (One 21 W Lamp Defect) 40÷60%, Defect Lamp Detector Threshold 75÷95 mV, $R_{SS}=470\ \Omega$	DIP-8 SO-8
IL33193N-03 IL33193D-03	UEA1041B	Automotive Direction Indicator $R_S=30\text{ m}\Omega$ , $F_n=2.5$ , Duty Cycle (Normal Operation) 45÷55%, Duty Cycle (One 21 W Lamp Defect) 35÷45%, Defect Lamp Detector Threshold 75÷95 mV, $R_{SS}=220\ \Omega$ , Short Circuit Detector Threshold	DIP-8 SO-8
IL33197AN IL33197AD	MC33197A	Automotive Wash Wiper Timer Output Clamp Voltage ( $I_{out}=20\text{ mA}$ ) 19.5÷22 V, Internally incorporated Zener diode 20 V	DIP-8 SO-8
IL33197AN-01 IL33197AD-01		Automotive Wash Wiper Timer Output Clamp Voltage ( $I_{out}=20\text{mA}$ ) 27÷32V, Internally incorporated Zener diode 30V	DIP-8 SO-8
IL6083N IL6083N-01	U6083B	Power Control With Interference Suppression (for N-01: Duty cycle 10... 100%, $V_{S1}=24.5...28.0\text{ V}$ , $V_{S2}=18.5...22.0\text{ V}$ , $V_{Batt1}=16.7...21.0\text{ V}$ (switched on), $V_{Batt1}=18.3...22.5\text{ V}$ (switched off), $V_{TS}=10.1...10.7\text{ V}$ , $I_S=5...17\text{ mA}$ )	DIP-8
IN9014N		For light control relay IC	DIP-8
IL8190N IL8190DW	CS8190ENF16 CS8190EDWF20	Precision Air-Core Tach/Speedo Driver with Return to Zero	DIP-16 SO-20
IL33290AD	MC33290	ISO K Line Serial Link Interface	SO-8
ILA82C251D	PCA82C251T	CAN transceiver for 24 V systems	SO-8
IN2515/AN/AD W/BN/BDW	MCP2515	CAN Controller	SO-18
IL33091AN IL33091AD	MC33091A	High-Side MOS Driver	DIP-8 SO-8
IL1815N IL1815D	LM1815M	Adaptive Variable Reluctance Sensor Amplifier	DIP-14 SO-14
IL1055DW		Two-channel ignition controller	SO-16
ILE4250GS	TLE4250G□	Low-Drop Voltage Tracker (2÷36 V); 50 mA: Reverse Polarity Protection	P-TO-263-5-1 TO-220AB/5
ILE4260 ILE4260-2	TLE4260	Low-Drop Voltage Regulator 5 V; 500 mA; Reverse Polarity Protection	P-TO-220-5-12
ILE4264G IZE4264-2	TLE4264G TLE4264-2G	Low-Drop Voltage Regulator 5 V; 100 mA; Reverse Polarity Protection	P-SOT223-4-1 Chip
ILE4266G IZE4266-2	TLE4266G TLE4266-2G	Low-Drop Voltage Regulator 5 V; 100 mA; Reverse Polarity Protection	P-SOT223-4-2 Chip
ILE4267G ILE4267S	TLE4267G TLE4267S	Low-Drop Voltage Regulator 5 V; 400 mA; Reverse Polarity Protection	P-TO-220-7-180 P-TO-220-7-230
ILE4268GDW	TLE4268G	Low-Drop Voltage Regulator 5 V; 150 mA; Reverse Polarity Protection	P-DSO-20-6
ILE4270G ILE4270S ILE4270Q IL4270	TLE4270G TLE4270S	Low-Drop Voltage Regulator 5 V; 550 mA; Reverse Polarity Protection	P-TO-263-5-1 P-TO-220-5-12 P-TO-220-5-11 TO-220AB/3
ILE4271G ILE4271S	TLE4271G TLE4271S	Low-Drop Voltage Regulator 5 V; 550 mA; Reverse Polarity Protection	P-TO-220-7-180 P-TO-220-7-230

● **Automotive** (continued)

Part	Pin to Pin Compatibility	Function	Package
ILE4274V50/V85/V10	TLE4274□	Low-Drop Voltage Regulator 5 V/8.5 V/10 V; 400 mA: Reverse Polarity Protection	TO-220AB/3
ILE4275G/S	TLE4275G□	Low-Drop Voltage regulator 5 V; 400 mA: Reverse Polarity Protection	P-TO-263-5-1 TO-220AB/5
ILE4276VG/VS/V50G/V50S/V85G/V85S/V10S	TLE4276□	Low-Drop Voltage Regulator 5 V/8.5 V/10 V; 400 mA: Reverse Polarity Protection	P-TO-263-5-1 TO-220AB/5
IZE4278	TLE4278	Low-Drop Voltage Regulator 5 V; 150 mA: Reverse Polarity Protection	Chip
IZ4206	TLE4206G	1 A DC Motor Driver for Servo Driver Applications	Chip
14IVR-11	9RC6066	Monolithic Voltage Regulator for Alternator $V_R=14,1$ V; $K_T=-7,0$ mV/°C	TO-3 Jumbo
14IVR-12	9RC6066	Monolithic Voltage Regulator for Alternator $V_R=14,1$ V; $K_T=-10,0$ mV/°C	TO-3 Jumbo
14IVR-21	9RC6066	Monolithic Voltage Regulator for Alternator $V_R=14,5$ V; $K_T=-7,0$ mV/°C	TO-3 Jumbo
14IVR-22	9RC6066	Monolithic Voltage Regulator for Alternator $V_R=14,5$ V; $K_T=-10,0$ mV/°C	TO-3 Jumbo
KB1088EP1-4 KB1088EP1-01-4 KB1088EP1-03-4 KB1088EP1-11-4 KB1088EP1-12-4 KB1088EP1-12A-4 KB1088EP1-12B-4 KB1088EP1-13-4 KB1088EP1-16-4 KB1088EP1-15-4		Driver of Power Bipolar Transistor for Hybrid Voltage Regulator for Alternator	DIP-8
KB1088EP1-02-4 KB1088EP1-04-4 KB1088EP1-14-4 KB1088EP1-17-4		Driver of Power MOSFET for Hybrid Voltage Regulator for Alternator	DIP-8
KB1088NR3-4	□	Resistor Array for Hybrid Voltage Regulator for Alternator	

● **Sensors**

Part	Pin to Pin Compatibility	Function	Package
IN18B20D**	DS18B20	Programmable Resolvy 1-Wire Digital Thermometer	SO-8
IL235Z□	LM235Z□	Temperature sensor	TO-92
IL135Z□	LM135Z□	Temperature sensor	TO-92
IL1815N IL1815D	LM1815M	Adaptive Variable Reluctance Sensor Amplifier	DIP-14 SO-14
IZ7011		Analog IC for inertial sensor	Chip
IZ8001		Analog IC for vibra-resonant sensor	Chip

\*\*Under Development

● **Timers**

Part	Pin to Pin Compatibility	Function	Package
<b>Digital timers</b>			
IN555N IN555D	NE555	Timer	DIP-8 SO-8
ILC555N ILC555D	GLC555	Timer	DIP-8 SO-8

# INTEGRATED CIRCUITS

## Power Electronics, Standard Analog IC

### • Timers (continued)

Part	Pin to Pin Compatibility	Function	Package
IN556N IN556D	NE556	Dual Timer	DIP-14 SO-14
ILC556N	GLC556	Dual Timer	DIP-14
IN558N	NE558	Quad Timer	DIP-16
ILC558N	GLC558	Quad Timer	DIP-16
IN82C54N	82C54	Programmable Timer	DIP-24

### • Comparators

Part	Pin to Pin Compatibility	Function	Package
IL311AN IL311AD IL311ANM	LM311, LM211	Highly Flexible Voltage Comparators ( $T_A = -45...+85^\circ\text{C}$ )	DIP-8 SO-8 DIP-14
IL339N IL339D	LM339	Quad Comparator	DIP-14 SO-14
IL293N IL293D	LM293	Dual Comparator ( $T_A = -40...+85^\circ\text{C}$ )	DIP-8 SO-8
IL393N IL393D	LM393	Dual Comparator	DIP-8 SO-8

### • Comparators (Reference Data)

Part	$T_{opr}$ ( $^\circ\text{C}$ )	$I_{IB}$ (nA) Max	$V_{io}$ (mV) Max	$I_{io}$ (nA) Max	$A_v$ (V/mV) Min	Response Time (ns) Typ	Supply Voltage (V)	Package
<b>Single Comparators</b>								
IL311ANM	-45 ÷ +85	250	3.0	50	150	300	+15, -15	DIP-14
IL311AN								DIP-8
IL311AD								SO-8
<b>Dual Comparators</b>								
IL293N	-40 ÷ +85	250	5.0	50	50	300	±2.5 ÷ ±15 or 5.0 ÷ 30	DIP-8
IL293D								SO-8
IL393N	0 ÷ +70							DIP-8
IL393D								SO-8
<b>Quad Comparators</b>								
IL339N	0 ÷ +70	250	5.0	50	200	300	±2.5 ÷ ±15 or 5.0 ÷ 30	DIP-14
IL339D								SO-14

● **Timers (Reference Date)**

CMOS TIMERS (ILC555N/D, ILC556N, ILC558N)						BIPOlar TIMERS (IN55N/D, IN556N/D, IN558N)								
Parameter	Test Condition	Value			Unit	Test Condition	Value			Unit				
		Vcc	Min	Type			Max	Vcc	Min		Type	Max		
Supply Voltage, Vcc	- 20°C ≤ T <sub>A</sub> ≤ + 70°C		2		18	V	- 10°C ≤ T <sub>A</sub> ≤ + 70°C		4.5		16	V		
Supply Current, I <sub>CC</sub>	ILC555	2	—	60	200	μA	IN555	5	—	3000	6000	μA		
		18	—	120	300			15	—	10000	15000			
		ILC556	2	—	120			400	IN556	5	—		6000	12000
			18	—	240			600		15	—		16000	30000
		ILC558	2	—	240			800	IN558	15	—		16000	36000
			18	—	480			1200						
Timing Error	R=1– 100 kΩ, C = 0.1 μF			2.0	5.0	%	R=1– 100kΩ, C = 0.1μF			2.25		%		
Initial Accuracy, t <sub>A</sub>		5		50	200	ppm/°C				150		ppm/°C		
Drift With Temperature, ΔtA/ΔT		10			300									
Drift With Supply Voltage, ΔtA/ΔVs		15		1.0	3.0			% / V			0.3			% / V
Threshold Voltage, V <sub>TH</sub>		5	0.65xVcc	0.67xVcc	0.7xVcc	V		5		3.33		V		
Trigger Voltage, V <sub>TRIG</sub>		5	0.31xVcc	0.33xVcc	0.36xVcc	V		5	1.1	1.67	2.2	V		
Trigger Current, I <sub>TRIG</sub>		18	50			pA	V <sub>TRIG</sub> = 0V			0.5	2.0	μA		
Threshold Current, I <sub>TH</sub>		5	10											
		2	1.0											
		18	50			pA			0.1	0.25	μA			
Reset Current, I <sub>RST</sub>	V <sub>RESET</sub> = G <sub>round</sub>	5	20											
		2	2.0											
		18	0.4	0.7	1.0	V		0.4	0.7	1.0	V			
2	0.4	0.7	1.0											
Control Voltage Lead, V <sub>CV</sub>			0.65xVcc	0.67xVcc	0.69xVcc	V		15	9.0	10	11	V		
Output Voltage Low, V <sub>OL</sub>	I <sub>O</sub> = 20 mA I <sub>O</sub> = 3.2 mA	15		0.4	1.0	V	I <sub>O</sub> = 10mA I <sub>O</sub> = 50mA I <sub>O</sub> = 8mA I <sub>O</sub> = 5mA	15		0.1	0.25	V		
		5		0.2	0.4			15		0.4	0.75			
Output Voltage High, V <sub>OH</sub>	I <sub>O</sub> = 0.8 mA I <sub>O</sub> = 0.8 mA	15	14.3	14.6		V	I <sub>O</sub> = 100mA I <sub>O</sub> = 200mA I <sub>O</sub> = 100mA	15	12.75	13.3		V		
		5	4.0	4.3				15		12.5				
Rise (Fall) Time of Output, t <sub>TLH</sub> , t <sub>THL</sub>	R <sub>L</sub> = 10 MΩ, C <sub>L</sub> = 10 pF	5	35	40	75	ns				100		ns		
Guaranteed Max Osc Freq, f <sub>max</sub>	Astable Operation		500			kHz			500			kHz		
Operating Temperature, Topr			- 20 to + 70			°C			- 10 to + 70			°C		
Note:	T <sub>A</sub> = 25°C, Vcc = + 2 – + 15V unless other specified						T <sub>A</sub> = 25°C, Vcc = + 5 – + 15V unless other specified							

# INTEGRATED CIRCUITS

## Power Electronics, Standard Analog IC

### • Operational Amplifiers

Part	Pin to Pin Compatibility	Function	Package
IL258N IL258D	LM258	Dual Operational Amplifier ( $T_A = -40 \div +85^\circ\text{C}$ )	DIP-8 SO-8
IL224N IL224D	LM224	Quad Operational Amplifier ( $T_A = -40 \div +85^\circ\text{C}$ )	DIP-14 SO-14
IL324N IL324D	LM324	Quad Operational Amplifier	DIP-14 SO-14
IL358N IL358D	LM358	Dual Operational Amplifier	DIP-8 SO-8
IL1776CN, CAN IL1776CD, CAD	MC1776C	Micropower Programmable Operational Amplifier (CAN, CAD $T_A = -40 \div +85^\circ\text{C}$ )	DIP-8 SO-8
IL4558N IL4558D	GL4558	Dual Operational Amplifier	DIP-8 SO-8
IZ4560	NJM4560	Dual Operational Amplifier ( $T_A = -25 \div +75^\circ\text{C}$ )	Chip
IZ4580	NJM4580	Dual Operational Amplifier ( $T_A = -40 \div +85^\circ\text{C}$ )	Chip
IL9002N	OP-07	Low bias operational amplifier	DIP-8
IL9002AN	OP-07A	Low bias operational amplifier	DIP-8

### • Operational Amplifiers (Reference Data)

Part	Topr (°C)	I <sub>IB</sub> (nA) Max	V <sub>io</sub> (mV) Max	TC <sub>vio</sub> (μV/°C) Type	I <sub>io</sub> (nA) Max	A <sub>vol</sub> (V/mV) Min	Supply Voltage (V)		Package
							Min	Max	
<b>Micropower Programmable Operational Amplifier</b>									
IL1776CN	0 ÷ +70	10	6.0		6.0	25	±3.0	±15	DIP-8
IL1776CD									SO-8
IL1776CAN	-40 ÷ +85								DIP-8
IL1776CAD									SO-8
<b>Dual Operational Amplifier</b>									
IL258N	-40 ÷ +85	250	7.0	7.0	50	25	±2.5 +5.0	±15 +30	DIP-8
IL258D									SO-8
IL358N	0 ÷ +70								DIP-8
IL358D									SO-8
IL4558N	0 ÷ +70	500	5.0		200	20		±16	DIP-8
IL4558D									SO-8
IZ4560	-25 ÷ +75	500	6.0		200	86 dB	±4	±15	Chip
IZ4580	-40 ÷ +85	500	3.0		200	90 dB	±2	±15	Chip
<b>Quad Operational Amplifier</b>									
IL224N	-40 ÷ +85	250	7.0	7.0	50	25	±2.5 +5.0	±15 +30	DIP-14
IL224D									SO-14
IL324N	0 ÷ +70								DIP-14
IL324D									SO-14
<b>Precision Operational Amplifier</b>									
IL9002N	-60 ÷ +125	2.5	0.055	0.6	2.5	250	+3.0	±18	DIP-8
IL9002AN		4	0.105	1.3	3.5	150			

## • $\mu$ P Supervisory Circuits

Part	Pin to Pin Compatibility	Function	Package
IN1232N IN1232D	DS1232	Micro Monitor	DIP-8 SO-8
IN1705N IN1705D IN1705RN IN1705RD	DS1705	Micro Monitor (RN,RD – Push-Pull Reset Output)	DIP-8 SO-8 DIP-8 SO-8
IN1706N IN1706D IN1706SRN IN1706SRD	DS1706S	Micro Monitor (SRN, SRD - Push-Pull Reset Output)	DIP-8 SO-8 DIP-8 SO-8
IN1708N IN1708D	DS1708	Micro Monitor	DIP-8 SO-8
IL809/810LW IL809/810MW IL809/810TW IL809/810SW IL809/810RW	STM809/810LW STM809/810MW STM809/810TW STM809/810SW STM809/810RW	Reset Circuit	SOT-23-3

## • $\mu$ P Supervisory Circuits (Reference Data)

PARAMETER	IN1232N IN1232D	IN1705N IN1705D	IN1705RN IN1705RD	IN1706N IN1706D	IN1706SRN IN1706SRD	IN1708N IN1708D	IL809/810LW	IL809/810MW	IL809/810TW	IL809/810SW	IL809/810RW
							4.63	4.38	3.08	2.93	2.63
Supply Voltage, V	4.5...5.5	1.2...5.5	1.2...5.5	1.2...5.5	1.2...5.5	1.2...5.5	1.2...5.5				
Nominal Reset Threshold, V	4.37	4.65	4.65	2.93	2.93	4.40	4.63	4.38	3.08	2.93	2.63
Minimum Reset Pulse Width, ms	250	100	100	130	130	130	140				
Push-Pull RESET Output	L, H	L	H	L	H	L, H	L/H				
Watchdog	•	•	•	•	•						
Nominal Watchdog Timeout Period (s), if available	0.15	1.6	1.6	1.6	1.6		-				
Separate Watchdog Output		•	•	•	•						
Power-Fail Comparator/Reset Input		•	•	•	•	•					
Manual-Reset Input	•	•	•	•	•	•					
Supply Current in Operating Mode, $\mu$ A, max (typ)	2000 (500)	350 (100)	350 (100)	50	50	50	15 (7)				
Operating Temperature, °C	- 10 ÷ +70		- 40 ÷ +85				- 40 ÷ +85				
Package	DIP-8 SO-8	DIP-8 SO-8	DIP-8 SO-8	DIP-8 SO-8	DIP-8 SO-8	DIP-8 SO-8	SOT-23-3				

## • Voltage Regulators

Part	Pin to Pin Compatibility	Output Voltage, V	Output Current, A	Output Voltage Tolerance, %	Tested Operating Junction Temp. Range, °C	Package
------	--------------------------	-------------------	-------------------	-----------------------------	-------------------------------------------	---------

### Low Dropout Voltage Regulators

ILE4250G/S (Tracker)	TLE4250G	2 ÷ 36	0.05	0.5	T <sub>j</sub> = -40...+150	P-TO-263-5-1 TO-220AB/5
ILE4260 ILE4260-2	TLE4260S	5	0.5	5 2	T <sub>j</sub> = -40...+125	P-TO-220-5-12
ILE4264G	TLE4264G	5	0.10	2	T <sub>j</sub> = -40...+125	P-SOT223-4-1
IZE4264-2	TLE4264-2G	5	0.10	3	T <sub>j</sub> = -40...+125	Chip
ILE4266G	TLE4266G	5	0.10	2	T <sub>j</sub> = -40...+125	P-SOT223-4-2
IZE4266-2	TLE4266-2G	5	0.10	3	T <sub>j</sub> = -40...+125	Chip

# INTEGRATED CIRCUITS

## Power Electronics, Standard Analog IC

### • Voltage Regulators (continued)

Part	Pin to Pin Compatibility	Output Voltage, V	Output Current, A	Output Voltage Tolerance, %	Tested Operating Junction Temp. Range, °C	Package
ILE4267G	TLE4267G	5	0.4	2	Tj= -40...+125	P-TO-220-7-180
ILE4267S	TLE4267S					P-TO-220-7-230
ILE4268GDW	TLE4268G	5	0.15	2	Tj= -40...+125	SO-20
ILE4270G	TLE4270G	5	0.55	2	Tj= -40...+125	P-TO-263-5-1
ILE4270S	TLE4270S					P-TO-220-5-12
ILE4270Q						P-TO-220-5-11
ILE4270 (without "RESET")		5	0.55	2	Tj= -40...+125	TO-220AB/3
ILE4271G	TLE4271G	5	0.55	2	Tj= -40...+125	P-TO-220-7-180
ILE4271S	TLE4271S					P-TO-220-7-230
ILE4274V50/V8 5/V10	TLE4274	5; 8.5; 10	0.4	4	Tj= -40...+150	TO-220AB/3
ILE4275G/S	TLE4275G	5	0.4	2	Tj= -40...+150	P-TO-263-5-1
ILE4276VG/VS/ V50G/V50S/V8 5G/V85S/V10G/ V10S	TLE4276	5; 8.5; 10	0.4	4	Tj= -40...+150	TO-220AB/5
IZE4278	TLE4278	5	0.15	2	Tj= -40...+150	Chip
IZ1734-33	SSAIC1734-33	3.3	0.3	2	Tj= -40...+125	Chip
IZ1734-50	SSAIC1734-50	5	0.3	2		
IZ1735-33	SSAIC1735-33	3.3	0.5	2		
IZ1735-50	SSAIC1735-50	5	0.5	2		
IL5212G	CS5201 LD1117S	1.2	0.8	5	Tj= 0...+125	P-SOT-223-4-1
IL5218G		1.8	0.8	2		
IL5225G		2.5	0.8	2		
IL5228G		2.85	0.8	2		
IL5230G		3.0	0.8	2		
IL5233G		3.3	0.8	2		
IL5250G		5.0	0.8	2		

#### Dual Positive Voltage Regulators

ILA8133A	TDA8133A	5.1;8	0.75	2	Tj= 0...+130	TO-220AB/7
ILA8138A	TDA8138A	5.1; 12	1.0	2	Tj= 0...+130	TO-220AB/7

#### Adjustable Voltage Regulators

Part	Pin to Pin Compatibility	Function	Package
IL317	LM317T	Adjustable Output Positive Voltage Regulator 1.5 A; (1.2...37 V) Tj=-40...+125°C	TO-220AB/3
IZ317L	LM317L	Adjustable Output Positive Voltage Regulator 0.1 A; (1.2...37 V) Tj=-40...+125°C	Chip
IL2931CD	LM2931C	Adjustable Dropout Voltage Regulator 0.1 A; (3...24 V) Tj= -40...+125°C	SO-8
IL5200G	CS5201 LD1117S	Adjustable Dropout Voltage Regulator 0.8 A; (1.25 ... 13.5 V) Tj= 0...+125°C	P-SOT-223-4-1

#### Switching Regulators

Part	Pin to Pin Compatibility	Function	Package
IL2576 – 3.3 IL2576 – 5 IL2576 – 12 IL2576 – 15 IL2576 – ADJ	LM2576 – 3.3 LM2576 – 5 LM2576 – 12 LM2576 – 15 LM2576 – ADJ	3.0 A, 15 V, Step-Down Switching Regulator	TO-220 AB/5
IL2596 – 3.3 IL2596 – 5 IL2596 – 12 IL2596 – ADJ	LM2596 – 3.3 LM2596 – 5 LM2596 – 12 LM2596 – ADJ	Power Converter 150 kHz 3 A Step-Down Voltage Regulator	TO-220 AB/5

• **Voltage Regulators** (continued) **Switching Regulators**

Part	Pin to Pin Compatibility	Function	Package
IL1501 – 33 IL1501 – 50 IL1501 – 12 IL1501	AP1501 – 3.3V AP1501 – 5V AP1501 – 12V AP1501 – ADJ	150 kHz, 3 A PWM Buck DC/DC Converter	TO-220 AB/5
IZ9261 – 15 IZ9261 – 25 IZ9261 – 33 IZ9261 – 50	RT9261 – 15 RT9261 – 25 RT9261 – 33 RT9261 – 50	VFM Step-up DC/DC Converter	Chip
IL34063AN IL34063AD	MC34063A	Step-Up /Down/inverting Switching Regulator ( $I_{sw} \leq 1.5A$ )	Dip-8 SO-8
IL33063AN IL33063AD	MC33063A	Step-Up /Down/inverting Switching Regulator $T_A = (-40...+85^{\circ}C)$	Dip-8 SO-8
IL34063S1N/D**	MC34063A	Step-Up/Down/inverting Switching Regulator ( $I_{sw} \leq 0.8 A$ )	Chip
IZ1583**	MP1583	Step-Down Switching Regulator	Chip
IZ1591**	MP1591	Step-Down Switching Regulator	Chip
IZ1412	MP1412	2A, 23V, 380KHz Step-Down Converter	Chip
IZ2307	MP2307	3A, 23V, 340KHz Synchronous Rectified Step-Down Converter	Chip

**Switching Regulators (Reference Data)**

Part	T (°C)	I <sub>OUT</sub> (A)	V <sub>IN</sub> (V)		V <sub>OUT</sub> (V)	F <sub>sw</sub> (typ) (kHz)	I <sub>STBY</sub> (typ) (µA)	Package
			Min	Max				
<b>Step-Down (Buck)</b>								
IL2576	- 40 ÷ +125	3	6.0	40	3.3, 5, 12, 15, Adj (1.23 to 37)	52	80	TO-220AB/5
IL2596	- 40 ÷ +125	3	4.5	40	3.3, 5, 12, Adj (1.23 to 37)	150	80	TO-220AB/5
IL1501	- 40 ÷ +125	3	4.5	40	3.3, 5, 12, Adj (1.23 to 37)	150	150	TO-220AB/5
IZ1583	- 40 ÷ +85	3	4.75	23	Adj (1.22 to 21)	385		Chip
IZ1591	- 40 ÷ +85	2	6.5	32	Adj (1.2 to 21)	330		Chip
IZ1412	- 40 ÷ +85	2	4.75	23	Adj (0.92 to 16)	380	23	Chip
IZ2307	- 40 ÷ +85	3	4.75	23	Adj (0.925 to 20)	340	0.3	Chip
<b>Step-Up</b>								
IZ9261	- 25 ÷ +85	0.250	1	4.5	1.5, 2.5, 3.3, 5	120	0.5	Chip
<b>Step-Up /Down/Inverting</b>								
IL33063AN IL33063AD	- 40 ÷ +85	1.5	3.0	40	Adj	33	2.5 mA	Dip-8 SO-8
IL34063AN IL34063AD	0 ÷ +70	1.5	3.0	40	Adj	33	2.5 mA	Dip-8 SO-8
IL34063S1**	0 ÷ +70	0.8	3.0	40	Adj	33	2.5 mA	Chip

• **PWM Controllers**

Part	Pin to Pin Compatibility	Function	Package
IL494N	TL494IN	Pulse-Width-Modulation Control Circuit	DIP-16
IL6083N IL6083N-01	U6083B	Power Control With Interference Suppression (for IL6083N N-01: Duty cycle 10... 100%, V <sub>S1</sub> =24.5...28.0 V, V <sub>S2</sub> =18.5...22.0 V, V <sub>Batt1</sub> =16.7...21.0 V (switched on), V <sub>Batt1</sub> =18.3...22.5 V (switched off), V <sub>TS</sub> =10.1... 10.7 V, I <sub>S</sub> =5...17 mA)	DIP-8
IL44608N40	MC44608P40	SMPS Controller	DIP-8
IL44608N75	MC44608P75		DIP-8
IL44608N100	MC44608P100		DIP-8

\*\*Under Development

• *Voltage Regulators (Reference Date)*

Parameter	ILE4250G/S (Tracker)	ILE4260	ILE4260-2	ILE4264G	IZE4264-2	ILE4266G	IZE4266-2	ILE4267G/S	ILE4268GDW	ILE4270G/S/Q	IL4270	ILE4271G/S	ILE4274V50/V8 5/V10	ILE4275G/S	ILE4276V/G/V/S/ V50G/V50S/V85 G/V85S/V10G/V 10S	IZE4278	
Output current, mA	≤50	≤500		≤100	≤100	≤100	≤100	≤400	≤150	≤550		≤550	≤400	≤400	≤400	≤150	
Input voltage (max), V	45	42 60 (≤400ms)		45	45	45	45	42 60 (≤400ms)	45	42 65 (≤400ms)		42 65 (≤400ms)	45	45	45	45	
Output voltage, V	2÷36	5		5	5	5	5	5	5	5		5	5; 8.5; 10	5	5; 8.5; 10	5	
Drop voltage, V	≤0.3	≤0.5		≤0.5	≤0.5	≤0.5	≤0.5	≤0.6	≤0.5	≤0.7		≤0.7	≤0.5	≤0.5	≤0.5	≤0.5	
Output voltage tolerance, %	I <sub>o</sub> max	0.5	5	2	2	3	2	3	2	2		2	4	2	4	2	
	I <sub>o</sub> = 50 mA					2		2									
Current consumption, mA	I <sub>o</sub> = max			≤65	≤15			≤60	≤20			≤75	≤75	≤30	≤22	≤25	≤12
	I <sub>o</sub> = 0.1 mA					≤0.07		≤0.07									
	I <sub>o</sub> = 1 mA	0.15				0.4		-					0.22	0.20	0.22		
	I <sub>o</sub> ≤ 30 mA	≤3															
	I <sub>o</sub> = 50 mA					≤4		≤4									
Shot-circuit proof	•	•		•	•	•	•	•	•	•	•	•	•	•	•	•	
Overvoltage protection		•		•	•	•	•	•	•	•	•	•	•	•	•	•	
Reverse polarity protection	•	•		•	•	•	•	•	•	•	•	•	•	•	•	•	
Overtemperature protection	•	•		•	•	•	•	•	•	•	•	•	•	•	•	•	
Adjustable Reset	Time		•					•	•	•		•		•		•	
	Threshold		•					•	•	•		•		•		•	
On/off logic								•									
Watchdog									•			•				•	
Inhibit Input						•	•	•				•			•		
Junction Temperature, °C	- 40 ÷ +150							- 40 ÷ +125							- 40 ÷ +150	- 40 ÷ +125	
Package	P-TO-263-5-1 TO-220AB/5	TO-220AB/5		P-SOT223-4-1	Chip	P-SOT223-4-2	Chip	P-TO-220-7-180 P-TO-220-7-230	SO-20	P-TO-263-5-1 P-TO-220-5-12 P-TO-220-5-11	TO-220AB/3	P-TO-220-7-180 P-TO-220-7-230	TO-220AB/3	P-TO-263-5-1 TO-220AB/5	P-TO-263-5-1 TO-220AB/5	Chip	



• *Voltage Regulators (Reference Date)*

Parameter	IL5212G	IL5218G	IL5225G	IL5228G	IL5230G	IL5233G	IL5250G	IL5200G	IZ1734-33	IZ1734-50	IZ1735-33	IZ1735-50	IL2931CD	IL317	IZ317L
Output current, mA	≤800	≤800	≤800	≤800	≤800	≤800	≤800	≤800	≤300	≤300	≤500	≤500	100	1500	100
Input voltage (max), V	15	8	10	10	12	15	15	15	12	12	12	12	40	40	
Output voltage, V	1.2	1.8	2.5	2.85	3	3.3	5	1.25-13.5	3.3	5	3.3	5	3-24	1.2-37	
Drop voltage, V	≤1.2	≤1.2	≤1.2	≤1.2	≤1.2	≤1.2	≤1.2	≤1.2	0.47	0.4	0.65	0.51	≤0.6	≤2.5	
Output voltage tolerance, %	$I_Q$ max		5	2	2	2	2	2	2	2	2	2	5	0.07%/V	
Current consumption, mA	$I_Q$ = max		10	10	10	10	10	10	10	0.08	0.08	0.09	0.09	6	0.1 ( $I_O=0.5A$ )
Shot-circuit proof	•	•	•	•	•	•	•	•	•	•	•	•	•	•	
Overvoltage protection													•		
Reverse polarity protection													•		
Overtemperature protection	•	•	•	•	•	•	•	•					•	•	
On/off logic													•		
Junction Temperature, °C	0 ÷ +125								- 40 ÷ +125						
Package	P-SOT223-4-1								Chip				SO-8	TO-220AB/3	Chip

# INTEGRATED CIRCUITS

## Standard Digital Logic IC

### • IW4000AN, D(DW) Series

Part	Pin to Pin Compatibility	Function	Package
IW4001AN,AD	CD4001AN,AD	Quad 2-Input NOR Gate	DIP-14, SO-14
IW4002AN,AD	CD4002AN,AD	Dual 4-Input NOR Gate	DIP-14, SO-14
IW4011AN,AD	CD4011AN,AD	Quad 2-Input NAND Gate	DIP-14, SO-14
IW4012AN,AD	CD4012AN,AD	Dual 4-Input NAND Gate	DIP-14, SO-14
IW4013AN,AD	CD4013AN,AD	Dual D-Type Flip-Flop	DIP-14, SO-14
IW4015AN,AD	CD4015AN,AD	Dual 4-Bit Shift Register	DIP-16, SO-16
IW4017AN,AD	CD4017AN,AD	Decade Counter/Driver	DIP-16, SO-16
IW4019AN,AD	CD4019AN,AD	Quad AND-OR Gate	DIP-16, SO-16
IW4020AN,AD	CD4020AN,AD	14-Bit Binary Divide Counter	DIP-16, SO-16
IW4023AN,AD	CD4023AN,AD	Triple 3-Input NAND Gate	DIP-14, SO-14
IW4025AN,AD	CD4025AN,AD	Triple 3-Input NOR Gate	DIP-14, SO-14
IW4028AN,AD	CD4028AN,AD	BCD-to-Decimal Decoder	DIP-16, SO-16
IW4029AN,AD	CD4029AN,AD	Binary or BCD-Decade Counter	DIP-16, SO-16
IW4030AN,AD	CD4030AN,AD	Quad Exclusive-OR Gate	DIP-14, SO-14
IW4034AN,ADW	CD4034AN,AD	8-Bit Shift Register	DIP-24, SO-24
IW4043AN,AD	CD4043AN,AD	Quad NOR R-S Latch (3-State)	DIP-16, SO-16
IW4049AN,AD	CD4049AN,AD	Hex Buffer/Converter	DIP-14, SO-14
IW4050AN,AD	CD4050AN,AD	Hex Buffer/Converter	DIP-16, SO-16
IW4051AN,AD	CD4051AN,AD	Single 8-Channel Multiplexer/Demultiplexer	DIP-16, SO-16
IW4052AN,AD	CD4052AN,AD	Differential 4-Channel Multiplexer/Demultiplexer	DIP-16, SO-16
IW4066AN,AD	CD4066AN,AD	Quad Bilateral Switch	DIP-14, SO-14
IW4069AN,AD	CD4069AN,AD	Hex Inverter	DIP-14, SO-14
IW4093AN,AD	CD4093AN,AD	Quad 2-Input NAND Schmitt Trigger	DIP-14, SO-14
IW4502AN,AD	CD4502AN,AD	Hex Inverter/Buffer	DIP-16, SO-16
IW4516AN,AD	CD4516AN,AD	Presetable Binary Up/Down Counter	DIP-16, SO-16
IW4520AN,AD	CD4520AN,AD	Dual Binary Up Counter	DIP-16, SO-16

### • IW4000BN, D(DW) Series

Part	Pin to Pin Compatibility	Function	Package
IW4001BN,BD	CD4001BN,BD	Quad 2-Input NOR Gate	DIP-14, SO-14
IW4002BN,BD	CD4002BN,BD	Dual 4-Input NOR Gate	DIP-14, SO-14
IW4006BN,BD	CD4006BN,BD	18-Bit Static Shift Register	DIP-14, SO-14
IW4008BN,BD	CD4008BN,BD	4-Bit Full Adder	DIP-16, SO-16
IW4011BN,BD	CD4011BN,BD	Quad 2-Input NAND Gate	DIP-14, SO-14
IW4012BN,BD	CD4012BN,BD	Dual 4-Input NAND Gate	DIP-14, SO-14
IW4013BN,BD	CD4013BN,BD	Dual D-Type Flip-Flop	DIP-14, SO-14
IW4015BN,BD	CD4015BN,BD	Dual 4-Bit Static Shift Register	DIP-16, SO-16
IW4016BN,BD	CD4016BN,BD	Quad Bilateral Switch	DIP-14, SO-14
IW4017BN,BD	CD4017BN,BD	Decade Counter/Driver	DIP-16, SO-16
IW4018BN,BD	CD4018BN,BD	Presetable Divide-by-N Counter	DIP-16, SO-16
IW4019BN,BD	CD4019BN,BD	Quad AND-OR Gate	DIP-16, SO-16
IW4020BN,BD	CD4020BN,BD	14-Bit Binary Divide Counter	DIP-16, SO-16
IW4021BN,BD	CD4021BN,BD	8-Bit Shift Register	DIP-16, SO-16
IW4022BN,BD	CD4022BN,BD	Divide-by-8 Counter/Divider	DIP-16, SO-16

● **IW4000BN, D(DW) Series** (continued)

Part	Pin to Pin Compatibility	Function	Package
IW4023BN,BD	CD4023BN,BD	Triple 3-Input NAND Gate	DIP-14, SO-14
IW4025BN,BD	CD4025BN,BD	Triple 3-Input NOR Gate	DIP-14, SO-14
IW4027BN,BD	CD4027BN,BD	Dual J-K Flip-Flop	DIP-16, SO-16
IW4028BN,BD	CD4028BN,BD	BCD-to-Decimal Decoder	DIP-16, SO-16
IW4029BN,BD	CD4029BN,BD	Binary or BCD-Decade Counter	DIP-16, SO-16
IW4030BN,BD	CD4030BN,BD	Quad Exclusive-OR Gate	DIP-14, SO-14
IW4034BN,BDW	CD4034BN,BD	8-Bit Shift Register	DIP-24, SO-24
IW4035BN,BD	CD4035BN,BD	4-Bit Parallel-In/Parallel-Out Shift Register	DIP-16, SO-16
IW4040BN,BD	CD4040BN,BD	12-Bit Binary Counter	DIP-16, SO-16
IW4042BN,BD	CD4042BN,BD	Quad Clocked D-Latch	DIP-16, SO-16
IW4043BN,BD	CD4043BN,BD	Quad NOR R-S Latch (3-State)	DIP-16, SO-16
IW4049BN,BD	CD4049BN,BD	Hex Buffer/Converter	DIP-16, SO-16
IW4050BN,BD	CD4050BN,BD	Hex Buffer/Converter	DIP-16, SO-16
IW4051BN,BD	CD4051BN,BD	8-Channel Analog Multiplexer/Demultiplexer	DIP-16, SO-16
IW4052BN,BD	CD4052BN,BD	Dual 4-Channel Analog Multiplexer/Demultiplexer	DIP-16, SO-16
IW4053BN,BD	CD4053BN,BD	Triple 2-Channel Analog Multiplexer/Demultiplexer	DIP-16, SO-16
IW4059AN,ADW	CD4059AN,AD	Programmable Counter	DIP-24, SO-24
IW4060BN,BD	CD4060BN,BD	14-Bit Binary Divide/ Counter	DIP-16, SO-16
IW4066BN,BD	CD4066BN,BD	Quad Bilateral Switch	DIP-14, SO-14
IW4068BN,BD	CD4068BN,BD	8-Input NAND Gate	DIP-14, SO-14
IW4069UBN,UBD	CD4069UBN,UBD	Hex Inverter	DIP-14, SO-14
IW4070BN,BD	CD4070BN,BD	Quad Exclusive-OR Gate	DIP-14, SO-14
IW4071BN,BD	CD4071BN,BD	Quad 2-Input OR Gate	DIP-14, SO-14
IW4072BN,BD	CD4072BN,BD	Dual 4-Input OR Gate	DIP-14, SO-14
IW4073BN,BD	CD4073BN,BD	Triple 3-Input AND Gate	DIP-14, SO-14
IW4075BN,BD	CD4075BN,BD	Triple 3-Input OR Gate	DIP-14, SO-14
IW4077BN,BD	CD4077BN,BD	Quad Exclusive-NOR Gate	DIP-14, SO-14
IW4081BN,BD	CD4081BN,BD	Quad 2-Input AND Gate	DIP-14, SO-14
IW4093BN,BD	CD4093BN,BD	Quad 2-Input NAND Schmitt Trigger	DIP-14, SO-14
IW4098BN,BD	CD4098BN,BD	Dual Monostable Multivibrator	DIP-16, SO-16
IW40107BN,BD	CD40107BN,BD	Dual 2-Input NAND Buffer/Driver	DIP-14, SO-14
IW4502BN,BD	CD4502BN,BD	Hex Inverter/Buffer	DIP-16, SO-16
IW4503BN,BD	CD4503BN,BD	Hex Buffer	DIP-16, SO-16
IW4511BN,BD	CD4511BN,BD	BCD-to-7-Segment Latch Decoder/Driver	DIP-16, SO-16
IW4516BN,BD	CD4516BN,BD	Presetable Binary Up/Down Counter	DIP-16, SO-16
IW4518BN,BD	CD4518BN,BD	Dual BCD Up Counter	DIP-16, SO-16
IW4519BN,BD	CD4519BN,BD	Quad AND/OR Select Gate	DIP-16, SO-16
IW4520BN,BD	CD4520BN,BD	Dual Binary Up Counter	DIP-16, SO-16
IW4528BN,BD	CD4528BN,BD	Dual Monostable Multivibrator	DIP-16, SO-16
IW4531BN,BD	NEF4531BN,BD	12-Bit Checker Tree	DIP-16, SO-16
IW4541BN,BD	CD4541BN,BD	Programmable Timer	DIP-14, SO-14
IW4543BN,BD	CD4543BN,BD	BCD-to-7-Segment Latch/Decoder/Driver for Liquid-Crystal Display	DIP-16, SO-16
IW4585BN,BD	CD4585BN,BD	4-Bit Comparator	DIP-16, SO-16

# INTEGRATED CIRCUITS

## Standard Digital Logic IC

### • IN74ACXXXXN, D(DW) Series

Part	Pin to Pin Compatibility	Function	Package
IN74AC00N,D	MC74AC00N,D	Quad 2-Input NAND Gate	DIP-14, SO-14
IN74AC02N,D	MC74AC02N,D	Quad 2-Input NOR Gate	DIP-14, SO-14
IN74AC04N,D	MC74AC04N,D	Hex Inverter	DIP-14, SO-14
IN74AC05N,D	CD74AC05N,D	Hex Inverter, OC	DIP-14, SO-14
IN74AC08N,D	MC74AC08N,D	Quad 2-Input AND Gate	DIP-14, SO-14
IN74AC10N,D	MC74AC10N,D	Triple 3-Input Positive-NAND Gate	DIP-14, SO-14
IN74AC11N,D	MC74AC11N,D	Triple 3-Input AND Gate	DIP-14, SO-14
IN74AC14N,D	MC74AC14N,D	Hex Schmitt-Trigger Inverter	DIP-14, SO-14
IN74AC20N,D	CD74AC20N,D	Dual 4-Input NAND Gate	DIP-14, SO-14
IN74AC21N,D	own	Dual 4-Input AND Gate	DIP-14, SO-14
IN74AC27N,D	own	Triple 3-Input NOR Gate	DIP-14, SO-14
IN74AC32N,D	MC74AC32N,D	Quad 2-Input OR Gate	DIP-14, SO-14
IN74AC34N,D	own	Hex Non-Inverter	DIP-14, SO-14
IN74AC74N,D	MC74AC74N,D	Dual D-Type Flip-Flop	DIP-14, SO-14
IN74AC86N,D	MC74AC86N,D	Quad 2-Input Exclusive-OR Gate	DIP-14, SO-14
IN74AC109N,D	MC74AC109N,D	Dual J-K Positive-Edge-Triggered Flip-Flop	DIP-16, SO-16
IN74AC112N,D	CD74AC112N,D	Dual J-K Negative-Edge-Triggered Flip-Flop	DIP-16, SO-16
IN74AC125N,D	T74AC125N,D	Quad 3-State Buffer	DIP-14, SO-14
IN74AC132N,D	MC74AC132N,D	Quad 2-Input NAND Schmitt-Trigger Inverter	DIP-14, SO-14
IN74AC138N,D	MC74AC138N,D	3-8 Decoder/Demultiplexer	DIP-16, SO-16
IN74AC139N,D	MC74AC139N,D	Dual 2-4 Decoder/Demultiplexer	DIP-16, SO-16
IN74AC151N,D	MC74AC151N,D	8-1 Data Selector/Multiplexer	DIP-16, SO-16
IN74AC153N,D	MC74AC153N,D	Dual 4-1 Data Selector/Multiplexer	DIP-16, SO-16
IN74AC157N,D	MC74AC157N,D	Quad 2-1 Data Selector/Multiplexer	DIP-16, SO-16
IN74AC158N,D	MC74AC158N,D	Quad 2-1 Data Selector/Multiplexer, INV	DIP-16, SO-16
IN74AC161N,D	MC74AC161N,D	4-Bit Synchronous Binary Counter, Asynchronous Reset	DIP-16, SO-16
IN74AC163N,D	MC74AC163N,D	4-Bit Synchronous Binary Counter, Synchronous Reset	DIP-16, SO-16
IN74AC164N,D	CD74AC164N,D	8-Bit Serial-In Parallel-Out Shift Register	DIP-14, SO-14
IN74AC174N,D	MC74AC174N,D	Hex D-Type Flip-Flop	DIP-16, SO-16
IN74AC175N,D	MC74AC175N,D	Quad D-Type Flip-Flop	DIP-16, SO-16
IN74AC192N,D	MC74AC192N,D	Synchronous Decade Up/Down Counter	DIP-16, SO-16
IN74AC193N,D	CD74AC193N,D	4-Bit Synchronous Binary Up/Down Counter	DIP-16, SO-16
IN74AC240N,DW	MC74AC240N,D	Octal Buffer/Line Driver, INV (3-State)	DIP-20, SO-20
IN74AC241N,DW	MC74AC241N,D	Octal Buffer/Line Driver, NINV (3-State)	DIP-20, SO-20
IN74AC244N,DW	MC74AC244N,D	Octal Buffer/Line Driver NINV (3-State)	DIP-20, SO-20
IN74AC245N,DW	MC74AC245N,D	Octal Bus Transceiver, NINV (3-State)	DIP-20, SO-20
IN74AC251N,D	MC74AC251N,D	8-1 Data Selector/Multiplexer (3-State)	DIP-16, SO-16
IN74AC253N,D	MC74AC253N,D	Dual 4-1 Data Selector/Multiplexer, NINV (3-State)	DIP-16, SO-16
IN74AC257N,D	MC74AC257N,D	Quad 2-1 Data Selector/Multiplexer, NINV (3-State)	DIP-16, SO-16
IN74AC258N,D	MC74AC258N,D	Quad 2-1 Data Selector/Multiplexer, INV (3-State)	DIP-16, SO-16
IN74AC273N,DW	MC74AC273N,D	Octal D-Type Flip-Flop	DIP-20, SO-20
IN74AC299N,DW	MC74AC299N,D	8-Bit Universal Shift/Storage Register (3-State)	DIP-20, SO-20
IN74AC323N,DW	CD74AC323N,D	8-Bit Universal Shift/Storage Register (3-State)	DIP-20, SO-20
IN74AC373N,DW	MC74AC373N,D	Octal D-Type Latch (3-State)	DIP-20, SO-20
IN74AC374N,DW	MC74AC374N,D	Octal D-Type Flip-Flop (3-State)	DIP-20, SO-20
IN74AC533N,DW	MC74AC533N,D	Octal D-Type Latch, INV (3-State)	DIP-20, SO-20
IN74AC534N,DW	MC74AC534N,D	Octal D-Type Flip-Flop, NINV (3-State)	DIP-20, SO-20
IN74AC563N,DW	MC74AC563N,D	Octal D-Type Transparent Latch	DIP-20, SO-20
IN74AC564N,DW	MC74AC564N,D	Octal Edge-Triggered Flip-Flop	DIP-20, SO-20
IN74AC573N,DW	MC74AC573N,D	Octal Transparent Latch (3-State)	DIP-20, SO-20
IN74AC574N,DW	MC74AC574N,D	Octal D-Type Flip-Flop, NINV (3-State)	DIP-20, SO-20
IN74AC620N,DW	MC74AC620N,D	Octal Bidirectional Bus Transceiver, INV	DIP-20, SO-20
IN74AC623N,DW	MC74AC623N,D	Octal Bidirectional Bus Transceiver, NINV	DIP-20, SO-20
IN74AC640N,DW	MC74AC640N,D	Octal Bus Transceiver (3-State)	DIP-20, SO-20

• **IN74ACXXXXN, D(DW) Series** (continued)

Part	Pin to Pin Compatibility	Function	Package
IN74AC643N,DW	MC74AC643N,D	Octal Bus Transceiver (3-State)	DIP-20, SO-20
IN74AC651N,DW	CD74AC651N,D	Octal Bus Transceiver/Register, INV (3-State)	DIP-24, SO-24
IN74AC652N,DW	own	Octal Bus Transceiver/Register, NINV (3-State)	DIP-24, SO-24
IN74AC810N,D	MC74AC810N,D	Quad Exclusive-NOR Gate	DIP-14, SO-14
IN74AC4006N,D	own	18-Bit Static Shift Register	DIP-14, SO-14
IN74AC4015N,D	own	Dual 4-Bit Static Shift Register	DIP-16, SO-16
IN74AC4035N,D	own	4-Bit Parallel-In/Parallel-Out Shift Register	DIP-16, SO-16
IN74AC4520N,D	own	Dual 4-Bit Synchronous Binary Counter	DIP-16, SO-16

• **IN74ACTXXXXN, D(DW) Series**

Part	Pin to Pin Compatibility	Function	Package
IN74ACT00N,D	MC74ACT00N,D	Quad 2-Input NAND Gate	DIP-14, SO-14
IN74ACT02N,D	MC74ACT02N,D	Quad 2-Input NOR Gate	DIP-14, SO-14
IN74ACT04N,D	CD74ACT04N,D	Hex Inverter	DIP-14, SO-14
IN74ACT05N,D	CD74ACT05N,D	Hex Inverter, OC	DIP-14, SO-14
IN74ACT08N,D	MC74ACT08N,D	Quad 2-Input AND Gate	DIP-14, SO-14
IN74ACT10N,D	MC74ACT10N,D	Triple 3-Input Positive-NAND Gate	DIP-14, SO-14
IN74ACT11N,D	MC74ACT11N,D	Triple 3-Input AND Gate	DIP-14, SO-14
IN74ACT14N,D	MC74ACT14N,D	Hex Schmitt-Trigger Inverter	DIP-14, SO-14
IN74ACT20N,D	CD74ACT20N,D	Dual 4-Input NAND Gate	DIP-14, SO-14
IN74ACT21N,D	own	Dual 4-Input Positive-AND Gate	DIP-14, SO-14
IN74ACT27N,D	own	Triple 3-Input NOR Gate	DIP-14, SO-14
IN74ACT32N,D	MC74ACT32N,D	Quad 2-Input OR Gate	DIP-14, SO-14
IN74ACT34N,D	own	Hex Non-Inverter	DIP-14, SO-14
IN74ACT74N,D	MC74ACT74N,D	Dual D-Type Flip-Flop	DIP-14, SO-14
IN74ACT86N,D	MC74ACT86N,D	Quad 2-Input Exclusive-OR Gate	DIP-14, SO-14
IN74ACT109N,D	MC74ACT109N,D	Dual J-K Positive-Edge-Triggered Flip-Flop	DIP-16, SO-16
IN74ACT112N,D	MC74ACT112N,D	Dual J-K Negative-Edge-Triggered Flip-Flop	DIP-16, SO-16
IN74ACT125N,D	own	Quad 3-State Buffer	DIP-14, SO-14
IN74ACT132N,D	MC74ACT132N,D	Quad 2-Input NAND Schmitt-Trigger Inverter	DIP-14, SO-14
IN74ACT138N,D	MC74ACT138N,D	3-8 Decoder/Demultiplexer	DIP-16, SO-16
IN74ACT139N,D	MC74ACT139N,D	Dual 2-4 Decoder/Demultiplexer	DIP-16, SO-16
IN74ACT151N,D	MC74ACT151N,D	8-1 Data Selector/Multiplexer	DIP-16, SO-16
IN74ACT153N,D	MC74ACT153N,D	Dual 4-1 Data Selector/Multiplexer	DIP-16, SO-16
IN74ACT157N,D	MC74ACT157N,D	Quad 2-1 Data Selector/Multiplexer	DIP-16, SO-16
IN74ACT158N,D	MC74ACT158N,D	Quad 2-1 Data Selector/Multiplexer, INV	DIP-16, SO-16
IN74ACT161N,D	MC74ACT161N,D	4-Bit Synchronous Binary Counter, Asynchronous Reset	DIP-16, SO-16
IN74ACT163N,D	MC74ACT163N,D	4-Bit Synchronous Binary Counter, Synchronous Reset	DIP-16, SO-16
IN74ACT164N,D	CD74ACT164N,D	8-Bit Serial-In Parallel-Out Shift Register	DIP-14, SO-14
IN74ACT174N,D	MC74ACT174N,D	Hex D-Type Flip-Flop	DIP-16, SO-16
IN74ACT175N,D	CD74ACT175N,D	Quad D-Type Flip-Flop	DIP-16, SO-16
IN74ACT192N,D	own	Synchronous Decade Up/Down Counter	DIP-16, SO-16
IN74ACT193N,D	CD74ACT193N,D	4-Bit Synchronous Binary Up/Down Counter	DIP-16, SO-16
IN74ACT240N,DW	MC74ACT240N,D	Octal Buffer/Line Driver, INV (3-State)	DIP-20, SO-20
IN74ACT241N,DW	MC74ACT241N,D	Octal Buffer/Line Driver, NINV (3-State)	DIP-20, SO-20
IN74ACT244N,DW	MC74ACT244N,D	Octal Buffer/Line Driver NINV (3-State)	DIP-20, SO-20
IN74ACT245N,DW	MC74ACT245N,D	Octal Bus Transceiver, NINV (3-State)	DIP-20, SO-20
IN74ACT251N,D	MC74ACT251N,D	8-1 Data Selector/Multiplexer (3-State)	DIP-16, SO-16
IN74ACT253N,D	MC74ACT253N,D	Dual 4-1 Data Selector/Multiplexer, NINV (3-State)	DIP-16, SO-16
IN74ACT257N,D	MC74ACT257N,D	Quad 2-1 Data Selector/Multiplexer, NINV (3-State)	DIP-16, SO-16
IN74ACT258N,D	MC74ACT258N,D	Quad 2-1 Data Selector/Multiplexer, INV (3-State)	DIP-16, SO-16
IN74ACT273N,DW	MC74ACT273N,D	Octal D-Type Flip-Flop	DIP-20, SO-20
IN74ACT299N,DW	MC74ACT299N,D	8-Bit Universal Shift/Storage Register (3-State)	DIP-20, SO-20

# INTEGRATED CIRCUITS

## Standard Digital Logic IC

### • IN74ACTXXXN, D(DW) Series (continued)

Part	Pin to Pin Compatibility	Function	Package
IN74ACT323N,DW	MC74ACT323N,D	8-Bit Universal Shift/Storage Register (3-State)	DIP-20, SO-20
IN74ACT373N,DW	MC74ACT373N,DW	Octal D-Type Latch (3-State)	DIP-20, SO-20
IN74ACT374N,DW	MC74ACT374N,DW	Octal D-Type Flip-Flop (3-State)	DIP-20, SO-20
IN74ACT533N,DW	MC74ACT533N,DW	Octal D-Type Latch, INV (3-State)	DIP-20, SO-20
IN74ACT534N,DW	MC74ACT534N,DW	Octal D-Type Flip-Flop, NINV (3-State)	DIP-20, SO-20
IN74ACT563N,DW	MC74ACT563N,DW	Octal D-Type Transparent Latch	DIP-20, SO-20
IN74ACT564N,DW	MC74ACT564N,DW	Octal Edge-Triggered Flip-Flop	DIP-20, SO-20
IN74ACT573N,DW	MC74ACT573N,DW	Octal Transparent Latch (3-State)	DIP-20, SO-20
IN74ACT574N,DW	MC74ACT574N,DW	Octal D-Type Flip-Flop, NINV (3-State)	DIP-20, SO-20
IN74ACT620N,DW	MC74ACT620N,DW	Octal Bidirectional Bus Transceiver, INV	DIP-20, SO-20
IN74ACT623N,DW	MC74ACT623N,DW	Octal Bidirectional Bus Transceiver, NINV	DIP-20, SO-20
IN74ACT640N,DW	MC74ACT640N,DW	Octal Bus Transceiver (3-State)	DIP-20, SO-20
IN74ACT643N,DW	MC74ACT643N,DW	Octal Bus Transceiver (3-State)	DIP-20, SO-20
IN74ACT651N,DW	CD74ACT651D	Octal Bus Transceiver/Register, INV (3-State)	DIP-24, SO-24
IN74ACT652N,DW	own	Octal Bus Transceiver/Register, NINV (3-State)	DIP-24, SO-24
IN74ACT810N,D	IN74ACT810D	Quad Exclusive-NOR Gate	DIP-14, SO-14
IN74ACT4006N,D	own	18-Bit Static Shift Register	DIP-14, SO-14
IN74ACT4015N,D	own	Dual 4-Bit Static Shift Register	DIP-16, SO-16
IN74ACT4035N,D	own	4-Bit Parallel-In/Parallel-Out Shift Register	DIP-16, SO-16
IN74ACT4520N,D	own	Dual 4-Bit Synchronous Binary Counter	DIP-16, SO-16

### • IN74VHCXXXD(DW)

Part	Pin to Pin Compatibility	Function	Package
IN74VHC00D	TC74VHC00D	Quad 2-Input NAND Gate	SO-14
IN74VHC02D	TC74VHC02D	Quad 2-Input NOR Gate	SO-14
IN74VHC08D	TC74VHC08D	Hex Inverter, OC	SO-14
IN74VHC32D	TC74VHC32D	Quad 2-Input AND Gate	SO-14
IN74VHC74D	TC74VHC74D	Quad 2-Input OR Gate	SO-14
IN74VHC125D	TC74VHC125D	Quad 3-State Buffer	SO-14
IN74VHC126D	TC74VHC126D	Quad 3-State Buffer	SO-14
IN74VHC240DW	TC74VHC240D	Octal Buffer/Line Driver, INV (3-State)	SO-20
IN74VHC241DW	TC74VHC241D	Octal Buffer/Line Driver, NINV (3-State)	SO-20
IN74VHC244DW	TC74VHC244D	Octal Buffer/Line Driver NINV (3-State)	SO-20
IN74VHC373DW	TC74VHC373D	Octal D-Type Latch (3-State)	SO-20
IN74VHC374DW	TC74VHC374D	Octal D-Type Flip-Flop (3-State)	SO-20

### • IN74VHCTXXXD(DW)

Part	Pin to Pin Compatibility	Function	Package
IN74VHCT00D	TC74VHCT00D	Quad 2-Input NAND Gate	SO-14
IN74VHCT02D	TC74VHCT02D	Quad 2-Input NOR Gate	SO-14
IN74VHCT08D	TC74VHCT08D	Hex Inverter, OC	SO-14
IN74VHCT32D	TC74VHCT32D	Quad 2-Input AND Gate	SO-14
IN74VHCT74D	TC74VHCT74D	Quad 2-Input OR Gate	SO-14
IN74VHCT125D	TC74VHCT125D	Quad 3-State Buffer	SO-14
IN74VHCT126D	TC74VHCT126D	Quad 3-State Buffer	SO-14
IN74VHCT240DW	TC74VHCT240D	Octal Buffer/Line Driver, INV (3-State)	SO-20
IN74VHCT241DW	TC74VHCT241D	Octal Buffer/Line Driver, NINV (3-State)	SO-20
IN74VHCT244DW	TC74VHCT244D	Octal Buffer/Line Driver NINV (3-State)	SO-20
IN74VHCT373DW	TC74VHCT373D	Octal D-Type Latch (3-State)	SO-20
IN74VHCT374DW	TC74VHCT374D	Octal D-Type Flip-Flop (3-State)	SO-20

● **IN74HCXXXAN, D(DW) Series**

Part	Pin to Pin Compatibility	Function	Package
IN74HC00AN,AD	MC74HC00AN,AD	Quad 2-Input NAND Gate	DIP-14, SO-14
IN74HC02AN,AD	MC74HC02AN,AD	Quad 2-Input NOR Gate	DIP-14, SO-14
IN74HC03AN,AD	MC74HC03AN,AD	Quad 2-Input NAND Gate, OC	DIP-14, SO-14
IN74HC04AN,AD	MC74HC04AN,AD	Hex Inverter	DIP-14, SO-14
IN74HC05AN,AD	SN74HC05AN,AD	Hex Inverter, OC	DIP-14, SO-14
IN74HC08AN,AD	MC74HC08AN,AD	Quad 2-Input AND Gate	DIP-14, SO-14
IN74HC10AN,AD	MC74HC10AN,AD	Triple 3-Input NAND Gate	DIP-14, SO-14
IN74HC11AN,AD	MC74HC11AN,AD	Triple 3-Input AND Gate	DIP-14, SO-14
IN74HC14AN,AD	MC74HC14AN,AD	Hex Schmitt-Trigger Inverter	DIP-14, SO-14
IN74HC20AN,AD	MC74HC20AN,AD	Dual 4-Input NAND Gate	DIP-14, SO-14
IN74HC21AN,AD	MC74HC21AN,AD	Dual 4-Input Positive-AND Gate	DIP-14, SO-14
IN74HC22AN,AD	MC74HC22AN,AD	Dual 4-Input Positive-NAND Gate, OC	DIP-14, SO-14
IN74HC27AN,AD	MC74HC27AN,AD	Triple 3-Input Positive-NOR Gate	DIP-14, SO-14
IN74HC30AN,AD	MC74HC30AN,AD	8-Input Positive-NAND Gate	DIP-14, SO-14
IN74HC32AN,AD	MC74HC32AN,AD	Quad 2-Input OR Gate	DIP-14, SO-14
IN74HC74AN,AD	MC74HC74AN,AD	Dual D-Type Flip-Flop	DIP-14, SO-14
IN74HC75AN,AD	MC74HC75AN,AD	Quad Bistable Latch	DIP-16, SO-16
IN74HC85AN,AD	MC74HC85AN,AD	4-Bit Magnitude Comparator	DIP-16, SO-16
IN74HC86AN,AD	MC74HC86AN,AD	Quad 2-Input Exclusive-OR Gate	DIP-14, SO-14
IN74HC109AN,AD	MC74HC109AN,AD	Dual J-K Positive-Edge-Triggered Flip-Flop	DIP-16, SO-16
IN74HC112AN,AD	MC74HC112AN,AD	Dual J-K Negative-Edge-Triggered Flip-Flop	DIP-16, SO-16
IN74HC123AN,AD	MC74HC123AN,AD	Dual Monostable Multivibrator with Reset	DIP-16, SO-16
IN74HC125AN,AD	MC74HC125AN,AD	Quad 3-State Buffer	DIP-14, SO-14
IN74HC132AN,AD	MC74HC132AN,AD	Quad 2-Input NAND Schmitt-Trigger Inverter	DIP-14, SO-14
IN74HC138AN,AD	MC74HC138AN,AD	3-8 Decoder/Demultiplexer	DIP-16, SO-16
IN74HC139AN,AD	MC74HC139AN,AD	Dual 2-4 Decoder/Demultiplexer	DIP-16, SO-16
IN74HC151AN,AD	MC74HC151AN,AD	8-1 Data Selector/Multiplexer	DIP-16, SO-16
IN74HC153AN,AD	MC74HC153AN,AD	Dual 4-1 Data Selector/Multiplexer	DIP-16, SO-16
IN74HC154AN,ADW	MC74HC154AN,ADW	4-16 Decoder/Demultiplexer (3-State)	DIP-24, SO-24
IN74HC155AN,AD	MM74HC155AN,AD	Dual 2-4 Decoder/Demultiplexer	DIP-16, SO-16
IN74HC157AN,AD	MC74HC157AN,AD	Quad 2-1 Data Selector/Multiplexer	DIP-16, SO-16
IN74HC158AN,AD	MC74HC158AN,AD	Quad 2-1 Data Selector/Multiplexer, INV	DIP-16, SO-16
IN74HC161AN,AD	MC74HC161AN,AD	4-Bit Synchronous Binary Counter, Asynchronous Reset	DIP-16, SO-16
IN74HC163AN,AD	MC74HC163AN,AD	4-Bit Synchronous Binary Counter, Synchronous Reset	DIP-16, SO-16
IN74HC164AN,AD	MC74HC164AN,AD	8-Bit Serial-In Parallel-Out Shift Register	DIP-14, SO-14
IN74HC165AN,AD	MC74HC165AN,AD	8-Bit Parallel-in Serial-Out Shift Register	DIP-16, SO-16
IN74HC166AN,AD	CD74HC166AN,AD	8-Bit Parallel-in Serial-Out Shift Register	DIP-16, SO-16
IN74HC174AN,AD	MC74HC174AN,AD	Hex D-Type Flip-Flop	DIP-16, SO-16
IN74HC175AN,AD	MC74HC175AN,AD	Quad D-Type Flip-Flop	DIP-16, SO-16
IN74HC192AN,AD	CD74HC192AN,AD	Synchronous Decade Up/Down Counter	DIP-16, SO-16
IN74HC193AN,AD	CD74HC193AN,AD	4-Bit Synchronous Binary Up/Down Counter	DIP-16, SO-16
IN74HC221AN,AD	CD74HC221AN,AD	Dual Monostable Multivibrator with Reset	DIP-16, SO-16
IN74HC240AN,ADW	MC74HC240AN,ADW	Octal Buffer/Line Driver, INV (3-State)	DIP-20, SO-20
IN74HC241AN,ADW	MC74HC241AN,ADW	Octal Buffer/Line Driver, NINV (3-State)	DIP-20, SO-20
IN74HC244AN,ADW	MC74HC244AN,AD	Octal Buffer/Line Driver NINV (3-State)	DIP-20, SO-20
IN74HC245AN,ADW	MC74HC245AN,AD	Octal Bus Transceiver, NINV (3-State)	DIP-20, SO-20
IN74HC251AN,AD	MC74HC251AN,AD	8-1 Data Selector/Multiplexer (3-State)	DIP-16, SO-16
IN74HC253AN,AD	MC74HC253AN,AD	Dual 4-1 Data Selector/Multiplexer, NINV (3-State)	DIP-16, SO-16
IN74HC257AN,AD	MC74HC257AN,AD	Quad 2-1 Data Selector/Multiplexer, NINV (3-State)	DIP-16, SO-16
IN74HC258AN,AD	CD74HC258AN,AD	Quad 2-1 Data Selector/Multiplexer, INV (3-State)	DIP-16, SO-16
IN74HC273AN,ADW	MC74HC273AN,AD	Octal D-Type Flip-Flop	DIP-20, SO-20
IN74HC279AN,AD	MC74HC279AN,AD	Quad Set/Reset Latch	DIP-16, SO-16
IN74HC283AN,AD	CD74HC283AN,AD	4-Bit Full Adder	DIP-16, SO-16
IN74HC299AN,ADW	MC74HC299AN,AD	8-Bit Universal Shift/Storage Register (3-State)	DIP-20, SO-20
IN74HC323AN,ADW	MC74HC323AN,AD	8-Bit Universal Shift/Storage Register (3-State)	DIP-20, SO-20
IN74HC365AN,AD	MC74HC365AN,AD	Hex Buffer/Line Driver (3-State)	DIP-16, SO-16

# INTEGRATED CIRCUITS

## Standard Digital Logic IC

### ● IN74HCXXXAN, D(DW) Series (continued)

Part	Pin to Pin Compatibility	Function	Package
IN74HC367AN,AD	MC74HC367AN,AD	Hex Buffer/Line Driver (3-State)	DIP-16, SO-16
IN74HC373AN,ADW	MC74HC373AN,AD	Octal D-Type Latch (3-State)	DIP-20, SO-20
IN74HC374AN,ADW	MC74HC374AN,AD	Octal D-Type Flip-Flop (3-State)	DIP-20, SO-20
IN74HC393AN,AD	MC74HC393AN,AD	Dual 4-Bit Binary Counter	DIP-14, SO-14
IN74HC533AN,ADW	MC74HC533AN,AD	Octal D-Type Latch, INV (3-State)	DIP-20, SO-20
IN74HC534AN,ADW	MC74HC534AN,AD	Octal D-Type Flip-Flop, NINV (3-State)	DIP-20, SO-20
IN74HC573AN,ADW	MC74HC573AN,AD	Octal Transparent Latch (3-State)	DIP-20, SO-20
IN74HC574AN,ADW	MC74HC574AN,AD	Octal D-Type Flip-Flop, NINV (3-State)	DIP-20, SO-20
IN74HC595AN,AD	MC74HC595AN,AD	8-Bit Shift Register with Output Latch	DIP-16, SO-16
IN74HC597AN,AD	MC74HC597AN,AD	8-Bit Shift Register with Input Latch	DIP-16, SO-16
IN74HC620AN,ADW	SN74HC620AN,AD	Octal Bidirectional Bus Transceiver, INV	DIP-20, SO-20
IN74HC623AN,ADW	SN74HC623AN,AD	Octal Bidirectional Bus Transceiver, NINV	DIP-20, SO-20
IN74HC640AN,ADW	MC74HC640AN,AD	Octal Bus Transceiver (3-State)	DIP-20, SO-20
IN74HC651AN,ADW	CD74HC651AN,AD	Octal Bus Transceiver/Register (3-State)	DIP-24, SO-24
IN74HC652AN,ADW	CD74HC652AN,AD	Octal Bus Transceiver/Register, NINV (3-State)	DIP-24, SO-24
IN74HC874AN,ADW	own	Dual 4-Bit D-Type Flip Flop	DIP-24, SO-24
IN74HC4015AN,AD	MC74HC4015AN,AD	Dual 4-Bit Static Shift Register	DIP-16, SO-16
IN74HC4046AN,AD	MC74HC4046AN,AD	Phase-Locked Loop	DIP-16, SO-16
IN74HC4051AN,AD	MC74HC4051AN,AD	8-Channel Analog Multiplexer/Demultiplexer	DIP-16, SO-16
IN74HC4052AN,AD	MC74HC4052AN,AD	Dual 4-Channel Analog Multiplexer/Demultiplexer	DIP-16, SO-16
IN74HC4053AN,AD	MC74HC4053AN,AD	Triple 2-Channel Analog Multiplexer/Demultiplexer	DIP-16, SO-16
IN74HC4094AN,AD	CD74HC4094AN,AD	8-Bit Shift and Bus Register	DIP-16, SO-16

### ● IN74HCTXXXAN, D(DW) Series

Part	Pin to Pin Compatibility	Function	Package
IN74HCT00AN,AD	MC74HCT00AN,AD	Quad 2-Input NAND Gate	DIP-14, SO-14
IN74HCT02AN,AD	MC74HCT02AN,AD	Quad 2-Input NOR Gate	DIP-14, SO-14
IN74HCT04AN,AD	MC74HCT04AN,AD	Hex Inverter	DIP-14, SO-14
IN74HCT08AN,AD	MC74HCT08AN,AD	Quad 2-Input AND Gate	DIP-14, SO-14
IN74HCT10AN,AD	MC74HCT10AN,AD	Triple 3-Input NAND Gate	DIP-14, SO-14
IN74HCT14AN,AD	MC74HCT14AN,AD	Hex Schmitt-Trigger Inverter	DIP-14, SO-14
IN74HCT20AN,AD	MC74HCT20AN,AD	Dual 4-Input NAND Gate	DIP-14, SO-14
IN74HCT27AN,AD	MC74HCT27AN,AD	Triple 3-Input Positive-NOR Gate	DIP-14, SO-14
IN74HCT30AN,AD	MC74HCT30AN,AD	8-Input Positive-NAND Gate	DIP-14, SO-14
IN74HCT32AN,AD	MC74HCT32AN,AD	Quad 2-Input OR Gate	DIP-14, SO-14
IN74HCT74AN,AD	MC74HCT74AN,AD	Dual D-Type Flip-Flop	DIP-14, SO-14
IN74HCT85AN,AD	MC74HCT85AN,AD	4-But Magnitude Comparator	DIP-16, SO-16
IN74HCT86AN,AD	MC74HCT86AN,AD	Quad 2-Input Exclusive-OR Gate	DIP-14, SO-14
IN74HCT125AN,AD	MC74HCT125AN,AD	Quad 3-State Buffer	DIP-14, SO-14
IN74HCT126AN,AD	MC74HCT126AN,AD	Quad 3-State Buffer	DIP-14, SO-14
IN74HCT132AN,AD	MC74HCT132AN,AD	Quad 2-Input NAND Schmitt-Trigger Inverter	DIP-14, SO-14
IN74HCT138AN,AD	MC74HCT138AN,AD	3-8 Decoder/Demultiplexer	DIP-16, SO-16
IN74HCT139AN,AD	MC74HCT139AN,AD	Dual 2-4 Decoder/Demultiplexer	DIP-16, SO-16
IN74HCT151AN,AD	MC74HCT151AN,AD	8-1 Data Selector/Multiplexer	DIP-16, SO-16
IN74HCT153AN,AD	MC74HCT153AN,AD	Dual 4-1 Data Selector/Multiplexer	DIP-16, SO-16
IN74HCT155AN,AD	MM74HCT155AN,AD	Dual 2-4 Decoder/Demultiplexer	DIP-16, SO-16
IN74HCT157AN,AD	MC74HCT157AN,AD	Quad 2-1 Data Selector/Multiplexer	DIP-16, SO-16
IN74HCT163AN,AD	MC74HCT163AN,AD	4-Bit Synchronous Binary Counter, Synchronous Reset	DIP-16, SO-16
IN74HCT164AN,AD	MC74HCT164AN,AD	8-Bit Serial-in Parallel-Out Shift Register	DIP-14, SO-14
IN74HCT165AN,AD	MC74HCT165AN,AD	8-Bit Parallel-in Serial-Out Shift Register	DIP-16, SO-16
IN74HCT174AN,AD	MC74HCT174AN,AD	Hex D-Type Flip-Flop	DIP-16, SO-16
IN74HCT240AN,ADW	MC74HCT240AN,AD	Octal Buffer/Line Driver, INV (3-State)	DIP-20, SO-20

● **IN74HCTXXXAN, D(DW) Series** (continued)

Part	Pin to Pin Compatibility	Function	Package
IN74HCT241AN,ADW	MC74HCT241AN,AD	Octal Buffer/Line Driver, NINV (3-State)	DIP-20, SO-20
IN74HCT244AN,ADW	MC74HCT244AN,AD	Octal Buffer/Line Driver NINV (3-State)	DIP-20, SO-20
IN74HCT245AN,ADW	MC74HCT245AN,AD	Octal Bus Transceiver, NINV (3-State)	DIP-20, SO-20
IN74HCT251AN,AD	MC74HCT251AN,AD	8-1 Data Selector/Multiplexer, INV (3-State)	DIP-16, SO-16
IN74HCT273AN,ADW	MC74HCT273AN,AD	Octal D-Type Flip-Flop	DIP-20, SO-20
IN74HCT283AN,AD	CD74HCT283AN,AD	4-Bit Adder	DIP-16, SO-16
IN74HCT299AN,ADW	MC74HCT299AN,AD	8-Bit Universal Shift/Storage Register (3-State)	DIP-20, SO-20
IN74HCT323AN,ADW	MC74HCT323AN,AD	8-Bit Universal Shift/Storage Register (3-State)	DIP-20, SO-20
IN74HCT373AN,ADW	MC74HCT373AN,AD	Octal D-Type Latch (3-State)	DIP-20, SO-20
IN74HCT374AN,ADW	MC74HCT374AN,AD	Octal D-Type Flip-Flop (3-State)	DIP-20, SO-20
IN74HCT573AN,ADW	MC74HCT573AN,AD	Octal Transparent Latch (3-State)	DIP-20, SO-20
IN74HCT574AN,ADW	MC74HCT574AN,AD	Octal D-Type Flip-Flop, NINV (3-State)	DIP-20, SO-20
IN74HCT620AN,ADW	SN74HCT620AN,AD	Octal Bidirectional Bus Transceiver, INV	DIP-20, SO-20
IN74HCT623AN,ADW	own	Octal Bidirectional Bus Transceiver, NINV	DIP-20, SO-20
IN74HCT640AN,ADW	own	Octal Bus Transceiver (3-State)	DIP-20, SO-20
IN74HCT874AN,ADW	MC74HCT874AN,AD	Dual 4-Bit D-Type Flip-Flop	DIP-24, SO-24

● **IN74LVXXN, D(DW) Series**

Part	Pin to Pin Compatibility	Function	Package
IN74LV00N,D	74LV00N,D	Quad 2-Input NAND Gate	DIP-14, SO-14
IN74LV02N,D	74LV02N,D	Quad 2-Input NOR Gate	DIP-14, SO-14
IN74LV04N,D	74LV04N,D	Hex Inverter	DIP-14, SO-14
IN74LVU04N,D	74LVU04N,D	Hex Inverter	DIP-14, SO-14
IN74LV08N,D	74LV08N,D	Quad 2-Input AND Gate	DIP-14, SO-14
IN74LV14N,D	74LV14N,D	Hex Schmitt-Trigger Inverter	DIP-14, SO-14
IN74LV32N,D	74LV32N,D	Quad 2-Input OR Gate	DIP-14, SO-14
IN74LV74N,D	74LV74N,D	Dual D-Type Flip-Flop	DIP-14, SO-14
IN74LV86N,D	74LV86N,D	Quad 2-Input Exclusive-OR Gate	DIP-14, SO-14
IN74LV138N,D	74LV138N,D	3-8 Decoder/Demultiplexer	DIP-16, SO-16
IN74LV139N,D	74LV139N,D	Dual 2-4 Decoder/Demultiplexer	DIP-16, SO-16
IN74LV164N,D	74LV164N,D	8-Bit Serial-In Parallel-Out Shift Register	DIP-14, SO-14
IN74LV174N,D	74LV174N,D	Hex D-Type Flip-Flop	DIP-16, SO-16
IN74LV240N,DW	74LV240N,D	Octal Buffer/line Driver, INV (3-State)	DIP-20, SO-20
IN74LV241N,DW	74LV241N,D	Octal Buffer/Line Driver, NINV (3-State)	DIP-20, SO-20
IN74LV244N,DW	74LV244N,D	Octal Buffer/Line Driver, NINV (3-State)	DIP-20, SO-20
IN74LV245N,DW	74LV245N,D	Octal Bus Transceiver, NINV (3-State)	DIP-20, SO-20
IN74LV273N,DW	74LV273N,D	Octal D-Type Flip-Flop	DIP-20, SO-20
IN74LV373N,DW	74LV373N,D	Octal D-Type Latch (3-State)	DIP-20, SO-20
IN74LV374N,DW	74LV374N,D	Octal D-Type Flip-Flop (3-State)	DIP-20, SO-20
IN74LV573N,DW	74LV573N,D	Octal Transparent Latch (3-State)	DIP-20, SO-20
IN74LV574N,DW	74LV574N,D	Octal D-Type Flip-Flop, NINV (3-State)	DIP-20, SO-20
IN74LV620N,DW	74LV620N,D	Octal Bidirectional Bus Transceiver, INV	DIP-20, SO-20
IN74LV623N,DW	74LV623N,D	Octal Bidirectional Bus Transceiver, NINV	DIP-20, SO-20
IN74LV640N,DW	74LV640N,D	Octal Bus Transceiver (3-State)	DIP-20, SO-20

# INTEGRATED CIRCUITS

## Standard Digital Logic IC

### • IN74XXXN, D Series

Part	Pin to Pin Compatibility	Function	Package
IN7401N	SN7401N	Quad 2-Input NAND Gate, OC	DIP-14
IN7406N,D	SN7406N,D	Hex Inverter/Buffer with High-Voltage Output, OC	DIP-14, SO-14
IN7420N	SN7420N	Dual 4-Input NAND Gate	DIP-14
IN7450N	SN7450N	Dual 2-Wide 2-Input AND-OR-Invert Gate	DIP-14
IN7472N	SN7472N	J-K Flip-Flop	DIP-14
IN74141N	SN74141N	BCD-to-Decimal Decoder/Driver	DIP-16
IN74145N	SN74145N	BCD-to-Decimal Decoder, OC	DIP-16
IN74154N	SN74154N	4-16 Decoder/Demultiplexer	DIP-24
IN74175N	SN74175N	Quad D-Type Flip-Flop	DIP-16

### • IN74LSXXXN, D(DW) Series

Part	Pin to Pin Compatibility	Function	Package
IN74LS04N,D	CD74LS04N,D	Hex Inverter	DIP-14, SO-14
IN74LS05N,D	CD74LS05N,D	Hex Inverter, OC	DIP-14, SO-14
IN74LS06N,D	CD74LS06N,D	Hex Inverter/Buffer with High-Voltage Output, OC	DIP-14, SO-14
IN74LS07N,D	CD74LS07N,D	Hex Buffer with High-Voltage Output, OC, 30 V	DIP-14, SO-14
IN74LS14N,D	CD74LS14N,D	Hex Schmitt-Trigger Inverter	DIP-14, SO-14
IN74LS86N,D	CD74LS86N,D	Quad 2-Input Exclusive-OR Gate	DIP-14, SO-14
IN74LS138N,D	CD74LS138N,D	3-8 Decoder/Demultiplexer	DIP-16, SO-16
IN74LS157N,D	CD74LS157N,D	Quad 2-1 Data Selector/Multiplexer	DIP-16, SO-16
IN74LS161AN,AD	CD74LS161AN,AD	4-Bit Binary Counter	DIP-16, SO-16
IN74LS164N,D	CD74LS164N,D	8-Bit Parallel-Out Shift Register	DIP-14, SO-14
IN74LS244N,DW	CD74LS244N,DW	Octal Buffer/Line Driver, NINV (3-State)	DIP-20, SO-20
IN74LS245N,DW	CD74LS245N,DW	Octal Bus Transceiver, NINV (3-State)	DIP-20, SO-20

### • IN74ALSXXXXN, D(DW) Series

Part	Pin to Pin Compatibility	Function	Package
IN74ALS00AN,AD	SN74ALS00AN,AD	Quad 2-Input Positive-NAND Gate	DIP-14, SO-14
IN74ALS01N,D	SN74ALS01N,D	Quad 2-Input Positive-NAND Gate, OC	DIP-14, SO-14
IN74ALS02N,D	SN74ALS02N,D	Quad 2-Input Positive-NOR Gate	DIP-14, SO-14
IN74ALS03AN,AD	SN74ALS03AN,AD	Quad 2-Input Positive-NAND Gate, OC	DIP-14, SO-14
IN74ALS04AN,AD	SN74ALS04AN,AD	Hex Inverter	DIP-14, SO-14
IN74ALS05AN,AD	SN74ALS05AN,AD	Hex Inverter, OC	DIP-14, SO-14
IN74ALS08N,D	SN74ALS08N,D	Quad 2-Input Positive-AND Gate	DIP-14, SO-14
IN74ALS09N,D	SN74ALS09N,D	Quad 2-Input Positive-AND Gate, OC	DIP-14, SO-14
IN74ALS10AN,AD	SN74ALS10AN,AD	Triple 3-Input Positive-NAND Gate	DIP-14, SO-14
IN74ALS11AN,AD	SN74ALS11AN,AD	Triple 3-Input Positive-AND Gate	DIP-14, SO-14
IN74ALS12AN,AD	SN74ALS12AN,AD	Triple 3-Input Positive-NAND Gate, OC	DIP-14, SO-14
IN74ALS14N,D	SN74ALS14N,D	Hex Schmitt-Trigger Inverter	DIP-14, SO-14
IN74ALS15AN,AD	SN74ALS15AN,AD	Triple 3-Input Positive-AND Gate, OC	DIP-14, SO-14
IN74ALS20AN,AD	SN74ALS20AN,AD	Dual 4-Input Positive-NAND Gate	DIP-14, SO-14
IN74ALS21N,AD	SN74ALS21N,AD	Dual 4-Input Positive-AND Gate	DIP-14, SO-14
IN74ALS22BN,BD	SN74ALS22BN,BD	Dual 4-Input Positive-NAND Gate, OC	DIP-14, SO-14
IN74ALS27N,D	SN74ALS27N,D	Triple 3-Input Positive-NOR Gate	DIP-14, SO-14
IN74ALS30AN,AD	SN74ALS30AN,AD	8-Input Positive-NAND Gate	DIP-14, SO-14
IN74ALS32N,D	SN74ALS32N,D	Quad 2-Input Positive-OR Gate	DIP-14, SO-14
IN74ALS33AN,AD	SN74ALS33AN,AD	Quad 2-Input Positive-NOR Buffer, OC	DIP-14, SO-14

● **IN74ALSXXXN, D(DW) Series** (continued)

Part	Pin to Pin Compatibility	Function	Package
IN74ALS51N,D	SN74ALS51N,D	AND-OR-Invert Gate	DIP-14, SO-14
IN74ALS54N,D	SN74ALS54N,D	4-Wide AND-OR-Invert Gate	DIP-14, SO-14
IN74ALS55N,D	SN74ALS55N,D	2-Wide 4-Input AND-OR-Invert Gate	DIP-14, SO-14
IN74ALS74AN,AD	SN74ALS74AN,AD	Dual D-Type Flip-Flop	DIP-14, SO-14
IN74ALS75N,D	SN74ALS75N,D	Quad Bistable Latch	DIP-16, SO-16
IN74ALS85N,D	SN74ALS85N,D	4-Bit Magnitude Comparator	DIP-16, SO-16
IN74ALS86N,D	SN74ALS86N,D	Quad 2-Input Exclusive-OR Gate	DIP-14, SO-14
IN74ALS90N,D	SN74ALS90N,D	4-Bit Decade Counter	DIP-14, SO-14
IN74ALS93N,D	SN74ALS93N,D	4-Bit Binary Counter	DIP-14, SO-14
IN74ALS107N,D	SN74ALS107N,D	Dual J-K Flip-Flop with Clear	DIP-14, SO-14
IN74ALS109N,D	SN74ALS109N,D	Dual J-K Positive-Edge-Triggered Flip-Flop	DIP-16, SO-16
IN74ALS112AN,AD	SN74ALS112AN,AD	Dual J-K Negative-Edge-Triggered Flip-Flop	DIP-16, SO-16
IN74ALS113AN,AD	SN74ALS113AN,AD	Dual J-K Negative-Edge-Triggered Flip-Flop	DIP-14, SO-14
IN74ALS114AN,AD	SN74ALS114AN,AD	Dual J-K Negative-Edge-Triggered Flip-Flop	DIP-14, SO-14
IN74ALS123N,D	SN74ALS123N,D	Dual Monostable Multivibrator with Reset	DIP-16, SO-16
IN74ALS125N,D	SN74ALS125N,D	Quad 3-State Buffer	DIP-14, SO-14
IN74ALS136N,D	SN74ALS136N,D	Quad 2-Input Exclusive-OR Gate, OC	DIP-14, SO-14
IN74ALS138N,D	SN74ALS138N,D	3-8 Decoder/Demultiplexer	DIP-16, SO-16
IN74ALS139N,D	SN74ALS139N,D	Dual 2-4 Decoder/Demultiplexer	DIP-16, SO-16
IN74ALS151N,D	SN74ALS151N,D	8-1 Data Selector/Multiplexer	DIP-16, SO-16
IN74ALS153N,D	SN74ALS153N,D	Dual 4-1 Data Selector/Multiplexer	DIP-16, SO-16
IN74ALS154N,DW	SN74ALS154N,D	4-16 Decoder/Demultiplexer (3-State)	DIP-24, SO-24
IN74ALS155N,D	SN74ALS155N,D	Dual 2-4 Decoder/Demultiplexer	DIP-16, SO-16
IN74ALS157N,D	SN74ALS157N,D	Quad 2-1 Data Selector/Multiplexer	DIP-16, SO-16
IN74ALS158N,D	SN74ALS158N,D	Quad 2-1 Data Selector/Multiplexer, INV	DIP-16, SO-16
IN74ALS160AN,AD	SN74ALS160AN,AD	Synchronous Decade Counter, Asynchronous Reset	DIP-16, SO-16
IN74ALS161AN,AD	SN74ALS161AN,AD	4-Bit Synchronous Binary Counter, Asynchronous Reset	DIP-16, SO-16
IN74ALS162AN,AD	SN74ALS162AN,AD	Synchronous Decade Counter, Synchronous Reset	DIP-16, SO-16
IN74ALS163AN,AD	SN74ALS163AN,AD	4-Bit Synchronous Binary Counter, Synchronous Reset	DIP-16, SO-16
IN74ALS164N,D	SN74ALS164N,D	8-Bit Serial-In Parallel-Out Shift Register	DIP-14, SO-14
IN74ALS165N,D	SN74ALS165N,D	8-Bit Parallel-in Serial-Out Shift Register	DIP-16, SO-16
IN74ALS166N,D	SN74ALS166N,D	8-Bit Parallel-in Serial-Out Shift Register	DIP-16, SO-16
IN74ALS170N,D	SN74ALS170N,D	4-by-4 Register File, OC	DIP-16, SO-16
IN74ALS173AN,AD	SN74ALS173AN,AD	4-Bit D-Type Register (3-State)	DIP-16, SO-16
IN74ALS174N,D	SN74ALS174N,D	Hex D-Type Flip-Flop	DIP-16, SO-16
IN74ALS175N,D	SN74ALS175N,D	Quad D-Type Flip-Flop	DIP-16, SO-16
IN74ALS181N,DW	SN74ALS181N,D	4-Bit Arithmetic Logic Unit	DIP-24, SO-24
IN74ALS182N,D	SN74ALS182N,D	Look-Ahead Carry Generator	DIP-16, SO-16
IN74ALS190N,D	SN74ALS190N,D	Synchronous Decade Up/Down Counter	DIP-16, SO-16
IN74ALS191N,D	SN74ALS191N,D	4-Bit Synchronous Binary Up/Down Counter	DIP-16, SO-16
IN74ALS192N,D	SN74ALS192N,D	Synchronous Decade Up/Down Counter	DIP-16, SO-16
IN74ALS193N,D	SN74ALS193N,D	4-Bit Synchronous Binary Up/Down Counter	DIP-16, SO-16
IN74ALS240AN,ADW	SN74ALS240AN,AD	Octal Buffer/Line Driver, INV (3-State)	DIP-20, SO-20
IN74ALS241AN,ADW	SN74ALS241AN,AD	Octal Buffer/Line Driver, NINV (3-State)	DIP-20, SO-20
IN74ALS242AN,AD	SN74ALS242AN,AD	Quad Bus Transceiver, INV (3-State)	DIP-14, SO-14
IN74ALS243AN,AD	SN74ALS243AN,AD	Quad Bus Transceiver, NINV (3-State)	DIP-14, SO-14
IN74ALS244AN,ADW	SN74ALS244AN,AD	Octal Buffer/Line Driver, NINV (3-State)	DIP-20, SO-20
IN74ALS245AN,ADW	SN74ALS245AN,AD	Octal Bus Transceiver, NINV (3-State)	DIP-20, SO-20
IN74ALS251N,D	SN74ALS251N,D	8-1 Data Selector/Multiplexer, INV (3-State)	DIP-16, SO-16
IN74ALS253N,D	SN74ALS253N,D	Dual 4-1 Data Selector/Multiplexer, NINV (3-State)	DIP-16, SO-16
IN74ALS257AN,AD	SN74ALS257AN,AD	Quad 2-1 Data Selector/Multiplexer, NINV (3-State)	DIP-16, SO-16
IN74ALS258AN,AD	SN74ALS258AN,AD	Quad 2-1 Data Selector/Multiplexer, INV (3-State)	DIP-16, SO-16
IN74ALS259N,D	SN74ALS259N,D	8-Bit Addressable Latch	DIP-16, SO-16
IN74ALS273N,DW	SN74ALS273N,D	Octal D-Type Flip-Flop	DIP-20, SO-20
IN74ALS279N,D	SN74ALS279N,D	Quad Set/Reset Latch	DIP-16, SO-16
IN74ALS280N,D	SN74ALS280N,D	9-Bit Odd/Even Parity Generator/Checker	DIP-14, SO-14

# INTEGRATED CIRCUITS

## Standard Digital Logic IC

### • IN74ALSXXXXN, D(DW) Series (continued)

Part	Pin to Pin Compatibility	Function	Package
IN74ALS295BN,BD	SN74ALS295BN,BD	4-Bit Universal Shift Register	DIP-14, SO-14
IN74ALS298N,D	SN74ALS298N,D	Quad 2-1 Data Selector/Multiplexer	DIP-16, SO-16
IN74ALS299N,DW	SN74ALS299N,D	8-Bit Universal Shift/Storage Register (3-State)	DIP-20, SO-20
IN74ALS323N,DW	SN74ALS323N,D	8-Bit Universal Shift/Storage Register (3-State)	DIP-20, SO-20
IN74ALS352N,D	SN74ALS352N,D	Dual 4-1 Data Selector/Multiplexer	DIP-16, SO-16
IN74ALS353N,D	SN74ALS353N,D	Dual 4-1 Data Selector/Multiplexer (3-State)	DIP-16, SO-16
IN74ALS368N,D	SN74ALS368N,D	Hex Bus Driver (3-State)	DIP-16, SO-16
IN74ALS373N,DW	SN74ALS373N,D	Octal D-Type Latch (3-State)	DIP-20, SO-20
IN74ALS374AN,ADW	SN74ALS374AN,AD	Octal D-Type Flip-Flop (3-State)	DIP-20, SO-20
IN74ALS377AN,ADW	SN74ALS377AN,AD	Octal D-Type Flip-Flop with Enable	DIP-20, SO-20
IN74ALS393N,D	SN74ALS393N,D	Dual 4-Bit Binary Counter	DIP-14, SO-14
IN74ALS465AN,ADW	SN74ALS465AN,AD	Octal Buffer, NINV (3-State)	DIP-20, SO-20
IN74ALS466AN,ADW	SN74ALS466AN,AD	Octal Buffer, INV (3-State)	DIP-20, SO-20
IN74ALS573N,DW	SN74ALS573N,D	Octal Transparent Latch (3-State)	DIP-20, SO-20
IN74ALS574N,DW	SN74ALS574N,D	Octal D-Type Flip-Flop (3-State)	DIP-20, SO-20
IN74ALS640BN,BDW	SN74ALS640BN,BD	Octal Bus Transceiver (3-State)	DIP-20, SO-20
IN74ALS643AN,ADW	SN74ALS643AN,AD	Octal Bus Transceiver (3-State)	DIP-20, SO-20
IN74ALS670N,D	SN74ALS670N,D	4-by-4 Register File (3-State)	DIP-16, SO-16
IN74ALS873N,DW	SN74ALS873N,D	Dual 4-Bit D-Type Latch (3-State)	DIP-24, SO-24
IN74ALS874N,DW	SN74ALS874N,D	Dual 4-Bit D-Type Flip-Flop	DIP-24, SO-24
IN74ALS1000AN,AD	SN74ALS1000AN,AD	Quad 2-Input Positive-NAND Buffer	DIP-14, SO-14
IN74ALS1002AN,AD	SN74ALS1002AN,AD	Quad 2-Input Positive-NOR Buffer	DIP-14, SO-14
IN74ALS1003AN,AD	SN74ALS1003AN,AD	Quad 2-Input Positive-NAND Buffer, OC	DIP-14, SO-14
IN74ALS1004N,D	SN74ALS1004N,D	Hex Inverting Driver	DIP-14, SO-14
IN74ALS1005N,D	SN74ALS1005N,D	Hex Inverting Buffer, OC	DIP-14, SO-14
IN74ALS1008AN,AD	SN74ALS1008AN,AD	Quad 2-Input Positive-NAND Buffer	DIP-14, SO-14
IN74ALS1010AN,AD	SN74ALS1010AN,AD	Triple 3-Input Positive-NAND Buffer	DIP-14, SO-14
IN74ALS1011AN,AD	SN74ALS1011AN,AD	Triple 3-Input Positive-AND Buffer	DIP-14, SO-14
IN74ALS1020AN,AD	SN74ALS1020AN,AD	Dual 4-Input Positive-NAND Buffer	DIP-14, SO-14
IN74ALS1032AN,AD	SN74ALS1032AN,AD	Quad 2-Input Positive-OR Buffer/Driver	DIP-14, SO-14
IN74ALS1034N,D	SN74ALS1034N,D	Hex Driver	DIP-14, SO-14
IN74ALS1035N,D	SN74ALS1035N,D	Hex Noninverting Buffer, OC	DIP-14, SO-14

## • FUNCTIONAL SELECTION

### GATES

Function	Part	Technology										Pins	
		74AC	74ACT	74VHC	74VHCT	74HC	74HCT	74LV	74	74LS	74ALS		
<b>Positive-NAND Gates</b>													
8-Input	30					x	x					x	14
Dual 4-Input	20	x	x			x	x		x			x	14
	40												14
	1020											x	14
Triple 3-Input	10	x	x			x	x					x	14
	1010											x	14
Quad 2-Input	00	x	x	x	x	x	x	x				x	14
	132	x	x			x	x					x	14
	1000											x	14
<b>Positive-NAND Gates, OC</b>													
Dual 4-Input	22					x	x					x	14
Triple 3-Input	12											x	14
Quad 2-Input	01								x			x	14
	03					x						x	14
	1003											x	14
<b>Positive-AND Gates, OC</b>													
Triple 3-Input	15											x	14
Quad 2-Input	09											x	14
<b>Positive-AND Gates</b>													
Dual 4-Input	21	x	x			x	x					x	14
Triple 3-Input	11	x	x			x						x	14
	1011											x	14
Quad 2-Input	08	x	x	x	x	x	x	x				x	14
	1008											x	14
<b>Positive-OR Gates</b>													
Quad 2-Input	32	x	x	x	x	x	x	x				x	14
	1032											x	14
<b>Positive-NOR Gates</b>													
Triple 3-Input	27	x	x			x	x					x	14
Quad 2-Input	02	x	x	x	x	x	x	x				x	14
	33											x	14
	1002											x	14
<b>Exclusive-OR Gates</b>													
Quad 2-Input	86	x	x	x	x	x	x	x			x	x	14
	810	x	x										14
Quad 2-Input, OC	136											x	14
<b>AND-OR Gates</b>													
2-Wide 4-Input	55											x	14
4-Wide 2-3-3-2 Input	54											x	14
Dual 2-Wide 2-Input	51											x	14
<b>Expandable Gates</b>													
Dual 2-Wide AND-OR-Invert	50									x			14
4-Wide AND-OR-Invert	53												14
Dual 4-Input Expander	60												14

# INTEGRATED CIRCUITS

## Standard Digital Logic IC

### ● FUNCTIONAL SELECTION (continued)

#### HEX INVERTERS/NONINVERTERS

Function	Part	Technology										Pins	
		74AC	74ACT	74VHC	74VHCT	74HC	74HCT	74LV	74	74LS	74ALS		
Hex Inverters	04	x	x			x	x	x			x	x	14
	U04							x					14
	05	x	x			x					x	x	14
	06								x		x		14
	14	x	x			x	x	x			x	x	14
	16												14
	1004											x	14
1005											x	14	
Hex Noninverters	34	x	x										14

#### DRIVERS AND BUS TRANSCEIVERS

Function	Part	Technology										Pins	
		74AC	74ACT	74VHC	74VHCT	74HC	74HCT	74LV	74	74LS	74ALS		
<b>Hex Drivers</b>													
Hex Drivers	07										x		14
	1034											x	14
	1035											x	14
Noninverting Hex Buffers/Drivers	365					x							16
	367					x							16
	368											x	16
<b>Drivers with 3-State Outputs</b>													
Quad Buffer Drivers	125	x	x	x	x	x	x					x	14
	126			x	x		x						14
Octal Buffer/Drivers, NINV	241	x	x	x	x	x	x	x				x	20
	244	x	x	x	x	x	x	x			x	x	20
	465											x	20
Octal Buffer Drivers, INV	240	x	x	x	x	x	x	x				x	20
	466											x	20
<b>Bus Transceivers with 3-State Outputs</b>													
Quad Transceiver, NINV	243											x	14
Quad Transceiver, INV	242											x	14
Octal Transceiver	245	x	x			x	x	x			x	x	20
	620	x	x			x	x	x					20
	640	x	x			x	x	x				x	20
	643	x	x									x	20
Octal Bus Transceivers with Registers	651	x	x			x							24
	652	x	x			x							24
True Output Transceiver	623	x	x			x	x	x					20
<b>50/75-Ohm Line Drivers</b>													
Quad 2-Input Positive-NOR	128												14

**• FUNCTIONAL SELECTION** (continued)

**FLIP-FLOPS**

Function	Part	Technology										Pins
		74AC	74ACT	74VHC	74VHCT	74HC	74HCT	74LV	74	74LS	74ALS	
<b>Dual and Single Flip-Flops</b>												
Single J-K	72								x			14
Dual J-K Edge-Triggered	107										x	14
	109	x	x			x					x	16
	112	x	x			x					x	16
	113										x	14
	114										x	14
Dual D-Type	74	x	x	x	x	x	x	x			x	14
<b>Quad and Hex Flip-Flops</b>												
Quad D-Type	175	x	x			x			x		x	16
Hex D-Type	174	x	x			x	x	x			x	16
Quad J-K	279					x	x				x	16
<b>D-Type Flip-Flops</b>												
Octal (3-State)	374	x	x	x	x	x	x	x			x	20
	574	x	x			x	x	x			x	20
Octal with Clear	273	x	x			x	x	x			x	20
Dual 4-Bit with Clear	874					x	x				x	24
Octal with Enable	377										x	20
Octal Inverting (3-State)	534	x	x			x						20
	564	x	x									

**LATCHES AND MULTIVIBRATORS**

Function	Part	Technology										Pins
		74AC	74ACT	74VHC	74VHCT	74HC	74HCT	74LV	74	74LS	74ALS	
<b>Latches</b>												
4-Bit Bistable	75					x					x	16
Quad Set/Reset	279					x	x				x	16
Transparent (3-State)	373	x	x	x	x	x	x	x			x	20
	573	x	x			x	x	x			x	20
Dual 4-Bit Transparent (3-State)	873										x	24
Inverting Transparent	533	x	x			x						20
	563	x	x									20
8-Bit Addressable	259										x	16
<b>Multivibrators</b>												
Dual Monostable with Clear	123					x					x	16
	221					x						20

# INTEGRATED CIRCUITS

## Standard Digital Logic IC

### ● FUNCTIONAL SELECTION (continued)

#### REGISTERS

Function	Part	Technology										Pins
		74AC	74ACT	74VHC	74VHCT	74HC	74HCT	74LV	74	74LS	74ALS	
<b>Shift Registers</b>												
8-Bit Universal	198											24
	299	x	x			x	x				x	20
	323	x	x			x	x				x	20
4-Bit Parallel-in/ Parallel-out	295										x	14
	4035	x	x									16
8-Bit Serial-in Parallel-Out	164	x	x			x	x	x		x	x	14
8-Bit Parallel-in Serial-Out	165					x	x				x	16
	166					x					x	16
Dual 4-Bit Static	4015	x	x			x						16
8-Bit Shift and Store	4094					x						16
	4006	x	x									14
<b>Shift Registers with Latches</b>												
Serial-in Parallel-Out with Output Latches	595					x						16
Parallel-in Serial-Out with Input Latches	597					x						16
<b>Register Files</b>												
4-by-4, OC (3-State)	170										x	16
	670										x	16
<b>Other Registers</b>												
4-Bit D-Type Register (3-State)	173										x	16

#### COUNTERS

Function	Part	Technology										Pins
		74AC	74ACT	74VHC	74VHCT	74HC	74HCT	74LV	74	74LS	74ALS	
<b>Synchronous Counters</b>												
4-Bit Decade, Asynchronous Reset	160										x	16
	162										x	16
Decade Up/Down	190										x	16
	192	x	x			x					x	16
4-Bit Binary, Asynchronous Reset	161	x	x			x				x	x	16
	163	x	x			x	x				x	16
4-Bit Binary Up/Down	191										x	16
	193	x	x			x					x	16
<b>Asynchronous Counters</b>												
4-Bit Decade	90										x	14
4-Bit Binary	93										x	14
Dual 4-Bit Binary	393					x					x	14
	4520	x	x									16

● **FUNCTIONAL SELECTION** (continued)

**DECODERS, DATA SELECTORS/MULTIPLEXERS**

Function	Part	Technology										Pins	
		74AC	74ACT	74VHC	74VHCT	74HC	74HCT	74LV	74	74LS	74ALS		
<b>Data Selectors/Multiplexers</b>													
Quad 2-1	157	x	x			x	x				x	x	16
	158	x	x			x						x	16
	298											x	16
	257	x	x			x						x	16
	258	x	x			x						x	16
Dual 4-1	153	x	x			x	x					x	16
	253	x	x			x						x	16
	352											x	16
	353											x	16
8-1	151	x	x			x	x					x	16
	152												14
	251	x	x			x	x					x	16
16-1	150												24
<b>Analog Multiplexers/Demultiplexers</b>													
8-Channel	4051					x							16
Dual 4-Channel	4052					x							16
Triple 2-Channel	4053					x							16
<b>Decoders</b>													
Dual 2-4	139	x	x			x	x	x				x	16
	155					x	x					x	16
3-8	138	x	x			x	x	x			x	x	16
4-16	154					x				x		x	24
BCD-to-Decimal	141									x			16
	145									x			16
<b>Digital Loops</b>													
Phase-Lock Loop	4046					x							16

**COMPARATORS AND ERROR DETECTION CIRCUITS**

Function	Part	Technology										Pins	
		74AC	74ACT	74VHC	74VHCT	74HC	74HCT	74LV	74	74LS	74ALS		
<b>Comparators</b>													
4-Bit Magnitude Comparator	85					x	x					x	16
<b>Parity Generators/Checkers</b>													
8-Bit Odd/Even Parity	180												14
9-Bit Odd/Even Parity	280											x	14

**ARITHMETIC CIRCUITS**

Function	Part	Technology										Pins	
		74AC	74ACT	74VHC	74VHCT	74HC	74HCT	74LV	74	74LS	74ALS		
4-Bit Arithmetic Logic Unit	181											x	24
Look-Ahead Carry Generator	182											x	16
4-Bit Full Adder	283					x	x						16

**• FAMILY CHARACTERISTICS**

**DC Characteristics (Max)**

Parameters	TTL			CMOS										Units
	74	74LS	74ALS	4000A	4000B	74AC	74ACT	74VHC	74VHCT	74HC	74HCT	74LV		
Supply Voltage Range, $V_{CC}(V_{DD})$	5±5%	5±10%	5±10%	3...15	3...18	2...6	5±10%	2...5.5	5±5%	2...6	5±10%	1.0...5.5	V	
Operating Temperature, $T_A$	-10...+70	0...+70	-10...+70	-45...+85	-55...+125	-45...+85	-45...+85	-40...+85	-40...+85	-55...+125	-55...+125	-40...+125	°C	
High -Level Input Voltage, $V_{IH}$ (min)	2	2	2	0.8xV <sub>DD</sub>	0.7xV <sub>DD</sub>	0.7xV <sub>CC</sub>	2	0.7xV <sub>CC</sub>	2	0.7xV <sub>CC</sub>	2	0.7xV <sub>CC</sub>	V	
Low -Level Input Voltage, $V_{IL}$ (max)	0.8	0.8	0.8	0.2xV <sub>DD</sub>	0.3xV <sub>DD</sub>	0.3xV <sub>CC</sub>	0.8	0.3xV <sub>CC</sub>	0.8	0.3xV <sub>CC</sub>	0.8	0.3xV <sub>CC</sub>	V	
High-Level Output Voltage, $V_{OH}$ (min)	2.4	V <sub>CC</sub> -2	V <sub>CC</sub> -2	V <sub>DD</sub> -1	V <sub>DD</sub> -0.05	V <sub>CC</sub> -0.1	V <sub>CC</sub> -0.1	3.8	3.8	V <sub>CC</sub> -0.1	V <sub>CC</sub> -0.1	V <sub>CC</sub> -0.2	V	
Low-Level Output Voltage, $V_{OL}$ (max)	0.4	0.5	0.5	0.05	0.05	0.1	0.1	0.44	0.44	0.1	0.1	0.2	V	
High-Level Input Current, $I_{IH}$	40	20	20	+1	+0.3	+1	+1	+1	+1	+1	+1	+1	µA	
Low-Level Input Current, $I_{IL}$	-1600	-400	-100	-1	-0.3	-1	-1	-1	-1	-1	-1	-1	µA	
High-Level Output Current, $I_{OH}$	-0.4	-0.4	-0.4	-0.25 at $V_O=4.5 V$ $V_{DD}=5.0 V$	-4.2 at $V_O=2.5 V$ $V_{DD}=5.0 V$	-24 at $V_O=V_{CC}-0.8$	-24 at $V_O=V_{CC}-0.8$	-8	-8	-4 at $V_O=V_{CC}-0.8$	-4 at $V_O=V_{CC}-0.8$	-16	mA	
Low-Level Output Current, $I_{OL}$	16	8	8	0.5 at $V_O=0.5 V$ $V_{DD}=5.0 V$	0.88 at $V_O=0.4 V$ $V_{DD}=5.0 V$	24 at $V_O=0.4 V$	24 at $V_O=0.4 V$	8	8	4 at $V_O=0.4 V$	4 at $V_O=0.4 V$	16	mA	
DC Noise Margin, DCM	0.4/0.4	0.3/0.7	0.3/0.7	1.0 at $V_{DD}=5 V$ 1.0 at $V_{DD}=10 V$	1.5 at $V_{DD}=5 V$ 3.0 at $V_{DD}=10 V$ 4.0 at $V_{DD}=15 V$	1.25/1.25	0.7/2.4	1.25/1.25	0.7/2.4	1.25/1.25	0.7/2.4	0.8/0.8	V	

● **FAMILY CHARACTERISTICS**

**DC Characteristics (Type)**

Parameters	TTL			CMOS							Units		
	74	74LS	74ALS	4000A	4000B	74AC	74ACT	74VHC	74VHCT	74HC		74HCT	74LV
Supply Current for Gate, $I_G$	3.4	0.4	0.2	0.0004	0.0001	0.0005	0.0005	0.0005	0.0005	0.0005	0.0005	0.0005	mA
Power Supply for Gate, $P_G$	10	2	1	0.0025	0.0001	0.0025	0.0025	0.0025	0.0025	0.001	0.001	0.001	mW
Propagation Delay Time, $T_P$	10	7	5	40 at $V_{DD}=5V$ 20 at $V_{DD}=10V$	40 at $V_{DD}=5V$ 20 at $V_{DD}=10V$ 15 at $V_{DD}=15V$	5	5	5.3	5.5	8	8	10	ns
Clock Frequency, $F_{max}$	35 $C_L=15$ pF	40 $C_L=15$ pF	45 $C_L=50$ pF	5 at $V_{DD}=5V$ 10 at $V_{DD}=10V$ $C_L=15$ pF	5 at $V_{DD}=5V$ 10 at $V_{DD}=10V$ 14 at $V_{DD}=15V$ $C_L=50$ pF	140 $C_L=50$ pF	140 $C_L=50$ pF	115 $C_L=50$ pF 170 $C_L=15$ pF	140 $C_L=50$ pF 160 $C_L=15$ pF	30 $C_L=50$ pF	30 $C_L=50$ pF	40 $C_L=50$ pF	MHz
Inputs $V_{IL}/V_{IH}$	TTL	TTL	TTL	CMOS	CMOS	CMOS	TTL, CMOS	TTL at $V_O=3.3V$ , CMOS	TTL, CMOS	CMOS	TTL, CMOS	CMOS	-
Outputs $V_{OL}/V_{OH}$	TTL	TTL	TTL	TTL, CMOS	TTL, CMOS	TTL, CMOS	TTL, CMOS	TTL, CMOS	TTL	TTL, CMOS	TTL, CMOS	TTL, CMOS	-

**● FAMILY CHARACTERISTICS**

**AC Characteristics**

Parameters	Performance	TTL			CMOS							Units		
		7400	74LS00	74ALS00	4001A	4001B	74AC00	74ACT00	74VHC00	74VHCT00	74HC00		74HCT00	74LV00
Propagation Delay, $t_{PHL}/t_{PHL}$ Gate, NOR or NAND	Type	10 $C_L=15$ pF	7 $C_L=15$ pF	5 $C_L=50$ pF	80 at $V_{DD}=5$ V 40 at $V_{DD}=10$ V $C_L=15$ pF	60 at $V_{DD}=5$ V 25 at $V_{DD}=10$ V 20 at $V_{DD}=15$ V $C_L=50$ pF	5 $C_L=50$ pF	5 $C_L=50$ pF	5.4 $C_L=50$ pF 3.9 $C_L=15$ pF	5.9 $C_L=50$ pF 5.4 $C_L=15$ pF	8 $C_L=50$ pF	8 $C_L=50$ pF	10 $C_L=50$ pF	ns
	Max	22 $C_L=15$ pF	15 $C_L=15$ pF	11 $C_L=50$ pF	120 at $V_{DD}=5$ V 60 at $V_{DD}=10$ V 48 at $V_{DD}=15$ V $C_L=15$ pF	110 at $V_{DD}=5$ V 60 at $V_{DD}=10$ V 48 at $V_{DD}=15$ V $C_L=50$ pF	8.5 $C_L=50$ pF	9.5 $C_L=50$ pF	8.5 $C_L=50$ pF 6.5 $C_L=15$ pF	8.5 $C_L=50$ pF 7.5 $C_L=15$ pF	22 $C_L=50$ pF	28 $C_L=50$ pF	14 $C_L=50$ pF	ns
Propagation Delay, $t_{PHL}/t_{PHL}$ (Clock to Q) Counter	Type	16 $C_L=15$ pF	18 $C_L=15$ pF	10 $C_L=50$ pF	450 at $V_{DD}=5$ V 150 at $V_{DD}=10$ V $C_L=15$ pF	180 at $V_{DD}=5$ V 80 at $V_{DD}=10$ V 65 at $V_{DD}=15$ V $C_L=50$ pF	5 $C_L=50$ pF	6 $C_L=50$ pF	6 $C_L=50$ pF 4.9 $C_L=15$ pF	8.5 $C_L=50$ pF 7.7 $C_L=15$ pF	20 $C_L=50$ pF	20 $C_L=50$ pF	18 $C_L=50$ pF	sn
	Max	38 $C_L=15$ pF	27 $C_L=15$ pF	26 $C_L=50$ pF	650 at $V_{DD}=5$ V 250 at $V_{DD}=10$ V $C_L=15$ pF	360 at $V_{DD}=5$ V 160 at $V_{DD}=10$ V 130 at $V_{DD}=15$ V $C_L=50$ pF	9.5 $C_L=50$ pF	12 $C_L=50$ pF	10.5 $C_L=50$ pF 8.5 $C_L=15$ pF	14.5 $C_L=50$ pF 13.5 $C_L=15$ pF	28 $C_L=50$ pF	28 $C_L=50$ pF	23 $C_L=50$ pF	ns
Propagation Delay, $t_{PHL}/t_{PHL}$ (Clock to Q) Flip-Flop, D-Type	Type	25 $C_L=15$ pF	25 $C_L=1$ 5pF	13 $C_L=50$ pF	150 at $V_{DD}=5$ V 75 at $V_{DD}=10$ V $C_L=15$ pF	150 at $V_{DD}=5$ V 65 at $V_{DD}=10$ V 45 at $V_{DD}=15$ V $C_L=50$ pF	6 $C_L=50$ pF	6 $C_L=50$ pF	6.1 $C_L=50$ pF 4.6 $C_L=15$ pF	6.3 $C_L=50$ pF 5.8 $C_L=15$ pF	20 $C_L=50$ pF	24 $C_L=50$ pF	25 $C_L=50$ pF	ns
	Max	40 $C_L=15$ pF	40 $C_L=15$ pF	18 $C_L=50$ pF	400 at $V_{DD}=5$ V 150 at $V_{DD}=10$ V $C_L=15$ pF	300 at $V_{DD}=5$ V 130 at $V_{DD}=10$ V 90 at $V_{DD}=15$ V $C_L=50$ pF	10 $C_L=50$ pF	11.5 $C_L=50$ pF	10.5 $C_L=50$ pF 8.5 $C_L=15$ pF	10.0 $C_L=50$ pF 9.0 $C_L=15$ pF	30 $C_L=50$ pF	36 $C_L=50$ pF	35 $C_L=50$ pF	ns

• **CMOS IC for LCD Wrist-Watches and Clocks**

Part (Pin to Pin Compatibility)	Display			Functions				Multi- plexing Ratio	Supply Current without Load max, μA	V <sub>DD</sub> , V	Notes
	Digits	Flags	Marks	Hour Minute Second Month Date	Alarm	Chrono- graph	12H/ 24H				
<b>Digital watch</b>											
IZ6099F/ L/C/E (KS5199)	3.5		1	+			12	1/2	1.5	1.5	
IZ6099K	3.5		1	+			12/24		1.5	1.5	
IZ6199	3.5		1	+			12	1/2	1.5	3.0	IZ6099+EL
IZ6095C	4		5	+	+		12/24	1/2	2.0	1.5	
IZ6090F/ G/ L	6	7	4	+	+	1/100	12/24	1/2	2.0	1.5	
IZ6090S	6	7	4	+	+	1/100	12/24	1/2	2.0	1.5	ON/OFF LCD
IZ6090H	6	7	4	+	+	1/100	12/24	1/2	2.0	3.0	
IZ6094	10		6	+	+	+	12/24	1/4	2.5	3.0	
IZ6092	12		6	+	+	+	12/24	1/3	2.5	1.5	
IZ6093 / L	12		6	+	+	+	12/24	1/3	2.5	3.0	
IZ6193	12		6	+	+	+	12/24	1/3	2.5	3.0	IZ6093+EL
IZ6597/B	12		6	+	+	+	12/24	1/3	2.5	3.0	Built-in high-voltage driver EL of illumination
IZ6018	12	-	8	+	+	+	12/24	1/3	2.0	3.0	°C: -20÷+60 °F: -4÷+140
IZ6006	3.5			m,s				1/2	3.0	1.5	Count down/up timer
IZ7007	7		5	+			12	1/2	3.0	1.5	Step counter with watch
IZ7010	7		5	+			24	1/2	3.0	1.5	For electron pedometer- ergmeter with functions watch and alarm
IC6101	12		5	+		+	24	1/2	3.0	1.5	Touch-tone signal Automatic accuracy adjusting Dual Time Daylight saving time Three independent timers

# INTEGRATED CIRCUITS

## Clock/Watch IC

### • CMOS IC for LCD Wrist-Watches and Clocks (continued)

Part (Pin to Pin Compatibility)	Display			Functions				Multi- plexing Ratio	Supply Current without Load max, $\mu\text{A}$	$V_{\text{DD}}$ , V	Notes
	Digits	Flags	Marks	Hour Minute Second Month Date	Alarm	Chrono- graph	12H/ 24H				
<b>Analog - Digital watch</b>											
IZ6490	8		8	+	+	1/100	12/24	1/3	1.5	3.0	Calendar adjusts automatically for odd and even months
IZ6491	8		8	+	+	1/100	12/24	1/3	1.5	1.5	
<b>Analog watch and clock</b>											
IZ6013 (KS5113)				h,m,s			12	1/6	2.5	1.5	LCD watch with long second hand
<b>Analog clock</b>											
IZ33173	Output pulse duration 31.25 ms								2.0	1.5	Clock IC
IZ33263									2.0	1.5	Clock with alarm function
IZ33567									1.5	1.5	Clock with alarm, snooze, crescendo
<b>LED watch</b>											
IZ8560	4		5	h, m	+		12/24		5.0	-14...-6.5	
<b>Watch with Vacuum – Luminescent Display</b>											
IZ9012	4		10	+	-		24			5.0	

• **Electronic Thermometer IC**

Part	Pin to Pin Compatibility	Function	Features	Pads
IZ8016		100° Digital thermometer °C/°F	<ul style="list-style-type: none"> <li>□ Measurement temperature range: from -50°C to +50°C (from -58°F to +122°F)</li> <li>□ Resolution: 0.2°C (°F)</li> <li>□ Accuracy: ±1°C (°F)</li> <li>□ Supply voltage 1.5V</li> <li>□ Measurement cycle 1, 3, 5 &amp; 10 seconds (on default– 10 seconds)</li> <li>□ Measuring RC-oscillator with external resistor &amp; capacitor</li> <li>□ 32 kHz clock RC-oscillator with build-in capacity</li> <li>□ Serial interface</li> <li>□ Build-in circuit of non-linear digital correction</li> <li>□ 3.5 digit LCD with double multiplex</li> </ul>	36
IZ8005	HT7501	Medical thermometer	<ul style="list-style-type: none"> <li>□ Supply voltage 1.5V</li> <li>□ Measurement temperature range: from +32.00°C to+43.00°C</li> <li>□ Accuracy: ±0.1°C</li> <li>□ Resolution: 0.01°C</li> <li>□ Selftesting</li> <li>□ Alarm signal</li> <li>□ Storage of measurements results (highest temperature)</li> <li>□ Automatic switch-off after 8 min 40 sec</li> <li>□ One button on/off switching</li> </ul>	37
IZ8071		Digital thermometer	<ul style="list-style-type: none"> <li>□ Measurement temperature range: from 32 to 42°C (from 89.6 to 107.6°F)</li> <li>□ Measurement accuracy ±0.05°C – for range from 35 to 38°C, ±0.1°C – for ranges from 32 to 35°C &amp; from 38°C to 42°C</li> <li>□ Resolution: 0.0025°C</li> <li>□ RC-oscillator with own frequency 32.32kHz (external resistance) with adjustment function</li> <li>□ Build-in LCD driver circuit 3COM x 11SEG, 1/3 duty, 1/2 bias</li> </ul>	42
IN18B20** IN18B20D	DS18B20	Integrated circuit of digital sensor-measurer of temperature for industrial temperature range	<ul style="list-style-type: none"> <li>□ Measurement temperature range: from -55°C to +125°C</li> <li>□ Temperature value is converted to 12-bit digital code</li> <li>□ Accuracy of temperature indication can be programmed by customer form 9 to 12 bit</li> <li>□ Alarm signal for case of temperature excess of threshold values determined (programmed) by customer</li> <li>□ Unique 64-bit serial number for each IC, not available for changes by customer</li> <li>□ Data read/write operation from memory of IC, 1-wire interface of data transfer</li> </ul>	SO-8 TO-92

\*\* Under Development

# DISCRETE SEMICONDUCTORS

## Transistors, Diodes, Diode Arrays

### • Power N-Channel MOSFETs

Part	Function	Package
IFP50N06	N-Channel MOSFET 60 V; 0.022 $\Omega$ - 50 A	TO-220/3
IFP70N06	N-Channel MOSFET 60 V; 0.015 $\Omega$ - 70 A	TO-220/3
IFP85N06	N-Channel MOSFET 60 V; 0.012 $\Omega$ - 85 A	TO-220/3
IFP75N75	N-Channel MOSFET 75 V; 0.017 $\Omega$ - 75 A	TO-220/3
IFP75N08	N-Channel MOSFET 80 V; 0.015 $\Omega$ - 75 A	TO-220/3
IFP630	N-Channel MOSFET 200 V; 0.400 $\Omega$ - 9 A	TO-220/3
IFF630		TO-220FP
IFP640	N-Channel MOSFET 200 V; 0.180 $\Omega$ - 18 A	TO-220/3
IFF640		TO-220FP
IFP634	N-Channel MOSFET 250 V; 0.450 $\Omega$ - 8 A	TO-220/3
IFF634		TO-220FP
IFP730	N-Channel MOSFET 400 V; 0.950 $\Omega$ - 6 A	TO-220/3
IFF730		TO-220FP
IFP740	N-Channel MOSFET 400 V; 0.550 $\Omega$ - 10 A	TO-220/3
IFF740		TO-220FP
IFP830	N-Channel MOSFET 500 V; 1.400 $\Omega$ - 5 A	TO-220/3
IFF830		TO-220FP
IFP840	N-Channel MOSFET 500 V; 0.850 $\Omega$ - 8 A	TO-220/3
IFF840		TO-220FP
IFP13N50	N-Channel MOSFET 500 V; 0.490 $\Omega$ - 13 A	TO-220/3
IFW20N50	N-Channel MOSFET 500 V; 0.260 $\Omega$ - 20 A	TO-247
IFL50N50	N-Channel MOSFET 500 V; 0.120 $\Omega$ - 50 A	TO-265
IFP1N60	N-Channel MOSFET 600 V; 12.000 $\Omega$ - 1 A	TO-220/3
IFU1N60		TO-251
IFD1N60		TO-252
IFU2N60	N-Channel MOSFET 600 V; 5.0 $\Omega$ - 2 A	TO-251
IFD2N60		TO-252
IFP2N60	N-Channel MOSFET 600 V; 5.0 $\Omega$ - 2 A	TO-220/3
IFF2N60		TO-220FP
IFP4N60	N-Channel MOSFET 600 V; 2.5 $\Omega$ - 4.0 A	TO-220/3
IFF4N60		TO-220FP
IFP7N60	N-Channel MOSFET 600 V; 1.2 $\Omega$ - 7 A	TO-220/3
IFF7N60		TO-220FP
IFP10N60	N-Channel MOSFET 600 V; 0.8 $\Omega$ - 10 A	TO-220/3
IFF10N60		TO-220FP
IFP12N60	N-Channel MOSFET 600 V; 0.7 $\Omega$ - 12 A	TO-220/3
IFF12N60		TO-220FP
IFW20N60	N-Channel MOSFET 600 V; 0.32 $\Omega$ - 20 A	TO-247
IFW24N60	N-Channel MOSFET 600 V; 0.26 $\Omega$ - 24 A	TO-247
IFW28N60	N-Channel MOSFET 600 V; 0.24 $\Omega$ - 28 A	TO-247
IFL40N60	N-Channel MOSFET 600 V; 0.16 $\Omega$ - 40 A	TO-263
IFU1N65	N-Channel MOSFET 650 V; 13.0 $\Omega$ - 1 A	TO-251
IFD1N65		TO-252
IFU2N65		TO-251
IFD2N65	N-Channel MOSFET 650 V; 5.5 $\Omega$ - 2 A	TO-252
IFP2N65		TO-220/3
IFF2N65	TO-220FP	
IFP4N65	N-Channel MOSFET 650 V; 2.7 $\Omega$ - 4 A	TO-220/3
IFF4N65		TO-220FP
IFP7N65	N-Channel MOSFET 650 V; 1.3 $\Omega$ - 7 A	TO-220/3
IFF7N65		TO-220FP
IFP10N65	N-Channel MOSFET 650 V; 0.85 $\Omega$ - 10 A	TO-220/3
IFF10N65		TO-220FP
IFF12N65	N-Channel MOSFET 650 V; 0.8 $\Omega$ - 12 A	TO-220/3
IFF12N65		TO-220FP

• **Power N-Channel MOSFETs** (continued)

Part	Function	Package
IFP1N80	N-Channel MOSFET 800 V; 18.0 Ω- 1 A	TO-220/3
IFU1N80		TO-251
IFF3N80	N-Channel MOSFET 800 V; 5.0 Ω- 3 A	TO-220FP
IFW10N80	N-Channel MOSFET 800 V; 1.1 Ω- 10 A	TO-247
IFW9N90	N-Channel MOSFET 900 V; 1.4 Ω- 9 A	TO-247
IFW11N90	N-Channel MOSFET 900 V; 1.1 Ω- 11 A	TO-247
IWP5NK80	N-Channel MOSFET 800 V; 2.4 Ω- 4.3 A	TO-220/3
IZ024N	N-Channel MOSFET 55 V; 0.075 Ω- 17 A	Chip

• **Fast (Ultrafast) Rectifying Diode (FRD, UFRD)**

Part	Pin to Pin Compatibility	Peak. Rectified Direct current $I_{R,MAX}$ (A)	Non repetitive Peak Surge Current $I_{p, max}$ (A)	Max Reverse Voltage $U_{REV,MAX}$ (V)	Max.Reverse Recovery Time $t_{REC}$ ns	Max. instantaneous forward voltage $U_R$ V	Max. instantaneous reverse current (T=25°C) $I_{REV, mA}$	Package
IWR0520F	MUR0520F	5	35	200	250	1.1	50	TO-220
IWR0520U	MUR0520U	5	35	200	25	1.2	50	TO-220

• **Photo-diode**

Part	Pin to Pin Compatibility	Function	Package
IWPH01-02A	S2506-02	Photo-diode	Special 2-pin package

• **Power Zener Diodes**

Part	Pin to Pin Compatibility	Function	Package
IZ3527	MR2537L	Power limiting diode for rectifying bridges of alternator plant $I_{RECT}=35A$ ; $U_{BR}=18-23V$	DO-21 TO-220
IZ3549	MR2535L	Power limiting diode for rectifying bridges of alternator plant $I_{RECT}=35A$ ; $U_{BR}=36-46V$	DO-21 TO-220
IZ3563	MR2563L	Power limiting diode for rectifying bridges of alternator plant $I_{RECT}=35A$ ; $U_{BR}=50-60V$	DO-21 TO-220

• **Fast (Ultrafast) Rectifying Diode Arrays (FRDA, UFRDA)**

Part	Pin to Pin Compatibility	Peak. Rectified Direct current $I_{R,MAX}$ (A)	Non repetitive Peak Surge Current $I_{p, max}$ (A)	Max Reverse Voltage. $U_{REV,MAX}$ (V)	Max.Reverse Recovery Time $t_{REC}$ ns	Max. instantaneous forward voltage $U_R$ V	Max. instantaneous reverse current (T=25°C) $I_{REV, mA}$	Package
IWR0520FM	MUR0520FM	5	35	200	250	1.1	50	TO-220
IWR0520UM	MUR0520UM	5	35	200	25	1.2	50	TO-220
IWR0540UM	MUR0540UM	5	35	400	60	1.4	50	TO-220
IW0140A4	MU0140A4	1		400	60	1.4	50	TO-220

# SYSTEMS OF INFORMATION DISPLAY

## Liquid Crystal Display

### • BASIC SPECIFICATION

№	Item	Climatic performance group <sup>(*)</sup>			Note
		I	II	III	
1	Operation temperature range, °C	-40...+85	-20...+70	-0...+50	(*)
2	Contrast	6 : 1	6 : 1	6 : 1	
3	Viewing angle, degrees (at contrast: ≥ 2): - on a vertical; - on a horizontal	-30...+50 -50...+30 ± 45	-30...+50 -50...+30 ± 45	-30...+50 -50...+30 ± 45	(*)
4	AC applied voltage, V	3 ± 10% 5 ± 10%	3 ± 10% 5 ± 10%	3 ± 10%	
5	Display type	Positive mode	Reflective Transflective Transmissive	Reflective Transflective Transmissive	(*)
		Negative mode	Transmissive	Transmissive	
6	Viewing angle	6 o'clock, 7:30 o'clock, 12 o'clock and other			(*)
7	Storage temperature range, °C	-60...+85	-50...+80	-50...+60	(*)

(\*) Climatic performance group, optical mode and maximal contrast angle depend on customer's requirements.  
 (\*) Vertical field-of-vision angle depends on maximal contrast angle.

### • LCD TYPE: REFLECTIVE/ TRANSFLECTIVE/ TRANSMISSIVE

### • LCD MODE: POSITIVE/ NEGATIVE

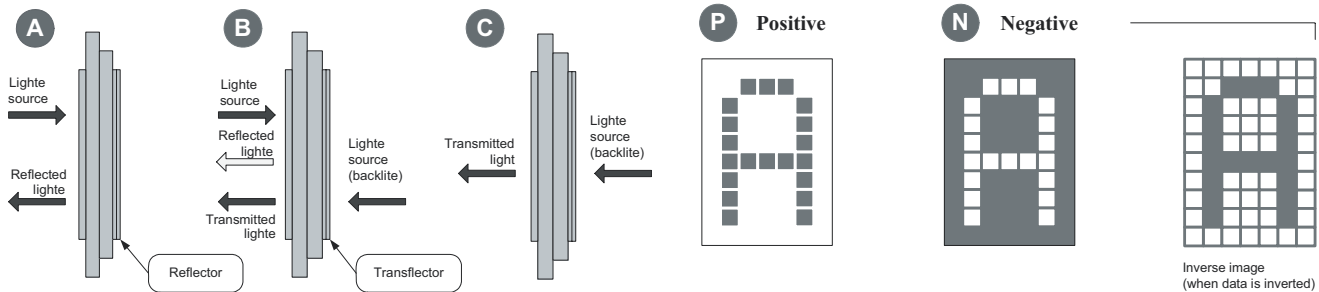

A. Reflective LCD	B. Transflective LCD	C. Transmissive LCD
Reflector bonded to the rear polarizer reflects the incoming ambient light. <i>Low power consumption because no backlight is required.</i>	Transflector bonded to the rear polarizer reflects light from front as well as enabling lights to pass through the back . <i>Used with backlight off in bright light and with it on in low light to reduce power consumption.</i>	Whithout reflector or transflector bonded to the rear polarizer. Backlight required . <i>Most common is transmissive negative image.</i>

### • LCD: System of Designations

Samples of marking:

<input type="checkbox"/> in catalog	<b>ID-10DP41-MI</b>
<input type="checkbox"/> during shipments (*)	<b>ID-10DP41-MI-AP1-2.54</b>
<b>ID - 10 DP 1 - M - A P 1 - 2.54</b>	
<b>1 2 3 4 5 7 8 9 10</b>	

(\*) Optical mode, LCD type, maximal contrast angle and climatic performance group shall be agreed upon during LCD shipments.

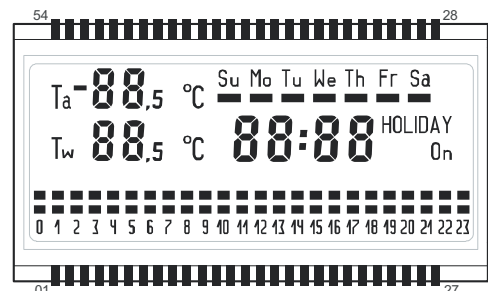

## LCD marking system at INTEGRAL JSC

Decoding according to the positions numbers

<b>№</b>	<b>Description</b>	<b>Application</b>	<b>Samples</b>
<b>1</b>	<i>Marking for LCD of INTEGRAL JSC</i>	For all type LCD	<b>ID</b>
<b>2</b>	<b>LCD characteristic</b>	For all type LCD	
	Number of digits	LCD of <b>D</b> and <b>DP</b> type	<b>8</b>
	Number of chars in a line, number of lines	LCD of <b>C</b> and <b>CP</b> type	<b>1602</b> - 2 lines till 16 chars
	Number of segment (column), number of common (row) lines	LCD of <b>G</b> and <b>GP</b> type	<b>12064</b> - 120 SEG, 64 COM
	Total number of LCD segments	LCD of <b>P</b> type	<b>8</b>
<b>3</b>	<b>Category of the LCD:</b> <b>D</b> – Digital <b>C</b> – Characters <b>G</b> – Graphic (dot matrix) <b>P</b> – contains pictogram (icon)	LCD of <b>D</b> type LCD of <b>C</b> type LCD of <b>G</b> type LCD of <b>P</b> type	<b>D, DP</b> <b>C, CP</b> <b>G, GP</b> <b>P</b>
<b>4</b>	<b>Design number for a certain type of LCD</b>	For all type LCD	<b>45</b>
<b>5</b>	<b>Method of LCD mounting on PCB</b> <b>M</b> – using metal pins <b>R</b> – using conductive rubber (zebra) or conductive anisotropic glue	For all type LCD	<b>M</b> <b>R</b>
<b>6</b>	<b>LCD type:</b> <b>A</b> – reflective LCD <b>B</b> – transfective LCD <b>C</b> – transmissive LCD	For all type LCD during shipments (*)	<b>A</b> <b>B</b> <b>C</b>
<b>7</b>	<b>Optical mode:</b> <b>N</b> – Negative LCD <b>P</b> – Positive LCD	For all type LCD during shipments (*)	<b>N</b> <b>P</b>
<b>8</b>	<b>Operation temperature range:</b> <b>1</b> - temperature - 40...+ 85 °C <b>2</b> - temperature - 20...+ 70 °C <b>3</b> - temperature 0...+ 50 °C <b>4</b> - other	For all type LCD during shipments (*)	<b>1</b> <b>2</b> <b>3</b> <b>4</b>
<b>9</b>	<b>Pitch on metal pins, mm</b>	For all type LCD during shipments (*)	<b>1.27</b> <b>1.80</b> <b>2.00</b> <b>2.54</b>

(\*) Optical mode, LCD type, maximal contrast angle and climatic performance group shall be agreed upon during LCD shipments.

## Foundry business

- Semiconductor IC and Discrete Devices Manufacturing under the Customer's Design (delivery on base of Probe Test)
- Semiconductor IC and Discrete Devices Manufacturing under the Customer's Design (delivery on the base of PCM)
- Wafer Fab Service – execution of separate Process Flow Steps or blocks (Metal sputtering, film deposition, EPI growing, back grinding, wafers testing and so on)
- Raw Si substrate and EPI manufacturing under the Customer's Spec

### Production Capacity available for Foundry Business:

- 8" wafer production line (0.5-0.35 $\mu$ m design rule)
- 6" wafer production line (0.8-1.2  $\mu$ m design rule)
- 4" wafer production line (1.2-3.0  $\mu$ m design rule)

### Basic Process available:

#### a) Integrated Circuits:

- DMOS
- CMOS
- BiCMOS
- CDMOS
- BiCDMOS
- Bipolar

#### b) Discrete devices:

- D-MOS ( $\leq 1000$  V)
- Multi-Epi ( $\leq 700$  V)
- Bipolar
- Process for high frequency devices ( $\leq 300$  V)

### Si substrates and EPI, manufacturing and delivery (according to the Customer's Spec):

- 3", 4", 6", 8" wafers
- EPI parameter range:  $d=0.5\dots 80$   $\mu$ m,  $\rho=0.1\dots 50$   $\Omega \cdot$  cm

### Mask making:

- Mask Set manufacturing under the Customer's Spec (GDS II and DB):
  - a) for contact lithography
  - b) for Projection Reduction (Stepper lithography) (1:1/1:5/1:10)
- Pellicles manufacturing under the Customer's Spec
- Manufacture of photomasks with P/R coatings (glass and quartz substrates)

## Contract management

### Packaging:

- IC and Discrete Devices assembly (packaging) with Testing
- IC and Discrete Devices assembly (packaging) without Testing
- IC and Discrete Devices assembly (packaging) with Testing and Marking

### Packages Types available:

#### a) Integrated Circuits:

- SOP (8-28 LD)
- DIP (8-40 LD)
- SHRINK DIP (30, 42, 52, 56 LD)
- QFP (48, 64, 100 LD)
- SIL (3, 8, 13, 17 LD)
- SIP (9LD)
- TO -220 (3, 5, 7 LD)
- SOT -23, SOT -143, SOT -223

#### b) Discrete devices:

- Case 22A-01
- DO-34, DO-35
- MELF, miniMELF
- SOT -23, SOT -143, SOT -223
- ISOWATT
- TO-18, TO-39, TO-72, TO-92, TO-126,
- TO-218, TO-220
- KD-17
- DPAK, D2PAK

## Fabless service

### IC and discrete devices design:

- IC Design according to the Customer's Data Sheet (Spec) and Process Development
- Discrete Devices Design according to the Customer's Data Sheet (Spec) and Process development
- GDS II and Tape out
- Engineering Consulting service
- Reengineering

## Supplementary services

### Design of electronic devices/ instruments and manufacture of samples as per Customer's requirements:

- Design and manufacture of PCB
- Design and manufacture of LCD:
  - TN-type ("twist") for electronic clock/watch, calculators, etc,
  - STN-type ("supertwist") for general purposes

### Other services:

- Design and manufacture of quartz tooling and accessories, tools
- Design and manufacture of molds, punches, casting/transfer molds
- Marking blocks manufacturing
- High-precision stamping of lead frames for IC manufacturing

• **Base Technology Process** (short form output characteristics)

Process name	Process Description	Application, electrical, parameters
<b>Bipolar processes for digital-to-analogue IC</b>		
CMOS, 20 V, with p-n junction isolation  «Bp30C-20»	Photomasks, pcs. 12-14 Mean design rule, $\mu\text{m}$ 2.0 EPI WAFER: Epi layer: Phos/ N-type/ Thk 8/ Res 1.5; Buried layers: Sb/N-type/Thk 6.0/Res 20; Boron/P-type/Thk 1.95/Res210 Substrate: Boron/ P-type/ Thk 460/ Res 10/ Orientation (111) Isolation: p-n junction p-base depth, $\mu\text{m}$ 2.0 N+emitter depth, $\mu\text{m}$ 1.7 Emitter size, $\mu\text{m}$ 7*7 Distance between transistors, $\mu\text{m}$ 4 Switching: contacts 1, $\mu\text{m}$ 3*3 pitch Me 1, $\mu\text{m}$ 9.0 contacts 2, $\mu\text{m}$ 4*4 pitch Me 2, $\mu\text{m}$ 12.0	Small and medium-scale integration digital-analogue IC, $V_{DD} < 18\text{ V}$  NPN Vertical: $\beta_n=150\text{ Uce}=27\text{ V}$ PNP Lateral: $\beta_p=30\text{ Uce}=35\text{ V}$ PNP Vertical: $\beta_p=45\text{ Uce}=35\text{ V}$ PNP Vertical with isolated collector: $\beta_p=80\text{ Uce}=30\text{ V}$ Capacitors: emitter-base; collector-base; Me-n+; Me1-Me2. Resistors in layers: Isolation; Base; Resistor
40 V, with p-n junction isolation  «Bp30-40»	Photomasks, pcs. 8-13 Mean design rule, $\mu\text{m}$ 2.0 EPI WAFER: Epi layer: Phos/ N-type/Thk 13/ Res 3.5; Buried layers: Sb/N-type/Thk 6.0/Res20; Boron/P-type/Thk 1.95/Res210 Substrate: Boron/P-type/Thk 460/Res 10/Orientation(111) p-n junction p-base depth, $\mu\text{m}$ 2.0 N+emitter depth, $\mu\text{m}$ 1.7 Emitter size, $\mu\text{m}$ 9*9 Distance between transistors, $\mu\text{m}$ 4 Switching: contacts 1, $\mu\text{m}$ 3*3 pitch Me 1, $\mu\text{m}$ 9.0 contacts 2, $\mu\text{m}$ 4*4 pitch Me 2, $\mu\text{m}$ 14.0	Small -scale integration digital-analogue IC, $V_{DD} < 40\text{ V}$  NPN Vertical: $\beta_n =150\text{ Uce}=48\text{ V}$ PNP Lateral: $\beta_p =65\text{ Uce}=60\text{ V}$ PNP Vertical: $\beta_p =60\text{ Uce}=60\text{ V}$ Capacitors: emitter-base; collector-base; Me-n+; Me1-Me2. Resistors in layers: Isolation; Base; Resistor. PolySi
5 V, «Isoplanar – 1»  «Bpl-30-5»	Photomasks, pcs. 15 Mean design rule, $\mu\text{m}$ 3.0 EPI WAFER: Epi: Phos/N-type/Thk 1.5/Res 0.3; Buried layers: Sb/N-type/Thk 2.5/Res 35; Boron/P-type/Thk 1.95/Res210 Substrate: Boron/P-type/Thk 460/Res 12/Orientation (100) Isolation: LOCOS + p <sup>+</sup> - guard rings p-base depth, $\mu\text{m}$ 0.854 N+ emitter depth, $\mu\text{m}$ 0.55 Emitter size, $\mu\text{m}$ 2*3 Distance between transistors, $\mu\text{m}$ 2 Switching: contacts1, $\mu\text{m}$ 2*3 pitch Me 1, $\mu\text{m}$ 6.5 contacts 2, $\mu\text{m}$ 4*4 pitch Me 2, $\mu\text{m}$ 10.0	Small and medium-scale integration digital-analogue IC, $V_{DD} < 5\text{ V}$  NPN Vertical: $\beta_p =100\text{ Uce}= 8\text{ BV}$ PNP Lateral: $\beta_p =25\text{ Uce}=20\text{ V}$  Resistors in layer: Base

# FOUNDRIY BUSINESS

## Base Technology Process

### • Base Technology Process (continued)

Process name	Process Description	Application, electrical parameters
CMOS, 12 V, with LOCOS and p-n junction isolation  «Bp-20Y-12»	Photomasks, pcs. 18 Mean design rule, $\mu\text{m}$ 2.5 EPI WAFER: Epi: Phos/N-type/Thk 4.0/Res 1.0; Buried layers: Sb/N-type/Thk 2.5/Res 35; Boron/P-type/Thk 2.0/Res550 Substrate: Boron/P-type/Thk 460/Res 12/Orientation (100)  Isolation: LOCOS + p <sup>+</sup> - guard rings p-base depth, $\mu\text{m}$ 1.2 N-base depth, $\mu\text{m}$ 1.5 N+emitter depth, $\mu\text{m}$ 0.9 Emitter size, $\mu\text{m}$ 2*3 Distance between transistors, $\mu\text{m}$ 3 Switching: contacts 1, $\mu\text{m}$ 2*3 pitch Me 1, $\mu\text{m}$ 8.0 contacts 2, $\mu\text{m}$ 3*3 pitch Me 2, $\mu\text{m}$ 10.0	Medium-scale integration digital-analogue IC, $V_{DD} < 15\text{ V}$  NPN Vertical: $\beta_p = 80$ $U_{ce} = 18\text{ V}$ PNP Vertical: $\beta_p = 60$ $U_{ce} = 18\text{ V}$ Capacitors: Poly-SiO <sub>2</sub> (250Å)-Sin+ Resistors in layer: Base, Resistor
<b>CMOS</b>		
5 V, 1.5 $\mu\text{m}$ CMOS, 1 Poly, 2 Me  «CMOS15AC»	Photomasks, pcs. 14 Design rules, $\mu\text{m}$ 1.5 Substrate: s/N-type/Res 4.5 N/P-well depth, $\mu\text{m}$ 5/5 Interlayer dielectric: BPSG Interlevel dielectric: PEoxide Gate SiO <sub>2</sub> , Å 245 Channel length: NMOS/PMOS, $\mu\text{m}$ 1.4/2.0 N LDD- drains space line Poly, $\mu\text{m}$ 3.4 contacts 1, $\mu\text{m}$ 1.5*4.5 space line Me 1, $\mu\text{m}$ 6.0 contacts 2, $\mu\text{m}$ 3.0*4.5 space line Me 2, $\mu\text{m}$ 9.5	Small and medium-scale integration logic IC, $V_{DD} < 5\text{ V}$  NMOS: $V_{tn} = 0.8\text{ V}$ , $U_{sd} > 12\text{ V}$ PMOS: $V_{tp} = -0.8\text{ V}$ , $U_{sd} > 12\text{ V}$
5 V, 1.5 $\mu\text{m}$ CMOS, local n <sup>+</sup> , p <sup>+</sup> - buried layers 1 Poly, 1 Me, specifically resistant  «CMOS15VY»	Photomasks, pcs. 14 Design rules, $\mu\text{m}$ 1.5 Substrate: Boron/P-type/Res 12 N <sup>+</sup> /P <sup>+</sup> -buried layers, $\mu\text{m}$ Epi layer Phos/N-type/Thk 8/Res 4.5 N/P-well depth, $\mu\text{m}$ 6/7 Gate SiO <sub>2</sub> , Å 245 Interlayer dielectric BPSG Channel length (active): NMOS/PMOS, $\mu\text{m}$ 2.0/2.0 Channel length (output): NMOS/PMOS, $\mu\text{m}$ 2,4/2,4 space line Poly, $\mu\text{m}$ 4,5 contacts, $\mu\text{m}$ 1.5*4.5 space line Me, $\mu\text{m}$ 6	Small and medium-scale integration logic IC, $V_{DD} < 5\text{ V}$ , with $V_{in}/V_{out}$ overvoltage $< 10\text{ V}$ , specifically resistant  NMOS: $V_{tn} = 0,6 \pm 0.2\text{ V}$ , $U_{sd} > 12\text{ V}$ PMOS: $V_{tp} = 0,6 \pm 0.2\text{ V}$ , $U_{sd} > 12\text{ V}$

• **Base Technology Process** (continued)

Process name	Process Description	Application, electrical parameters
5 V, 2 μm CMOS, 1 Poly, 1 Me  «CMOS20»	Photomasks, pcs. 11 Design rules, μm 2.0 Substrate: type/Res 4.5 2 wells N/P-well depth, μm 6/7 Gate SiO <sub>2</sub> , Å 425/300 Interlevel dielectric: BPSG Channel length: NMOS/PMOS, μm 2.5 pitch Poly, μm 4.5 contacts, μm 2.4*2.4 pitch Me, μm 8.5	Small and medium-scale integration logic IC, V <sub>DD</sub> < 5 V  NMOS: V <sub>tn</sub> = 0.6/0.5 V, U <sub>sd</sub> >12 V PMOS: V <sub>tp</sub> = -0.7 V/-0.5, U <sub>sd</sub> >14 V
1.5 V, 1.6 μm, 1 Poly, 1 Me, low threshold  «CMOS16EN»	Photomasks, pcs. 11 Design rules, μm 1.6 Substrate: /P-type/Res 12 2 wells N/P-well depth, μm 5/6 Gate SiO <sub>2</sub> , Å 300 Interlayer dielectric – BPSG Channel length: NMOS/PMOS, μm 2.0 pitch Poly, μm 3.2 contacts, μm 1.5 pitch Me, μm 3.6	Medium-scale integration digital IC for electronic timepieces and micro calculators, V <sub>DD</sub> 1.5 V÷3 V.  NMOS: V <sub>tn</sub> = 0.5 V, U <sub>sd</sub> >10 V PMOS: V <sub>tp</sub> = -0.5 V, U <sub>sd</sub> >10 V
5 V, 1.2 μm CMOS, 2 Poly, 2 Me, low threshold EEPROM  «CMOS12X»	Photomasks, pcs. 3 marked Design rules, μm 1.2 Substrate: Boron/P-type/Res 12 wells N/P-well depth, μm 5/6 Gate SiO <sub>2</sub> : Low voltage transistors, Å 250 High voltage transistors, Å 350 Tunnel SiO <sub>2</sub> , Å 77 Interlayer dielectric-1: Si <sub>3</sub> N <sub>4</sub> , Å 350 Interlayer dielectric -2: BPSG, Å 7000 Interlevel dielectric: PEoxide+SOG+ PEoxide Channel length: Low voltage NMOS/PMOS, μm 1.4/1.6 High voltage NMOS/PMOS, μm 2.6/2.6 N & P LDD- drains In-built transistors Pitch Poly 1, μm 3.2 Pitch Poly 2, contact free, μm 2.4 Pitch Poly 2, with contact, μm 4,6 contacts-1, μm 1.2 Pitch Me 1, contact free, μm 3.2 Pitch Me 2, with contact, μm 4,4 Contacts 2, μm 1.4 Pitch Me 2, contact free, μm 4.4 Pitch Me 2, with contact, μm 4,8	LSI EEPROM V <sub>DD</sub> 2,4 V÷6 V  LV NMOS: V <sub>tn</sub> =(0,4-0,8)V U <sub>sd</sub> ≥12 V LV PMOS: V <sub>tp</sub> =(0,5-0,9)V U <sub>sd</sub> ≤-12 V HV- NMOS: V <sub>tn</sub> =(0,3-0,6)V U <sub>sd</sub> ≥17 V HV- PMOS: V <sub>tp</sub> =(0,6-1,0)V U <sub>sd</sub> ≤-15 V

# FOUNDRIY BUSINESS

## Base Technology Process

### • Base Technology Process (continued)

Process name	Process Description	Application, electrical parameters
5 V, 0.8 $\mu$ m CMOS, 2 Poly, 1Me, low threshold EEPROM  «CMOS08XE»	Photomasks, pcs. 20 (with marks, reverse pads, lightly doped contacts) Design rules, $\mu$ m 1.2 in «Contacts» & «Metallization» layers, $\mu$ m 0.8 Substrate: Boron/P-type/Res 12 2 wells N/P-well depth, $\mu$ m 5/6 Gate SiO <sub>2</sub> , Å 425 Tunnel SiO <sub>2</sub> , Å 77 Interlayer dielectric -1: Si <sub>3</sub> N <sub>4</sub> , Å 350 Interlayer dielectric -2: BPSG, Å 7000 Built-in transistors Channel length: NMOS/PMOS Low voltage transistors, $\mu$ m 2.4 High voltage transistors, $\mu$ m 3.6 Pitch Poly 1, contact free, $\mu$ m 1.8 Pitch Poly 1, with contact, $\mu$ m 4.6 Pitch Poly 2, $\mu$ m 4.0 Contacts, $\mu$ m 0.8 Me Ti-TiN/Al-Si/TiN Pitch Me, contact free, $\mu$ m 2.4 Pitch Me, with contact, $\mu$ m 3,2	Medium scale integration EEPROM,  $V_{DD}$ 1,8 V $\div$ 6 V  NMOS: $V_{tn}=(0,60\pm 0,20)V$ $U_{sd} \geq 12 V$ PMOS: $V_{tp}=- (0,6\pm 0,2)V$ $U_{sd} \leq -12 V$ HV-NMOS: $V_{tn}=(0,3-0,45)V$ $U_{sd} \geq 16 V$ HV-PMOS: $V_{tp}=- (0,6\pm 0,2)V$ $U_{sd} \leq -16 V$
5 V, 1.5 $\mu$ m CMOS, 1 Poly, 1 Me, Poly- resistors  «CMOS15B» / «CMOS15BY»	Photomasks, pcs. 17 Design rules, $\mu$ m 1.5 Substrate: Boron/P-type/Res 12; Phos/N-type/Res 4.5 2 wells Epi layer no/ Phos/N-type/Thk 8/Res 4.5 2 wells N/P-well depth, $\mu$ m 5/6 P-type Poly resistors Bipolar vertical NPN transistor Gate SiO <sub>2</sub> , Å 250 Interlayer dielectric: BPSG S/PMOS channel length, $\mu$ m 1.7 N&P LDD- drains Pitch Poly, $\mu$ m 2.5 Contacts, $\mu$ m 1.3 Pitch Me, $\mu$ m 3.5	Supply voltage controller IC  NMOS: $V_{tn}= 0.5 / 0,6 V$ , $U_{sd} > 10 V$ PMOS: $V_{tp}= -0.5 / -0.6 V$ , $U_{sd} > 10 V$
3-5 V, 0.8 $\mu$ m CMOS, 1 Poly (2 Poly), 2 Me  «CMOS08D»	Photomasks, pcs. 16 (17) Design rules, $\mu$ m 0.8 Substrate: Phos/N-type/Res 4.5 or Bor/P-type/Res 12 2 wells N/P-well depths, $\mu$ m 4/4 Interlayer dielectric: BPSG Gate SiO <sub>2</sub> , Å 130 / 160 channel length NMOS/PMOS, $\mu$ m 0.9/1.0 N&P LDD- drains Me I Ti-TiN/Al-Si/TiN Pitch Poly, $\mu$ m 1.9 Contacts 1, $\mu$ m 0.9 Pitch 2.2 Me 2 Al-Si/TiN Contacts 2, $\mu$ m 0.9 Pitch Me 2, $\mu$ m 2.4	IC for telecommunication (SLIC), Customized IC, $V_{DD}$ 3 V $\div$ 5 V  NMOS: $V_{tn}=0.6 V$ , $U_{sd} > 10 V$ PMOS: $V_{tp}=-0.8 V$ , $U_{sd} > 10 V$

• **Base Technology Process** (continued)

Process name	Process Description	Application, electrical parameters
10 V, 3,0 μm Bi-CMOS, local n <sup>+</sup> , p <sup>+</sup> - buried layers, Locos+ p-n junction isolation, 2 Poly, 1 Me, specifically resistant,  « <b>BCMOS30Y-10</b> »	Photomasks, pcs 18 Design rules, μm 3.0 Substrate: Boron/P-type/Res 12 N <sup>+</sup> /P <sup>+</sup> buried layers Epi layer Phos/N-type/Thk 20/Res 4.5 N/P-well depth, μm 6/7 Gate SiO <sub>2</sub> , Å 425 Interlayer dielectric: BPSG Channel length: NMOS/PMOS, μm 3.5/3.3 Pitch Poly, μm 5 Contacts, μm 5 Pitch Me, μm 6	Serial interface LSIC, RS-485 standard; V <sub>DD</sub> = 5 V, Vin/ Vout (-7 ± 12)V, specifically resistant  NMOS: V <sub>tn</sub> = (1.0 ±0.2)V , Usd >16 V PMOS: V <sub>tp</sub> = (0.8±0.2)V, Usd >16 V
5V, high voltage 0.8 μm CMOS, 2 Poly, 1 Me, EEPROM  « <b>CMOS08HXE</b> »	Photomasks, pcs. 19 (with marks, reverse pads, underdoped contacts) Design rules, μm 0.8 (in «Contacts» & «Metallization» layers) Substrate: Boron/P-type/Res 12 1 well N-well depth, μm 4 Gate SiO <sub>2</sub> : High voltage transistors, Å 350 Tunnel SiO <sub>2</sub> , Å 77 Interlayer dielectric -1: Si <sub>3</sub> N <sub>4</sub> , Å 350 Interlayer dielectric -2: BPSG, μm 0,55±0,5 Interlevel dielectric:-3: PEoxide+SOG+ PEoxide, μm 0,7±0,1 Channel length: High-voltage NMOS/PMOS, μm 2,6/2,6 N & P LDD- drains In-built transistors Pitch Poly1, contact free, μm 1.8 Pitch Poly1, with contact, μm 4,6 Pitch Poly 2, contact free, μm 1,8 Contacts, μm 0.8 Me Ti-TiN/Al-Si/TiN Pitch Me, contact free, μm 2.4 Pitch Me, with contact, μm 3,2	LSI EEPROM, V <sub>DD</sub> 1.8 V÷6 V  HV- NMOS: V <sub>tn</sub> =(0,3-0,7)V Usd≥17 V HV- PMOS: V <sub>tp</sub> =(0,4-0,9)V Usd ≤-17 V

# FOUNDRIY BUSINESS

## Base Technology Process

### • Base Technology Process (continued)

Process name	Process Description	Application, electrical parameters
<b>Bipolar CDMOS</b>		
200 V, with p-n junction isolation, 1 Poly, 1 Me, NDMOS/PDMOS high-voltage transistors  «BCDMOS30-200»	Photomasks, pcs. 19 Mean design rule, $\mu\text{m}$ 4.0 EPI WAFER: Epi layer: Phos/ N-type/ Thk 27/ Res 8; Buried layers: Sb/N-type/Thk 30/Res 5.5; Boron/P-type/Thk 300/Res2.0 Substrate: Boron/ P-type/ Thk 460/ Res 60/ Orientation (100)  Isolation: p-n junction P-well depth, $\mu\text{m}$ 6.5 NDMOS base depth, $\mu\text{m}$ 3.0 Gate SiO <sub>2</sub> , Å 900 NPN p-base depth, $\mu\text{m}$ 2.5 N+emitter depth, $\mu\text{m}$ 0.8 Interlayer dielectric – low temp. PCG 0,55 $\mu\text{m}$ +SIPOS 0.1 $\mu\text{m}$ + low temp. PCG 1,1 $\mu\text{m}$ Channel length (gate): NDMOS/PMOS, $\mu\text{m}$ 6 Pitch Poly, $\mu\text{m}$ 8 Contacts, $\mu\text{m}$ 4 Pitch Me, $\mu\text{m}$ 12	Small -scale integration analogue IC, $V_{DD} < 210 \text{ V}$  NPN Vertical: $\beta_n = 70$ Uce=50 V NDMOS: Vtn= 2.0 V, Usd >200 V PDMOS: Vtp= -1.0 V, Usd >200 V NMOS: Vtn= 1.5 V , Usd >20 V  Resistors in layer: NPN base, P-drain, Poly.  Capacitors: Poly-Si (SiO <sub>2</sub> 900 Å) Poly-Al (SiO <sub>2</sub> 1600 Å)
90 V, p-n junction isolation, 1 Poly, 1 Me, NMOS/PMOS low-voltage transistors, NDMOS/PDMOS high-voltage lateral transistors, power vertical NDMOS transistor, bipolar vertical NPN & lateral PNP transistors  «BCDMOS30-90»	Photomasks, pcs. 19 Mean design rule, $\mu\text{m}$ 4.0 EPI WAFER: Epi layer: Phos/ N-type/ Thk 12/ Res 1.5; Buried layers: Sb/N-type/Thk 20/Res 6; Boron/P-type/Thk 250/Res2.0 Substrate: Boron/ P-type/ Thk 460/ Res 12/ Orientation (100)  Isolation: p-n junction P-well depth, $\mu\text{m}$ 6.5 NDMOS base depth, $\mu\text{m}$ 2.5 Gate SiO <sub>2</sub> , Å 750 NPN p-base depth, $\mu\text{m}$ 2.5 N+emitter depth, $\mu\text{m}$ 0.5 Interlayer dielectric - BPSG, $\mu\text{m}$ 0,8 Channel length (gate): NMOS/PMOS, $\mu\text{m}$ 7 Contacts, $\mu\text{m}$ 2 Pitch Me, $\mu\text{m}$ 8	Small and medium-scale integration analogue IC, $V_{DD} < 90 \text{ V}$  NPN Vertical: $\beta_n = 50$ Uce=20 V PNP Lateral: $\beta_p = 25$ Uce=20 V  LNDMOS Vtn= 2.0 V, Usd >90 V LPDMOS: Vtp= -1.4 V, Usd >90 V NMOS: Vtn= 1.2 V, Usd >18 V PMOS: Vtp= 1.5 V, Usd >18 V VNDMOS: Vtn= 2.0 V, Usd >70 V  Resistors in layer: NDMOS base, P-drain, Poly.  Capacitors: Poly-Si (SiO <sub>2</sub> 750 Å) Poly-Al (SiO <sub>2</sub> 8000 Å)

• **Mask Making**

ITEM	SPECIFICATIONS
<p><b>MASKS FOR STEPPER (RETICLES) SCALE 10:1 (SODA LIME PLATE)</b></p>	<ol style="list-style-type: none"> <li>Type of masking layer: C - chromium, ARC - antireflective chromium</li> <li>Min feature – 4 μm Deviation ± 0.15 μm</li> <li>Max defect size – 2.0 μm; 1.5 μm; 1.0 μm</li> <li>Accuracy alignment in mask set – to 0.8 μm</li> <li>Sizes of plate: 127 x 127 x 2.4 mm (5"sq. x 0.090") 153 x 153 x 2.4 mm (6"sq. x 0.090")</li> </ol>
<p><b>MASKS FOR STEPPER (RETICLES) SCALE 5:1 (SODA LIME PLATE)</b></p>	<ol style="list-style-type: none"> <li>Type of masking layer: C – chromium, ARC – antireflective chromium</li> <li>Min feature – 2 μm Deviation ± 0.10 μm</li> <li>Max defect size – 2.0 μm; 1.5 μm; 1.0 μm</li> <li>Accuracy alignment in mask set – to 0.6 μm</li> <li>Sizes of plate: 127 x 127 x 2.4 mm (5"sq. x 0.090") 153 x 153 x 2.4 mm (6"sq. x 0.090")</li> </ol>
<p><b>MASKS FOR STEPPER (RETICLES) SCALE 5:1 (QUARTZ PLATE)</b></p>	<ol style="list-style-type: none"> <li>Type of masking layer: C – chromium, ARC–antireflective chromium</li> <li>Min feature – 2 μm Deviation ± 0.10 μm</li> <li>Max defect size – 2.0 μm; 1.5 μm; 1.0 μm</li> <li>Accuracy alignment in mask set – to 0.6 μm</li> <li>Sizes of plate: 152 x 152 x 6.35 mm (6"sq. x 0.250")</li> </ol>
<p><b>MASKS 1:1 (FOR PROJECTION AND CONTACT LITHOGRAPHY)</b></p>	<ol style="list-style-type: none"> <li>Type of masking layer: C – chromium, ARC– antireflective chromium, Fe<sub>2</sub>O<sub>3</sub> –ferroxide</li> <li>Min feature – 1.2 μm Deviation ± 0.10 μm</li> <li>Accuracy alignment in mask set ± 0.3 μm</li> <li>Sizes of plate: 102 x 102 (4"sq. x 0.090") 127 x 127 (5"sq. x 0.090") 153 x 153 (6"sq. x 0.090")</li> </ol>
<p><b>MASK BLANKS</b></p>	<ol style="list-style-type: none"> <li>Sizes of plate: 102 x 102 x 2.4 mm (4"sq. x 0.090") 127 x 127 x 2.4 mm (5"sq. x 0.090") 153 x 153 x 2.4 mm (6"sq. x 0.090")</li> <li>Type of glass: soda lime</li> <li>Type of masking layer: C – chromium, ARC– antireflective chromium, Fe<sub>2</sub>O<sub>3</sub>- ferroxide</li> <li>Type of resist layer: positive photoresist, positive electronesist</li> </ol>

Tel.: (375 17) 278 1916  
212 1060

Fax: (375 17) 2781 622  
2787 980

E-mail: [dzfotek@integral.by](mailto:dzfotek@integral.by)  
[dzfotek2@integral.by](mailto:dzfotek2@integral.by)

# SERVICES

## Development And Production

<i>Silicon Foundry</i>	<ol style="list-style-type: none"> <li>1. Integrated circuits</li> <li>2. Discrete devices: <ul style="list-style-type: none"> <li>- bipolar and MOS transistors</li> <li>- diodes</li> </ul> </li> </ol>
<i>Foundry Services</i>	<ol style="list-style-type: none"> <li>1. ICs manufacture (wafer, chips, chips on the wafer) on the base of 0.5 – 2.0 <math>\mu\text{m}</math> design rule and Customer's Technical Specification.</li> <li>2. Packaging on the base of Customer's dies: SOP, DIP, QFP, SIP, SIL, TO packages.</li> <li>3. Development of ICs and electronic instruments/ devices.</li> <li>4. Mask making.</li> <li>5. Development of electronic devices and manufacture of samples as per Customer's requirements.</li> </ol>
<i>Design of Electronic Components</i>	<ol style="list-style-type: none"> <li>1. Liquid-crystal displays and panels: <ul style="list-style-type: none"> <li>- twist nematic</li> <li>- super twist nematic</li> </ul> </li> </ol>
<i>Design and Manufacture of Various Products for Semiconductor and Electronic Industries</i>	<ol style="list-style-type: none"> <li>1. Lead frames for integrated circuits and discrete devices</li> <li>2. Photomasks and mask blanks</li> <li>3. Silicon substrates and epi structures</li> <li>4. Printed boards</li> <li>5. Attachment of packageless integrated circuits on printed board and wiring</li> <li>6. Mounting of parts on printed board</li> <li>7. Molding of pellets for encapsulation of transistors and ICs</li> </ol>
<i>Development of Software</i>	<ol style="list-style-type: none"> <li>1. Software for integrated circuit CAD systems those use PC/AT and workstations of Hewlett-Packard</li> <li>2. Adaptation of CAD software of Mentor Graphics and Cadence to user's conditions</li> <li>3. Application software under the management of MS DOS and WINDOWS shell</li> <li>4. Software for automatic control systems with the use of various database management systems</li> <li>5. Tested software for microprocessor systems</li> <li>6. Manager programs for microprocessor systems</li> <li>7. Examination of program products</li> </ol>
<i>Design and Manufacture of Machine-Tool Attachments</i>	<ol style="list-style-type: none"> <li>1. Molds</li> <li>2. Blanking dies</li> <li>3. Quartz work tools</li> <li>4. Fluoroplastic tools</li> <li>5. Hard alloy workpieces and stamping parts</li> <li>6. Die attachment and bonding tools</li> <li>7. Jigs, fixtures, mechanisms, etc.</li> <li>8. Stamping and forming of details. The force is up to 100 tons</li> <li>9. High-temperature processing of quartz glass</li> </ol>
<i>Testing</i>	<ol style="list-style-type: none"> <li>1. Testing of electronic parts and apparatuses with the purpose of certifying</li> </ol>
<i>Analysis</i>	<ol style="list-style-type: none"> <li>1. Technical examination of electronic products failure causes when a customer and supplier are in discord</li> <li>2. Non-destructive analysis of solid state materials element composition of high sensitivity and locality with electron and ion spectroscopy methods and X-photoemission spectroscopy analysis</li> <li>3. Object structure and surface microanalysis with the use of <math>1000000^{\times}</math> scanning electron and transmission electron microscopes</li> <li>4. Measurements of electrophysical and optical parameters of solid state samples including R-, C-, L-parameters, micro- and macroobjects surface temperature extension, spectrophotometrical measurements, buried defect analysis with the use of acoustic microscopy</li> <li>5. Test and analysis of various chemical materials for conformity with specifications</li> </ol>

# **TRANSISTOR**

# DISCRETE SEMICONDUCTORS

## Transistors

### • Bipolar Transistors

Part	Pin to Pin Compatibility	Polarity	P <sub>c</sub> max, W	V <sub>CB</sub> max, V	V <sub>CE</sub> max, V	V <sub>EB</sub> max, V	I <sub>c</sub> max, mA	h <sub>FE</sub>	V <sub>CE</sub> sat, V	I <sub>CBO</sub> , μA	F <sub>T</sub> , MHz	Nf, dB	Package
KT220A9 KT220B9 KT220B9 KT220Г9	KSC1623	NPN	0.2	60	50	5	100	90...180 135...270 200...400 300...600	0.3	0.1	250		SOT-23
KT3102AM KT3102БМ KT3102BM KT3102ГМ KT3102ДМ KT3102ЕМ KT3102ЖМ KT3102ИМ KT3102КМ	BC547A BC547B BC548B BC548C BC549B BC549C	NPN	0.25	50 50 30 20 30 20 50 50 30	50 50 30 20 30 20 50 50 30	5	200	100...250 200...500 200...500 400...800 200...500 400...1000 100...250 200...500 200...500	0.25	0.05 0.05 0.015 0.015 0.015 0.015 0.05 0.05 0.015	200 200 200 200 300 300 200 200 200	10 10 10 10 4 4 - - -	TO-92
KT3107A KT3107Б KT3107B KT3107Г KT3107Д KT3107E KT3107Ж KT3107И KT3107K KT3107Л	BC307A BC308A BC308B BC309B BC307B BC308C BC309C	PNP	0.3	50 50 30 30 30 25 25 50 30 25	45 45 25 25 25 20 20 45 25 20	5	100	70...140 120...220 70...140 120...220 180...460 120...220 180...460 180...460 380...800 380...800	0.2	0.1	250	10 10 10 10 4 4 10 10 4	TO-92
KT3117A KT3117Б KT3117A1	2N2221 2N2222 PN2222	NPN	0.3 0.3 0.5	60 75 60	60 75 60	4	400	40...200 100...300 40...200	0.6	10	200		TO-18 TO-92 TO-92
KT3126A	BF506	PNP	0.15	30	30	3	30	25...100	1.2	0.5	500	5	TO-92
KT3127A	2N4411	PNP	0.1	20	20	3	25	25...150		1.0	600	5	TO-72
KT3128A		PNP	0.1	40	40	3	20	15...150		1.0	700	5	TO-92
KT3129A9 KT3129Б9 KT3129B9 KT3129Г9 KT3129Д9	BC857A BC858A BC858B	PNP	0.1	50 50 30 30 20	40 40 20 20 20	5	100	30...120 80...250 80...250 200...500 200...500	0.2	1.0	200		SOT-23
KT3130A9 KT3130Б9 KT3130B9 KT3130Г9 KT3130Д9 KT3130E9 KT3130Ж9	BCW71 BCW72 BCW32	NPN	0.1	50 50 30 20 30 20 30	40 40 20 15 20 15 25	5	100	100...250 200...500 200...500 400...1000 200...500 400...1000 100...500	0.3	0.1	150 150 150 300 150 300 150	- 10 10 10 4 4 -	SOT-23
KT3142A	2N2369	NPN	0.36	40	40	4.5	200	40...120	0.25	0.4	500		TO-18
KT3157A	BF423	PNP	0.2	250	250	5	30	>50	1.0	0.1	60		TO-92
KT3189A9 KT3189Б9 KT3189B9	BC847A BC847B BC847C	NPN	0.225	50	45	6	100	110...220 200...450 420...800	0.6	0.015	300	10	SOT-23
KT368A9 KT368B9	BF599	NPN	0.1	15	15	4	30	50...300		0.5	900	3.3	SOT-23

• **Bipolar Transistors** (continued)

Part	Pin to Pin Compatibility	Polarity	P <sub>C</sub> max, W	V <sub>CB</sub> max, V	V <sub>CE</sub> max, V	V <sub>EB</sub> max, V	I <sub>C</sub> max, mA	h <sub>FE</sub>	V <sub>CE</sub> sat, V	I <sub>CB0</sub> , μA	F <sub>T</sub> , MHz	Nf, dB	Package
KT502A KT502Б KT502B KT502Г KT502Д KT502E	KSA539 BC212	PNP	0.35	40 40 60 60 80 90	25 25 40 40 60 80	5	150	40...120 80...240 40...120 80...240 40...120 40...120	0.6	1	5		TO-92
KT503A KT503Б KT503B KT503Г KT503Д KT503E	KSC815 BC183	NPN	0.35	40 40 60 60 80 100	25 25 40 40 60 80	5	150	40...120 80...240 40...120 80...240 40...120 40...120	0.6	1	5		TO-92
KT520A KT520Б	MPSA42 MPSA43	NPN	0.625	300 200	300 200	6	500	>40	0.5 0.4	100	50		TO-92
KT521A KT521Б	MPSA92 MPSA93	PNP	0.625	300 200	300 200	5	500	>40	0.5 0.4	100	50		TO-92
KT538A	MJE13001	NPN	0.7	600	400	9	500	5...90	0.5	I <sub>кэК</sub> 100	4		TO-92
KT6109A KT6109Б KT6109B KT6109Г KT6109Д	SS9012D SS9012E SS9012F SS9012G SS9012H	PNP	0.625	40	20	5	500	64...91 78...112 96...135 112...166 144...202	0.6	0.1			TO-92
KT6110A KT6110Б KT6110B KT6110Г KT6110Д	SS9013D SS9013E SS9013F SS9013G SS9013H	NPN	0.625	40	20	5	500	64...91 78...112 96...135 112...166 144...202	0.6	0.1			TO-92
KT6111A KT6111Б KT6111B KT6111Г	SS9014A SS9014B SS9014C SS9014D	NPN	0.45	50	45	5	100	60...150 100...300 200...600 400...1000	0.3	0.05	150	10	TO-92
KT6112A KT6112Б KT6112B	SS9015A SS9015B SS9015C	PNP	0.45	50	45	5	100	60...150 100...300 200...600	0.7	0.05	100	10	TO-92
KT6113A KT6113Б KT6113B KT6113Г KT6113Д KT6113E	SS9018D SS9018E SS9018F SS9018G SS9018H SS9018I	NPN	0.4	30	15	5	50	28...45 39...60 54...80 72...108 97...146 132...198	0.5	0.05	700		TO-92
KT6114A KT6114Б KT6114B KT6114Г KT6114Д KT6114E	SS8050B SS8050C SS8050D	NPN	1.0 1.0 1.0 0.7 0.7 0.7	40	25	6	1500 1500 1500 1100 1100 1100	85...160 120...200 160...300 85...160 120...200 160...300	0.5	0.1	100		TO-92
KT6115A KT6115Б KT6115B KT6115Г KT6115Д KT6115E	SS8550B SS8550C SS8550D	PNP	1.0 1.0 1.0 0.7 0.7 0.7	40	25	6	1500 1500 1500 1100 1100 1100	85...160 120...200 160...300 85...160 120...200 160...300	0.5	0.1	100		TO-92
KT6116A KT6116Б	2N5401 2N5400	PNP	0.625	160 130	150 120	5	600	60...240 40...180	0.5	0.05 0.1	100	8	TO-92
KT6117A KT6117Б	2N5551 2N5550	NPN	0.625	180 160	160 140	6	600	80...250 60...250	0.2 0.25	0.05 0.1	100	8	TO-92

# DISCRETE SEMICONDUCTORS

## Transistors

### • Bipolar Transistors (continued)

Part	Pin to Pin Compatibility	Polarity	P <sub>c</sub> max, W	V <sub>CB</sub> max, V	V <sub>CE</sub> max, V	V <sub>EB</sub> max, V	I <sub>c</sub> max, mA	h <sub>FE</sub>	V <sub>CE</sub> sat, V	I <sub>CB0</sub> , μA	F <sub>T</sub> , MHz	Nf, dB	Package
KT6128A KT6128Б KT6128B KT6128Г KT6128Д KT6128E	SS9016D SS9016E SS9016F SS9016G SS9016H SS9016I	NPN	0.4	30	20	4	25	28...45 39...60 54...80 72...108 97...146 132...198	0.3	0.1	400	5	TO-92
KT6136A	2N3906	PNP	0.625	40	40	5	200	100...300	0.4	0.05	250		TO-92
KT6137A	2N3904	NPN	0.625	60	40	6	200	100...300	0.3	0.05	300		TO-92
	BC639	NPN	0.625	100	80	5	1500	≥25	0.5	0.1	100		TO-92
	BC640	PNP	0.625	100	80	5	1500	≥25	0.5	0.1	100		TO-92
KT635Б	2N3725	NPN	0.5	60	60	5	1000	20...150	0.52	30	300		TO-126
KT646A KT646Б KT646В	2SC495 2CS496	NPN	1.0	60 40 40	60 40 40	4	1000	40...200 >150 150...340	0.85 0.25 0.25	10 10 0.05	250		TO-126
KT660A KT660Б	BC337 BC338	NPN	0.5	50 30	45 30	5	800	110...220 200...450	0.5	1.0	200		TO-92
KT732A KT733A	MJE4343 MJE4353	NPN PNP	125	160	160	7	16000	8...15	2.0	750	1.0		TO-218
KT738A KT739A	TIP3055 TIP2955	NPN PNP	90	70	60	5	15000	20...100	1.1	1000			TO-218
KT805AM KT805БM KT805BM KT805ИM		NPN	30	300	U <sub>cer</sub> 160 135 135 60	5	5000	>15 >15 >15 >25	- - 2.5 3.0	1.0			TO-92
KT814A KT814Б KT814В KT814Г	BD136 BD138 BD140	PNP	10		40 50 70 100	5	1500	40...275 40...275 40...275 30...275	0.6	50	40		TO-126
KT815A KT815Б KT815В KT815Г	BD135 BD137 BD139	NPN	10		40 50 70 100	5	1500	40...275 40...275 40...275 30...275	0.6	50	40		TO-126
KT816A KT816Б KT816В KT816Г	BD234 BD236 BD238	PNP	25		40 45 60 100	5	3000	25...275	0.6	100	3.0		TO-126
KT817A KT817Б KT817В KT817Г	BD233 BD235 BD237	NPN	25		40 45 60 100	5	3000	25...275	0.6	100	3.0		TO-126
KT8126A1 KT8126Б1	MJE13007 MJE13006	NPN	80	700 600	400 300	9	8000	8...40	1.0	1000	4.0		TO-220
KT8164A KT8164Б	MJE13005 MJE13004	NPN	75	700 600	400 300	9	4000	8...40	1.0	1000			TO-220
KT8170A1 KT8170Б1	MJE13003 MJE13002	NPN	40	700 600	400 300	9 9	1500	8...40	1.0	1000	4.0		TO-126
KT8176A KT8176Б KT8176В	TIP31A TIP31B TIP31C	NPN	40	60 80 100	60 80 100	5	3000	>25	1.2	I <sub>CS</sub> =300	3.0		TO-220

• **Bipolar Transistors** (continued)

Part	Pin to Pin Compatibility	Polarity	P <sub>C</sub> max, W	V <sub>CB</sub> max, V	V <sub>CE</sub> max, V	V <sub>EB</sub> max, V	I <sub>C</sub> max, mA	h <sub>FE</sub>	V <sub>CE</sub> sat, V	I <sub>CB0</sub> , μA	F <sub>T</sub> , MHz	Nf, dB	Package
KT8177A KT8177B KT8177B	TIP32A TIP32B TIP32C	PNP	40	60 80 100	60 80 100	5	3000	>25	1.2	I <sub>CES</sub> =300	3.0		TO-220
KT8212A KT8212B KT8212B	TIP41C TIP41B TIP41A	NPN	65	60 80 100	60 80 100	5	6000	15...75	1.5	I <sub>CES</sub> =400	3.0		TO-220
KT8213A KT8213B KT8213B	TIP42C TIP42B TIP42A	PNP	65	60 80 100	60 80 100	5	6000	15...75	1.5	I <sub>CES</sub> =400	3.0		TO-220
KT8213A	MJE2955	PNP	75	70	60	5	10000	20...100	1.1	1000			TO-220
KT8212A	MJE3055	NPN	75	70	60	5	10000	20...100	1.1	1000			TO-220
KT8224A KT8224B	BU2508A BU2508D	NPN	100	1500	700	7.5	8000	4...7 4...9	1.0 1.5	1000			TO-218
KT8225A	BU941ZP	NPN	155	350	350	5	15000	>300	2.7	100			TO-218
KT8228A KT8228B	BU2525A BU2525D	NPN	125	1500	800	7.5 6.0	12000	5.0...9.5	5.0	I <sub>CEO</sub> =1.0			TO-218
KT8229A	TIP35F	NPN	125	180	180	5	25000	15...75	1.8	I <sub>CEO</sub> =1.0	3.0		TO-218
KT8230A	TIP36F	PNP	125	180	180	5	25000	15...75	1.8	1.0	3.0		TO-218
KT8247A	BUL45D2	NPN	75	700	400	12	5000	>22	0.5	100			TO-220
KT8248A1	BU2506D	NPN	90	U <sub>cek</sub> 1500	700	7.5	5000	3.8...9.0	3.0				TO-218
KT8261A	BUD44D2	NPN	25	700	400	9	2000	>10	0.65	0.1			TO-126
	BUL44D2	NPN	40	700	400	9	5000	>10	0.65	0.1			TO-220
KT8270A	MJE13001	NPN	0.7	600	400	9	0.5	5...90	0.5	1000	4		TO-126
KT8271A KT8271B KT8271B	BD136 BD138 BD140	PNP	10.0	45 60 80	45 60 80	5	1500	>25	0.5	0.1			TO-126
KT8272A KT8272B KT8272B	BD135 BD137 BD139	NPN	10.0	45 60 80	45 60 80	5	1500	>25	0.5	0.1			TO-126
KT8290A	BUH100	NPN	100	700	400	9	10000	>10	1.0				TO-220
KT8296A KT8296B KT8296B KT8296Γ	KSD882R KSD882O KSD882Y KSD882G	NPN	10	40	30	5	3000	60...120 100...200 160...320 200...400	0.5	100			TO-126
KT8297A KT8297B KT8297B KT8297Γ	KSB772R KSB772O KSB772Y KSB772G	PNP	10	40	30	5	3000	60...120 100...200 160...320 200...400	0.5	100			TO-126
KT872A KT872B KT872B	BU508A BU508	NPN	100	1500 1500 1200	700 700 600	6	8000	>6	0.5 5.0 1.0	1.0 1.0 0.6	4.0		TO-218
KT928A	2N2218	NPN	0.5	60	60	5	0.8	20...100	1.0	5.0	250		TO-126
KT928B	2N2219	NPN	0.5	60	60	5	0.8	50...200	1.0	5.0	250		TO-126
KT928B	2N2219A	NPN	0.5	75	75	5	0.8	100...300	1.0	1.0	250		TO-126
KT940A KT940B KT940B	BF459 BF458 BF457	NPN	10	300 250 160	300 250 160	5	100	>25	1.0	0.05			TO-126
KT969A	BF469	NPN	6	300	250	5	100	50...250	1.0	0.05	60		TO-126

# DISCRETE SEMICONDUCTORS

## Transistors

### • Power Bipolar Darlington Transistors

Part	Pin to Pin Compatibility	Polarity	P <sub>C</sub> max, W	V <sub>CB</sub> max, V	V <sub>CE</sub> max, V	V <sub>EB</sub> max, V	I <sub>C</sub> max, mA	h <sub>FE</sub>	V <sub>CE</sub> sat, V	I <sub>CB0</sub> , μA	F <sub>T</sub> , MHz	Package
KT8115A KT8115B KT8115B	TIP127 TIP126 TIP125	PNP	65	100 80 60	100 80 60	5	5000	>1000	2.0	200	4	TO-220
KT8116A KT8116B KT8116B	TIP122 TIP121 TIP120	NPN	65	100 80 60	100 80 60	5	5000	>1000	2.0	200	4	TO-220
KT8214A KT8214B KT8214B	TIP110 TIP111 TIP112	NPN	50	60 80 100	60 80 100	5	2000	>500	2.5	1000		TO-220
KT8215A KT8215B KT8215B	TIP115 TIP116 TIP117	PNP	50	60 80 100	60 80 100	5	2000	>500	2.5	1000		TO-220
KT8156A KT8156B	BU807	NPN	60	330	150 200	6	8000	>100	1.5	1000		TO-220
KT8158A KT8158B KT8158B	BDV65A BDV65B BDV65C	NPN	125	60 80 100	60 80 100	5	12000	>1000	2.0	400		TO-218
KT8159A KT8159B KT8159B	BDV64A BDV64B BDV64C	PNP	125	60 80 100	60 80 100	5	12000	>1000	2.0	400		TO-218
KT8225A	BU941ZP	NPN	155	350	350	5	15000	>300	2.7	100		TO-218
KT8251A	BDV65F	NPN	125	180	180	5	10000	>100	2.0	0.4		TO-218
KT972A KT972B KT972B KT972Г	BD875	NPN	8.0	60 45 60 60	60 45 60 60	5	2000	>750 >750 750... 5000 750... 5000	1.5 1.5 1.5 0.95		200	TO-126
KT973A KT973B KT973B	BD876	PNP	8.0	60 45 60	60 45 60	5	2000	>750 >750 750... 5000	1.5 1.5 1.5		200	TO-126

### • Unijunction Transistors

Part	Pin to Pin Compatibility	P max, W	V <sub>b</sub> , b2 max, V	I <sub>e</sub> pulse, A	I <sub>e</sub> rev, μA	V <sub>eb</sub> sat, V	η	Package
KT132A KT132B	2N2646 2N2647	0.3	35	2.0	12.0 0.2	0.7...3.5	0.56...0.75 0.68...0.82	Case 22A-01
KT133A KT133B	2N4870 2N4871	0.3	35	1.5	1.0	0.7...2.5	0.56...0.75 0.70...0.85	TO-92

• **Low Power N-Channel MOSFETs**

Part	Pin to Pin Compatibility	P max, W	Vgs max, V	Vds max, V	Vgs(off), V	Rds(on) Ohm	Id max, mA	g fs, A/V	Package
КП214А9	2N7002LT1	0.2	±40	60	1.0÷2.5	7.5	115	0.08	SOT-23
КП501А КП501Б КП501В	ZVN2120	0.5	±20	240 200 200	1.0÷3.0 1.0÷3.0 -	10 10 15	180	>0.1	TO-92
КП502А	BSS124	0.7	±10	400	1.5÷2.5	28	120	0.1	TO-92
КП504А,Б КП504В КП504Г КП504Д КП504Е	BSS88	1.0 0.7 0.7 0.7 0.7	±10	240 200 250 240 240	0.6÷1.2	8 8 10 8 8	250 200 180 200 200	0.14	TO-92
КП505А,Б КП505В КП505Г	BSS295	1.0 1.0 0.7	±20 ±20 ±10	50 60 8	0.8÷2.0 0.8÷2.0 0.4÷0.8	0.3 0.3 1.2	1400 1400 500	0.5 0.5 -	TO-92
КП509А9 КП509Б9 КП509В9	BSS131	0.36 0.50 0.36	±14	240 240 200	0.8÷2.0 0.6÷1.2 0.8÷2.0	16 8 16	100 250 100	0.16 0.14 0.06	TO-92
КП511А КП511Б	TN0535 TN0540	0.75	±20	350 400	0.8÷2.0	22	140	0.125	TO-92
КП523А	BSS297А	0.7	±14	200	0.8÷2.0	2.0	480	0.5	TO-92

• **Low Power P-Channel MOSFETs**

Part	Pin to Pin Compatibility	P max, W	Vgs max, V	Vds max, V	Vgs(off), V	Rds(on), Ohm	Id max, mA	g fs, A/V	Package
КП507А	BSS315	1.0	±20	-50	-0.8÷(-2.0)	0.8	-1100	0.25	TO-92
КП508А	BSS92	1.0	±20	-240	-0.8÷(-2.0)	20	-150	0.06	TO-92

• **Logic Level N-Channel MOSFETs**

Part	Pin to Pin Compatibility	Vds max, V	Rds (on) Ohm	Id max, A	Vgs max, V	P max, W	Vgs (th), V	Package
КП723Г	IRLZ44	60	0.028	50	±10	150	1.0...2.0	TO-220
КП727В	IRLZ34	60	0.05	30	±10	88	1.0...2.0	TO-220
КП744Г	IRL520	100	0.27	9.2	±10	60	1.0...2.0	TO-220
КП745Г	IRL530	100	0.22	15	±10	88	1.0...2.0	TO-220
КП746Г	IRL540	100	0.077	28	±10	150	1.0...2.0	TO-220
КП737Г	IRL630	200	0.4	18	±10	50	1.0...2.0	TO-220
КП750Г	IRL640	200	0.18	18	±10	50	1.0...2.0	TO-220
КП775А КП775Б КП775В	2SK2498А 2SK2498Б 2SK2498В	60 55 60	0.009 0.009 0.011	50	±20	150	1.0...2.0 1.0...2.0 1.0...2.0	TO-220

# DISCRETE SEMICONDUCTORS

## Transistors

### • Power N-Channel MOSFETs

Part	Pin to Pin Compatibility	Vds max, V	Rds (on), $\Omega$	Id max, A	Vgs max, V	P max, W	Vgs (th), V	Package
KП723А	IRFZ44	60	0.028	50	±20	150	2.0...4.0	TO-220
KП723Б	IRFZ45	60	0.035	50				
KП723В	IRFZ40	50	0.028	50				
KП726А	BUZ90А	600	2.0	4.0	±20	75	2.0...4.0	TO-220
KП726Б	BUZ90		1.6	4.5				
KП727А	BUZ71	50	0.1	14	±20	75	2.0...4.0	TO-220
KП727Б	IRFZ34	60	0.05	30				
KП728Г1,Г2	BUZ80А	700	5.0	3.0	±20	75	2.0...4.0	TO-220
KП728С1,С2		650	4.0					
KП728Е1,Е2		600	3.0					
KП737А	IRF630	200	0.4	9.0	±20	74	2.0...4.0	TO-220
KП737Б	IRF634	250	0.45	8.1				
KП737В	IRF635	200	0.68	6.5				
KП739А	IRFZ14	60	0.2	10	±20	43	2.0...4.0	TO-220
KП739Б	IRFZ10	50	0.2	10				
KП739В	IRFZ15	60	0.3	8.3				
KП740А	IRFZ24	60	0.1	17	±20	60	2.0...4.0	TO-220
KП740Б	IRFZ20	50	0.1	17				
KП740В	IRFZ25	60	0.12	14				
KП741А	IRFZ48	60	0.018	50	±20	190	2.0...4.0	TO-220
KП741Б	IRFZ46	50	0.024			150		
KП742А	STH75N06	60	0.014	75	±20	200	2.0...4.0	TO-218
KП742Б	STH80N05	50	0.012	80				
KП743А	IRF510	100	0.54	5.6	±20	43	2.0...4.0	TO-220
KП743Б	IRF511	80	0.54	5.6				TO-126
KП743В	IRF512	100	0.74	4.9				
KП743А1	IRF510	100	0.54	5.5	±20	40	2.0...4.0	TO-126
KП744А	IRF520	100	0.27	9.2	±20	60	2.0...4.0	TO-220
KП744Б	IRF521	80	0.27	9.2				
KП744В	IRF522	100	0.36	8.0				
KП745А	IRF530	100	0.16	14.0	±20	88	2.0...4.0	TO-220
KП745Б	IRF531	80	0.16	14.0				
KП745В	IRF532	100	0.23	12.0				
KП746А	IRF540	100	0.077	28.0	±20	150	2.0...4.0	TO-220
KП746Б	IRF541	80	0.077	28.0				
KП746В	IRF542	100	0.1	25.0				
KП747А	IRFP150	100	0.055	41.0	±20	230	2.0...4.0	TO-218
KП748А	IRF610	200	1.5	3.3	±20	36	2.0...4.0	TO-220
KП748Б	IRF611	150	1.5	3.3				
KП748В	IRF612	200	2.4	2.6				
KП749А	IRF620	200	0.8	5.2	±20	50	2.0...4.0	TO-220
KП749Б	IRF621	150	0.8	5.2				
KП749В	IRF622	200	1.2	4.0				
KП750А	IRF640	200	0.18	18.0	±20	125	2.0...4.0	TO-220
KП750Б	IRF641	150	0.18	18.0				
KП750В	IRF642	200	0.22	16.0				
KП731А	IRF710	400	3.6	2.0	±20	36	2.0...4.0	TO-220
KП731Б	IRF711	350	3.6	2.0				
KП731В	IRF712	400	5.0	1.7				

• **Power N-Channel MOSFETs** (continued)

Part	Pin to Pin Compatibility	Vds max, V	Rds (on), Ohm	Id max, A	Vgs max, V	P max, W	Vgs (th), V	Package
КП751А	IRF720	400	1.8	3.3	±20	50	2.0...4.0	TO-220
КП751Б	IRF721	350	1.8	3.3				
КП751В	IRF722	400	2.5	2.8				
КП771А	STP40N10	100	0.04	40	±20	150	2.0...4.0	TO-220
КП778А	IRFP250	200	0.085	30.0	±20	190	2.0...4.0	TO-220
КП780А	IRF820	500	3.0	2.5	±20	50	2.0...4.0	TO-220
КП780Б	IRF821	450	3.0	2.5				
КП780В	IRF822	500	4.0	2.2				

• **Power P-Channel MOSFETs**

Part	Pin to Pin Compatibility	Vds max, V	Rds (on), Ohm	Id max, A	Vgs max, V	P max, W	Vgs (th), V	Package
КП784А	IRF9Z34	-60	0.14	-18.0	±20	88	-2.0...-4.0	TO-220
КП785А	IRF9540	-100	0.20	-19.0	±20	150	-2.0...-4.0	TO-220
КП796А <i>Under Development</i>	IRF9634	-250	1.0	-4.1	±20	74	-2.0...-4.0	TO-220
КП7128Б	IRF5210	-100	0.08	-35	±20	200	-2.0÷(-4.0)	TO-220

# DISCRETE SEMICONDUCTORS

## Diodes, Diodes Arrays

### • Variable Capacitance Diodes

Part	Pin to Pin Compatibility	Cd, pF	Cd ratio min	Vrmax, V	Ir, $\mu$ A	Q min	Package
KB109A, АГ, АТ/А9, АГ9, АТ9 KB109Б, БГ, БТ/Б9, БГ9, БТ9 KB109В, ВГ, ВТ/В9, ВГ9, ВТ9 KB109Г/Г9 KB109Д/Д9 KB109Е, ЕГ, ЕТ/Е9, ЕГ9, ЕТ9 KB109Ж, ЖГ, ЖТ/Ж9, ЖГ9, ЖТ9	BB417	2.24÷2.74 2.0 ÷2.3 1.9 ÷3.1 8.0 ÷17.0 7.0 ÷16.0 2.0 ÷2.3 1.8 ÷2.8	4.0÷5.5 4.5÷6.5 4.0÷6.0 4.0 2.2 4.5÷6.0 4.0÷6.0	28	0.5 0.5 0.5 0.5 0.5 0.02 0.02	300 300 160 160 30 450 300	КД-17 / SOT-23
KB121A, АГ, АТ/А9, АГ9, АТ9 KB121Б, БГ, БТ/Б9, БГ9, БТ9 KB121В, ВГ, ВТ/В9, ВГ9, ВТ9	BB909	4.3÷6.0	7.6	30	0.5 0.5 0.02	200 150 240	КД-17 / SOT-23
KB122A, АГ, АТ/А9, АГ9, АТ9 KB122Б, БГ, БТ/Б9, БГ9, БТ9 KB122В, ВГ, ВТ/В9, ВГ9, ВТ9	BB240	2.24÷2.74 2.0 ÷2.3 1.9 ÷3.1	4.0÷5.5 4.5÷6.5 4.0÷6.0	30	0.2 0.02 0.2	450 450 300	КД-17 / SOT-23
KB131A2, AP2, AT2	BB112	440÷530	18.0	14	0.25	130	SOT-23
KB134A1, AP1, AT1		18÷22	3.0	23	0.05	400	SOT-23
KB153A9 KB153Б9	BB515	1.85÷2.25 1.80÷2.60	8.0÷9.6 7.6÷10.0	30	0.02	400 360	SOT-23
KB155A9 KB155Б9	BB620	2.9÷3.4 2.6÷3.3	19.5÷25.0 18.0÷25.0	30	0.02	245	SOT-23

### • Switching Diode Arrays

Part	Pin to Pin Compatibility	Vr max, V	If max, mA	Vf, V	Trr, ns	Ir, $\mu$ A	Number of elements	Circuit	Package
КД629AC9	BAY84	90	200	1.0	100	0.1	2	Two serial connected diodes	SOT-23
КД704AC9	BAV70	70	100	1.3	6.0	5.0	2	Common cathode	SOT-23

### • Variable Capacitance Diode Arrays

Part	Pin to Pin Compatibility	Cd, pF	Cd ratio min	Vr max, V	Ir, $\mu$ A	Q min	Number of elements	Circuit	Package
KBC111A2	BB204	29.7...36.3	2.1	30	1	200	2	Common cathode	TO-92

### • Power Diode Arrays

Part	Pin to Pin Compatibility	Vr max, V	If max, A	Vf, V	t <sub>rr</sub> , ns	Ir, $\mu$ A	Number of elements	Circuit	Package
КД638AC	BYV16-200T	200	2×8.0	1.25	≤35	5.0	2	Common cathode	TO-220
КД642AC	10JTF20	200	2×10.0	1.20	≤50	100	2	Common anode	TO-220
КД667AC	MUR3040PT	400	2×15.0	1.25	≤60	10.0	2	Common cathode	TO-220
КД668AC9	TUP2200	200	2×2.0	1.25	≤35	5.0	2	Common cathode	DPAK
КД669AC91	TUP2600	600	2×2.0	1.5	≤50	10.0	2	Common cathode	DPAK
КД670AC9	MUR1660	600	2×8.0	1.5	≤60	10.0	2	Common cathode	D2PAK
КД645A	MUR860	600	8.0	1.5	≤60	10.0	1		TO-220

## • Power Schottky Diode

Part	Pin to Pin Compatibility	If max, A	If p, A	Vr p max, V	Vf, V	If, A	Ir max, mA	Package
КДШ2101А-5	SB140	1	40	40	0.57	1	0.5	Chip
КДШ2101Б-5	SB160	1	40	60	0.66	1	0.5	
КДШ2101В-5	SB1100	1	40	100	0.97	1	0.5	
КДШ2102А-5	SB240	2	50	40	0.52	2	0.5	Chip
КДШ2102Б-5	SB260	2	50	60	0.66	2	0.5	
КДШ2102В-5	SB2100	2	50	100	0.77	2	0.5	
КДШ2103А-5	SB340	3	150	40	0.55	3	0.5	Chip
КДШ2103Б-5	SB360	3	150	60	0.58	3	0.5	
КДШ2103В-5	SB3100	3	150	100	0.85	3	0.6	
КДШ2104А-5	SB540	5	250	40	0.55	5	0.5	Chip
КДШ2104Б-5	SB560	5	250	60	0.67	5	0.5	
КДШ2104В-5	SB5100	5	250	100	0.8	5	0.6	
КДШ2105В	1N5819	1.0	10	40	0.60/0.80	1/2	1.0	TO-92
КДШ2114АС9	6CWQ06F	2x3	42	60	0.58/0.79	3/6	3.0	DPAK
КДШ2114БС9	6CWQ04F	2x3	42	40	0.55/0.71	3/6	3.0	
КДШ2114ВС9	6CWQ10F	2x3	42	100	0.85/1.05	3/6	3.0	
КДШ2963АС	PBYL1025	2x10	200	30	0.49/0.58	10/20	1.5	TO-220AB
КДШ2964А	12TQ060	15	220	60	0.62/0.82	15/30	0.8	TO-220AC
КДШ2964Б	12TQ045	15	250	45	0.56/0.71	15/30	1.75	
КДШ2965А	20TQ060	20	350	60	0.64/0.84	20/40	1.8	TO-220AC
КДШ2965Б	20TQ045	20	400	45	0.57/0.73	20/40	2.7	
КДШ2966А	SC200S45	50	1150	45	0.65	50	5.0	TO-220AB
КДШ2968АС	25CTQ045	2x15	250	45	0.56/0.71	15/30	1.5	
КДШ2968БС	30CTQ060	2x15	250	60	0.62/0.82	15/30	1.5	
КДШ2968ВС		2x15	250	100	0.8/1.05	15/30	1.5	
КД2970В	MBR1045	10	150	45	0.63/0.75	10/20	0.8	TO-220AC
КД2970Б	MBR1060	10	150	60	0.68/0.86	10/20	0.8	
КД2970А	MBR10100	10	150	100	0.85/1.05	10/20	0.8	TO-220AB
КДШ297АС	MBR1545	2x7.5	150	45	0.55/0.70	7.5/15	0.8	
КДШ297БС	MBR1560	2x7.5	150	60	0.67/0.85	7.5/15	0.8	
КДШ297ВС	MBR15100	2x7.5	150	100	0.80/1.0	7.5/15	0.8	
КДШ298АС	15CTQ45	2x5	120	45	0.55/0.71	5/10	0.8	TO-220AB
КДШ298БС		2x5	120	60	0.67/0.85	5/10	1.0	
КДШ298ВС		2x5	120	100	0.80/1.05	5/10	1.0	TO-220AB
КД643АС	MBR2045	2x10	150	45	0.63/0.75	10/20	0.8	
КД643БС	MBR2060	2x10	150	60	0.68/0.86	10/20	0.8	
КД643ВС	MBR20100	2x10	150	100	0.85/1.05	10/20	0.8	
КДШ297АС91	MBRB1545	2x7.5	150	45	0.55/0.70	7.5/15	0.8	D2PAK
КДШ297БС91	MBRB1560	2x7.5	150	60	0.67/0.85	7.5/15	0.8	
КДШ297ВС91	MBRB15100	2x7.5	150	100	0.80/1.0	7.5/15	0.8	
КД643АС91	MBRB2045	2x10	150	45	0.63/0.75	10/20	0.8	
КД643БС91	MBRB2060	2x10	150	60	0.68/0.86	10/20	0.8	
КД643ВС91	MBRB20100	2x10	150	100	0.85/1.05	10/20	0.8	

Circuit - Common cathode

# DISCRETE SEMICONDUCTORS

## Thyristors and Triacs

### • Power Thyristors and Triacs

Part	Pin to Pin Compatibility	Repetitive Peak Off-State Voltages $V_{DRM}$ , $V_{RRM}$ V	RMS On-State Current	$I^2t$ for Fusing	Off-State Leakage Current	Holding Current	Latching Current	Gate Trigger Current	Peak Gate Current	Package
			$I_T (RMS)$ A	$I^2t$ , A <sup>2</sup> c	$I_D, I_R$ mA	$I_H$ mA	$I_L$ mA	$I_{GT}$ mA	$I_{GM}$ A	
<b>Thyristor</b> KY405A KY405B	BT300-600R BT300-800R	600 800	8.0	21	≤0.5	≤100	≤120	≤30	2.0	TO-220AB
KY713A KY713B		600 800	40	1060	≤0.1	≤100	≤100	≤50	4.0	TO-218
KY714A KY714B		1200 1600	25	265	≤0.2	≤80	≤100	≤60	2.0	TO-218
KY251A KY251B	MCR100-8 KY251B	600 800	1.0	0.415	≤0.05	≤10	≤5	≤0.2	≤1.0	TO-92
<b>Triac</b> KY613A KY613B	BTA208-600B BTA208-800B	600 800	8.0	21	≤0.5	≤90	≤60	≤50	2.0	TO-220AB
KY903A KY903B		600 800	40	880	≤0.1	≤80	≤100	≤50	8.0	TO-218
KY904A KY904B		1200 1600	25	265	≤0.2	≤100	≤120	≤100	2.0	TO-218
KY616A KY616B	BTA201-600ER BTA201-800ER	600 800	1.0	0.32	≤0.05	≤10	≤10	≤10	≤0.5	TO-92

• Voltage Regulators

Part	Pin to Pin Compatibility	Output Voltage, V	Output Current, A	Output Voltage Tolerance, %	Tested Operating Junction Temp. Range, °C	Package
------	--------------------------	-------------------	-------------------	-----------------------------	-------------------------------------------	---------

**Positive Voltage Regulators**

KP1180EHXXA KP1180EHXXБ KP1180EHXXB	78XXAC 78XXC 78XXB	5; 6; 8; 9; 10; 12; 15; 18; 20; 24	1.0	2 4 4	Tj= -10...+125 Tj= -10...+125 Tj= -45...+125	TO-220
K1261EHXXΠ	78FXX	5; 6; 8; 9;10;12;15;18;24	1.0	4	Tj= -10...+125	TO-126
KP1181EHXXA KP1181EHXXБ	78LXXAC 78LXXC	5; 6; 8; 9; 12; 15; 18; 24	0.1	5 10	Tj= -10...+125	TO-92

**Positive Low Dropout Regulators**

IL2931Z-X IL2931AZ-X	LM2931Z-X LM2931AZ-X	3.3; 5.0; 9.0	0.1	5 3.8	Tj= -40...+125	TO-92 TO-220
IL2940CT-5	LM2940CT-5	5.0	1.0	3	Tj= -10...+125	TO-220
IL2940CT-12	LM2940CT-12	12.0	1.0	3	Tj= -10...+125	TO-220
IL78RXX	KA78RXX	3.3; 5; 8; 9; 12; 15	1.0	2.5	Tj= -20...+80	TO-220
IL1117A-XX	AMS1117A-XX	1.2; 1.25; 1.5; 1.8; 2.5; 2.85; 3.3; 5	1.0	1.5	Tj= -40...+125	TO-220 TO-126
K1283EHXX	UR233-XX	1.2; 1.25; 1.5; 1.8; 2.5; 2.85; 3.3; 5	0.8	1.5	Tj= -40...+125	TO-220 TO-126
IL2954IT-3.3	LM2954IT-3.3	3.3	0.250	1	Tj= -40...+125	TO-220
IL2940IT-5.0	LM2940IT-5.0	5.0	0.250	1	Tj= -40...+125	TO-220
IL3480-X	LM3480	3.3; 5.0	0.1	4	Tj= -10...+125	TO-92
K1282EHXX	LT1084-XX	1.25; 1.5; 1.8; 2.5; 2.85; 3.3; 3.6; 5.0	5.0	1.5	Tj= -10...+125	TO-220
IL1085-X	LT1085	1.25; 1.5; 1.8; 2.5; 2.85; 3.3; 3.6; 5.0	3.0	1.5	Tj= -10...+125	TO-220
K1234EH3AΠ	LT1086-3.3	3.3	1.5	2	Tj=-10...+125	TO-220

**Negative Regulators**

KP1179EHXXA KP1179EHXXБ KP1179EHXXB	IL79XXAC IL79XXC IL79XXB	5; 6; 8; 9; 12; 15; 18; 20; 24	1.0	2 4 4	Tj= -10...+125 Tj= -10...+125 Tj= -45...+125	TO-220
KP1199EHXXA KP1199EHXXБ	79LXXAC 79LXXC	5; 6; 8; 9; 12; 15; 18; 24	0.1	5 10	Tj= -10...+125	TO-92

**Adjustable Voltage Regulators**

Part	Pin to Pin Compatibility	Function	Package
K1285EP1Π	LM317L	Adjustable Output Positive Voltage Regulator 0.1 A; Tj= -40...+125°C	TO-92
IL2931CD	LM2931C	Adjustable Dropout Voltage Regulator 0.1 A; (3...24 V) Tj= -40...+125°C	SO-8

**Switching Regulator**

Part	Pin to Pin Compatibility	Function	Package
IL2596 – 3.3 IL2596 – 5 IL2596 – 12 IL2596 – ADJ	LM2596 – 3.3 LM2596 – 5 LM2596 – 12 LM2596 – ADJ	Power Converter 150kHz 3A Step-Down Voltage Regulator Tj=-40...+125°C	TO-220 AB/5

## • Precision Low Voltage Reference

Part	Pin to Pin Compatibility	Function	Features	Package
K1242EP1	TL431	Programmable precision references. This monolithic IC voltage references operate as a low temperature coefficient zener which is programmable from $U_{ref}$ to 37 with two external resistors. The characteristics of these references make them excellent replacements for zener diodes in many applications such as digital voltmeters, power supplies, and operation amplifier circuitry.	<ul style="list-style-type: none"> <li>□ <math>V_{ref} = 2.5...37 V</math></li> <li>□ <math>I_k \max = 100 mA</math></li> <li>□ Shunt Reference Dynamic</li> <li>□ Impedance <math>Z \leq 0.5 \Omega</math></li> <li>□ Tolerance 0.5%; 1%; 2%</li> </ul>	TO-92 SOT-23 SO-8
K142EP2ПИМ	TL432	Programmable precision references. This monolithic IC voltage references operate as a low temperature coefficient zener which is programmable from $U_{ref}$ to 16 with two external resistors. The characteristics of these references make them excellent replacements for zener diodes in many applications such as digital voltmeters, power supplies, and operation amplifier circuitry.	<ul style="list-style-type: none"> <li>□ <math>V_{ref} = 1.24...16V</math></li> <li>□ <math>I_{kmax} = 100 mA</math></li> <li>□ Shunt Reference Dynamic</li> <li>□ Impedance <math>Z \leq 0.5 \Omega</math></li> <li>□ Tolerance 0.5%; 1%</li> </ul>	TO-92

## • Voltage Detectors

Part	Pin to Pin Compatibility	Function	Package
K1274СПХХП	K1A70XX	Voltage Detector $U_{cc \max} = 15 V$ ; $I_{OL \max} < 16 mA$ ; $U_S = 2.1/2.3/2.5/2.9/ 3.3/ 3.6/3.7/ 3.9/ 4.2/ 4.5 V$	TO-92

## • Melody IC

Part	Maximum Number of Tunes (Notes)	Vcc V	Icc, $\mu A$		Package
			Tune Play	Stop	
BT8028-XX	16 (64)	1.3 – 3.3	60	0.5	TO-92
BT8031-XX	2 (127)	1.3 – 3.3	1.0	0.5	TO-92

XX – Melody code

## • ICs for Television

Part	Pin to Pin Compatibility	Function	Characteristics	Package
ЭКР1087ЕУ1	TDA4605-02	Control IC for SMPS Using MOS-Transistors	$V_{CC} = 8.0 \div 14 \text{ V}$ Consumption Current - at start-up $\leq 1.5 \text{ mA}$ - on-state $\leq 6.0 \text{ mA}$	DIP-8
K1033EY25P K1033EY25T	UC3843	Current Mode PWM Controller	$V_{CC} = 7.0 \div 25 \text{ V}$ Consumption Current - before turn on $\leq 1.0 \text{ mA}$ - after turn on $\leq 17 \text{ mA}$ Start Threshold $V_{TH(ST)} = 7.8 \div 9.0 \text{ V}$ PWM $0 \div 94\%$	DIP-8 SO-8
ЭКР1568KH1		TV Band Decoder	$V_{CC} = 10.8 \div 13.2 \text{ V}$ $I_{CC} \leq 20 \text{ mA}$ $V_O = -0.3 \div V_{CC} + 0.3 \text{ V}$	DIP-8
IL3842ANF	UC3842	Current Mode PWM Controller	$V_{CC} = 11.5 \div 25 \text{ V}$ Consumption Current - before turn on $\leq 1.0 \text{ mA}$ - after turn on $\leq 17 \text{ mA}$ Start Threshold $V_{TH(ST)} = 14.5 \div 17.5 \text{ V}$ PWM $0 \div 94\%$	DIP-8
IL3844NF	UC3844	Current Mode PWM Controller	$V_{CC} = 11.5 \div 25 \text{ V}$ Consumption Current - before turn on $\leq 1.0 \text{ mA}$ - after turn on $\leq 17 \text{ mA}$ Start Threshold $V_{TH(ST)} = 14.5 \div 17.5 \text{ V}$ PWM $0 \div 50\%$	DIP-8
IL3845NF	UC3845	Current Mode PWM Controller	$V_{CC} = 11.5 \div 25 \text{ V}$ Consumption Current: - before turn on $\leq 1.0 \text{ mA}$ - after turn on $\leq 17 \text{ mA}$ Start Threshold $V_{TH(ST)} = 7.8 \div 9.0 \text{ V}$ PWM $0 \div 50\%$	DIP-8
IL9005N		TV Band Decoder	$V_{CC} = 4.5 \div 5.5 \text{ V}$ $I_{CC} \leq 15 \text{ mA}$ $V_O = -0.3 \div V_{CC} + 0.3 \text{ V}$	DIP-8



**TSVETOTRON**

# DISCRETE SEMICONDUCTORS

## Diodes

### • Silicon Epitaxial Planar Switching Diodes

Part	V <sub>F</sub> , V	I <sub>F</sub> , mA	I <sub>r</sub> , μA	V <sub>r</sub> , V	C <sub>d</sub> , pF	Package
1N4148	1.0	10	5.0	75	4.0	DO-35
1N4147	1.0	30	5.0	30	10.0	DO-35
LL4148	1.0	10	5.0	75	4.0	SOD-80
LL4147	1.0	30	5.0	30	10.0	SOD-80

### • Zener Diodes (P<sub>max</sub>=500 mW)

Part	V <sub>z</sub> , V	I <sub>z</sub> , mA	R <sub>df</sub> max., Ω	I <sub>z</sub> , mA	I <sub>r</sub> , μA	V <sub>r</sub> , V	I <sub>z</sub> max, mA	Package
BZV55-C2V7	2.7	5	85	5	10.0	1.0	135	SOD-80
BZV55-C3V0	3.0	5	85	5	4.0	1.0	125	SOD-80
BZV55-C3V3	3.3	5	85	5	2.0	1.0	115	SOD-80
BZV55-C3V6	3.6	5	85	5	2.0	1.0	105	SOD-80
BZV55-C3V9	3.9	5	85	5	2.0	1.0	95	SOD-80
BZV55-C4V3	4.3	5	75	5	1.0	1.0	90	SOD-80
BZV55-C4V7	4.7	5	60	5	0.5	1.0	85	SOD-80
BZV55-C5V1	5.1	5	35	5	0.1	1.0	80	SOD-80
BZV55-C5V6	5.6	5	25	5	0.1	1.0	70	SOD-80
BZV55-C6V2	6.2	5	10	5	0.1	2.0	64	SOD-80
BZV55-C6V8	6.8	5	8	5	0.1	3.0	58	SOD-80
BZV55-C7V5	7.5	5	7	5	0.1	5.0	53	SOD-80
BZV55-C8V2	8.2	5	7	5	0.1	6.0	47	SOD-80
BZV55-C9V1	9.1	5	10	5	0.1	7.0	43	SOD-80
BZV55-C10	10.0	5	15	5	0.1	7.5	40	SOD-80
BZV55-C11	11.0	5	20	5	0.1	8.5	36	SOD-80
BZV55-C12	12.0	5	20	5	0.1	9.0	32	SOD-80
BZX55-C2V7	2.7	5	85	5	10.0	1.0	135	DO-35
BZX55-C3V0	3.0	5	85	5	4.0	1.0	125	DO-35
BZX55-C3V3	3.3	5	85	5	2.0	1.0	115	DO-35
BZX55-C3V6	3.6	5	85	5	2.0	1.0	105	DO-35
BZX55-C3V9	3.9	5	85	5	2.0	1.0	90	DO-35
BZX55-C4V3	4.3	5	75	5	1.0	1.0	90	DO-35
BZX55-C4V7	4.7	5	60	5	0.5	1.0	85	DO-35
BZX55-C5V1	5.1	5	35	5	0.1	1.0	80	DO-35
BZX55-C5V6	5.6	5	25	5	0.1	1.0	70	DO-35
BZX55-C6V2	6.2	5	10	5	0.1	2.0	64	DO-35
BZX55-C6V8	6.8	5	8	5	0.1	3.0	58	DO-35
BZX55-C7V5	7.5	5	7	5	0.1	5.0	53	DO-35
BZX55-C8V2	8.2	5	7	5	0.1	6.0	47	DO-35
BZX55-C9V1	9.1	5	10	5	0.1	7.0	43	DO-35
BZX55-C10	10.0	5	15	5	0.1	7.5	40	DO-35
BZX55-C11	11.0	5	20	5	0.1	8.5	36	DO-35
BZX55-C12	12.0	5	20	5	0.1	9.0	32	DO-35
BZX55-C13VO	13.0	5	26	5	0.1	10.0	29	DO-35
BZX55-C15VO	15.0	5	30	5	0.1	11.0	27	DO-35
BZX55-C16VO	16.0	5	40	5	0.1	12.0	24	DO-35
BZX55-C18VO	18.0	5	50	5	0.1	14.0	21	DO-35
BZX55-C20VO	20.0	5	55	5	0.1	15.0	20	DO-35
BZX55-C22VO	22.0	5	55	5	0.1	17.0	18	DO-35
BZX55-C24VO	24.0	5	80	5	0.1	18.0	16	DO-35
BZX55-C27VO	27.0	5	80	5	0.1	20.0	14	DO-35
BZX55-C30VO	30.0	5	80	5	0.1	22.0	13	DO-35
BZX55-C33VO	33.0	5	80	5	0.1	24.0	12	DO-35
BZX55-C36VO	36.0	5	80	5	0.1	27.0	11	DO-35
BZX55-C39VO	39.0	2.5	90	2.5	0.1	28.0	10	DO-35
BZX55-C43VO	43.0	2.5	90	2.5	0.1	32.0	9.2	DO-35

# **PACKAGE OUTLINES**

# PACKAGE OUTLINES

## • 8- to 28-Pin Plastic SO (D/DW)

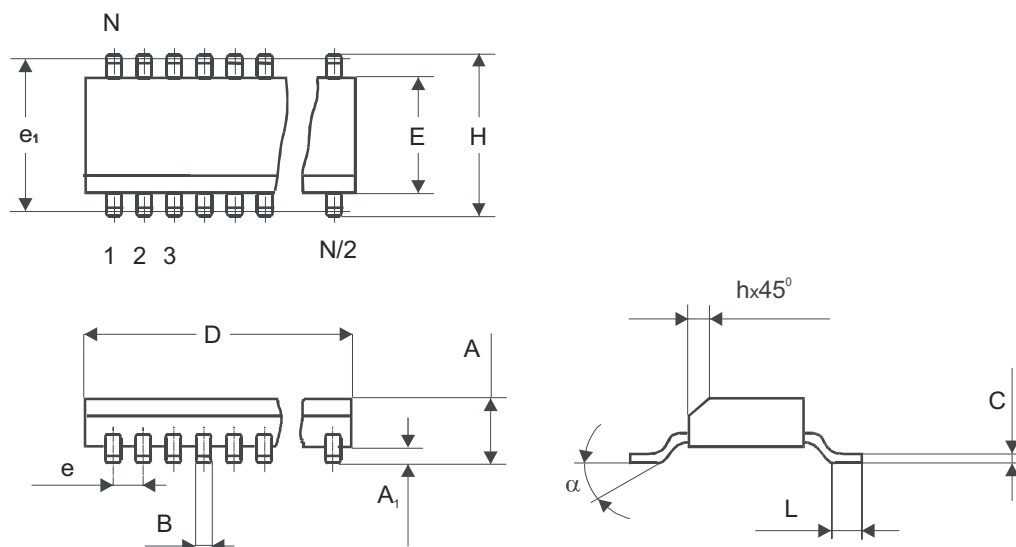

Pins, N		8	14	16	16	18	20	24	28
JEDEC Analog Suffix		MS-012AA	MS-012AB	MS-012AC	MS-013AA	MS-013AB	MS-013AC	MS-013AD	MS-013AE
Suffix		D	D	D	DW	DW	DW	DW	DW
Dimension, mm									
A	min	1.35	1.35	1.35	2.35	2.35	2.35	2.35	2.35
	max	1.75	1.75	1.75	2.65	2.65	2.65	2.65	2.65
A <sub>1</sub>	min	0.10	0.10	0.10	0.10	0.10	0.10	0.10	0.10
	max	0.25	0.25	0.25	0.30	0.30	0.30	0.30	0.30
B	min	0.33	0.33	0.33	0.33	0.33	0.33	0.33	0.33
	max	0.51	0.51	0.51	0.51	0.51	0.51	0.51	0.51
C	min	0.19	0.19	0.19	0.23	0.23	0.23	0.23	0.23
	max	0.25	0.25	0.25	0.32	0.32	0.32	0.32	0.32
D	min	4.80	8.55	9.80	10.10	11.35	12.60	15.20	17.70
	max	5.00	8.75	10.00	10.50	11.75	13.00	15.60	18.10
E	min	3.80	3.80	3.80	7.40	7.40	7.40	7.40	7.40
	max	4.00	4.00	4.00	7.60	7.60	7.60	7.60	7.60
e	nom	1.27	1.27	1.27	1.27	1.27	1.27	1.27	1.27
e <sub>1</sub>	nom	5.72	5.72	5.72	9.53	9.53	9.53	9.53	9.53
H	min	5.80	5.80	5.80	10.00	10.00	10.00	10.00	10.00
	max	6.20	6.20	6.20	10.65	10.65	10.65	10.65	10.65
h	min	0.25	0.25	0.25	0.25	0.25	0.25	0.25	0.25
	max	0.50	0.50	0.50	0.75	0.75	0.75	0.75	0.75
L	min	0.40	0.40	0.40	0.40	0.40	0.40	0.40	0.40
	max	1.27	1.27	1.27	1.27	1.27	1.27	1.27	1.27
α	min	0°	0°	0°	0°	0°	0°	0°	0°
	max	8°	8°	8°	8°	8°	8°	8°	8°

• 8- to 64-Pin Plastic Dual-in-Line (N/NS)

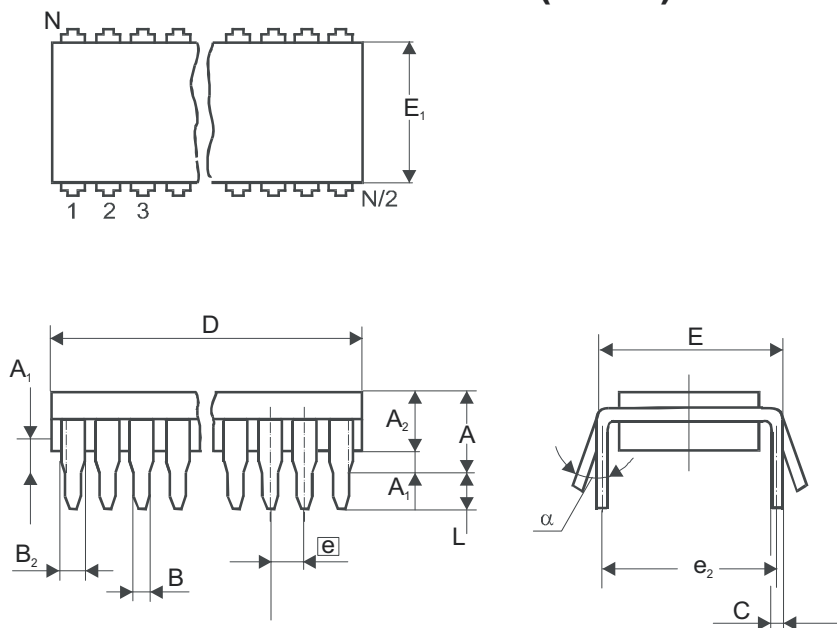

Pins, N		8	14	16	18	20	22	24	28	30	40	42	52	56	64	
JEDEC Analog		MS-001BA	MS-001AA	MS-001BB	MS-001AC	MS-001AD	MS-010AA	MS-001AF	MS-011AB	MO-026BB	MS-011AC	MS-020AB	MS-020AD	MS-020AE	SOT 274-1	
Suffix		N	N	N	N	N	N	N	N	NS	N	NS	NS	NS	NS	
Dimension, mm																
A	max	5.33	5.33	5.33	5.33	5.33	5.33	5.33	6.35	5.08	6.35	5.08	5.08	5.08	5.84	
A1	min	0.38	0.38	0.38	0.38	0.38	0.38	0.38	0.38	0.51	0.38	0.51	0.51	0.51	0.51	
A2	min	2.92	2.92	2.92	2.92	2.92	3.18	2.92	3.18	3.05	3.18	3.05	3.05	3.05	3.05	
	max	4.95	4.95	4.95	4.95	4.95	4.95	4.95	4.95	4.57	4.95	4.57	4.57	4.57	4.57	
B	min	0.36	0.36	0.36	0.36	0.36	0.36	0.36	0.36	0.36	0.36	0.38	0.38	0.38	0.4	
	max	0.56	0.56	0.56	0.56	0.56	0.56	0.56	0.56	0.58	0.56	0.56	0.56	0.56	0.53	
B2	min	1.14	1.14	1.14	1.14	1.14	1.14	1.14	0.77	0.76	0.77	0.89	0.89	0.89	0.8	
	max	1.78	1.78	1.78	1.78	1.78	1.65	1.78	1.78	1.40	1.78	1.14	1.14	1.14	1.3	
C	min	0.20	0.20	0.20	0.20	0.20	0.23	0.20	0.20	0.20	0.20	0.23	0.23	0.23	0.23	
	max	0.36	0.36	0.36	0.36	0.36	0.38	0.36	0.38	0.36	0.38	0.38	0.38	0.38	0.38	
D	min	8.51	18.67	18.67	22.35	24.89	27.05	31.24	35.10	26.67	50.30	36.58	45.72	45.72	57.7	
	max	10.16	19.69	19.69	23.37	26.92	28.45	32.51	39.70	28.49	53.20	37.08	46.23	46.23	58.67	
E	min	7.62	7.62	7.62	7.62	7.62	9.91	7.62	15.24	9.91	15.24	15.24	15.24	15.24	19.05	
	max	8.26	8.26	8.26	8.26	8.26	10.80	8.26	15.87	11.05	15.87	16.00	16.00	16.00	19.61	
E1	min	6.1	6.1	6.1	6.1	6.1	8.38	6.1	12.32	7.62	12.32	12.70	12.70	12.70	16.9	
	max	7.11	7.11	7.11	7.11	7.11	9.91	7.11	14.73	9.40	14.73	14.48	14.48	14.48	17.2	
e	nom	2.54	2.54	2.54	2.54	2.54	2.54	2.54	2.54	1.778	2.54	1.778	1.778	1.778	1.778	
e2	nom	7.62	7.62	7.62	7.62	7.62	10.16	7.62	15.24	10.16	15.24	15.24	15.24	15.24	19.05	
L	min	2.92	2.92	2.92	2.92	2.92	2.92	2.92	2.92	2.54	2.92	2.54	2.54	2.54	2.8	
	max	3.81	3.81	3.81	3.81	3.81	4.06	3.81	5.08	3.81	5.08	3.56	3.56	3.56	3.2	
alpha	min	0°	0°	0°	0°	0°	0°	0°	0°	0°	0°	0°	0°	0°	0°	
	max	10°	10°	10°	10°	10°	15°	10°	10°	10°	10°	10°	10°	15°	15°	

# PACKAGE OUTLINES

## • 24-Pin Metal Ceramic Dual-in-Line

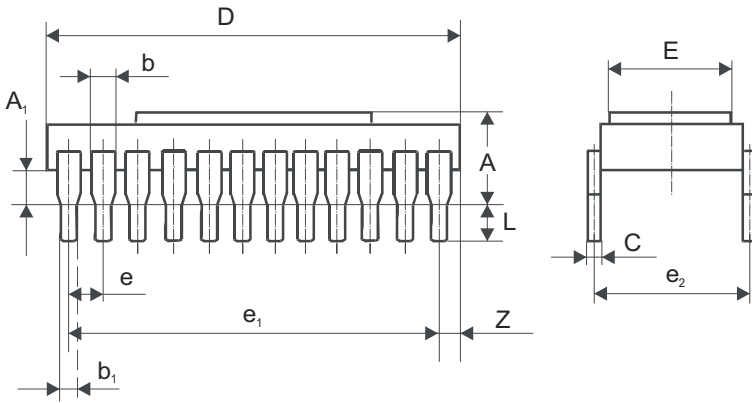

Dimension	mm	
	min	max
A		4.63
A <sub>1</sub>	0.8	1.8
b		1.5
b <sub>1</sub>	0.41	0.55
C	0.22	0.3
D	28.9	29.5
E	14.43	14.85
e	2.5	
e <sub>1</sub>	27.5	
e <sub>2</sub>	15.0	
L	3.26	3.74
Z		1.25

## • 64- Pin Quad Plastic Flat (MQFP)

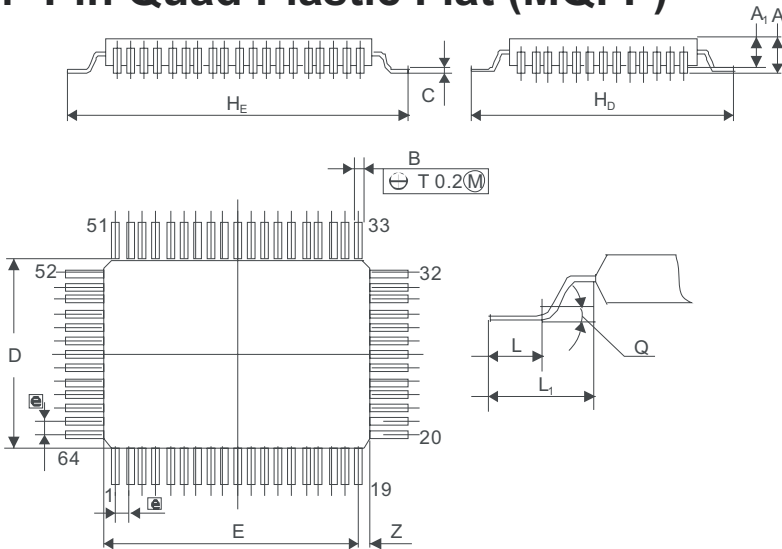

Dimension	MM	
	min	max
A		2.5
A <sub>1</sub>	2.05	
B	0.36	0.5
C	0.13	0.2
D	13.85	14.15
E	19.85	20.15
e		1.0
H <sub>D</sub>	18.9	19.5
H <sub>E</sub>	24.9	25.5
L	1.05	1.45
L <sub>1</sub>	2.4	2.8
Y		0.15
Z		1.1
Q	3°	7°

## • 28-Pin Metal Ceramic Flat

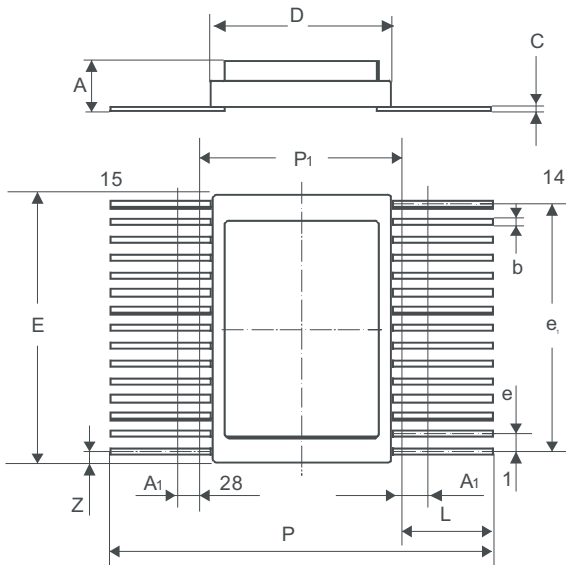

Dimension	mm	
	min	max
A	2.75	3.46
A <sub>1</sub>		0.7
b	0.31	0.45
C	0.13	0.2
D	12.43	12.7
E	18.09	18.3
e	1.25	
e <sub>1</sub>	16.25	
L	6.0	
P	25.77	26.1
P <sub>1</sub>	13.43	13.7
Z		1.05



# PACKAGE OUTLINES

## • TO-3 Jumbo

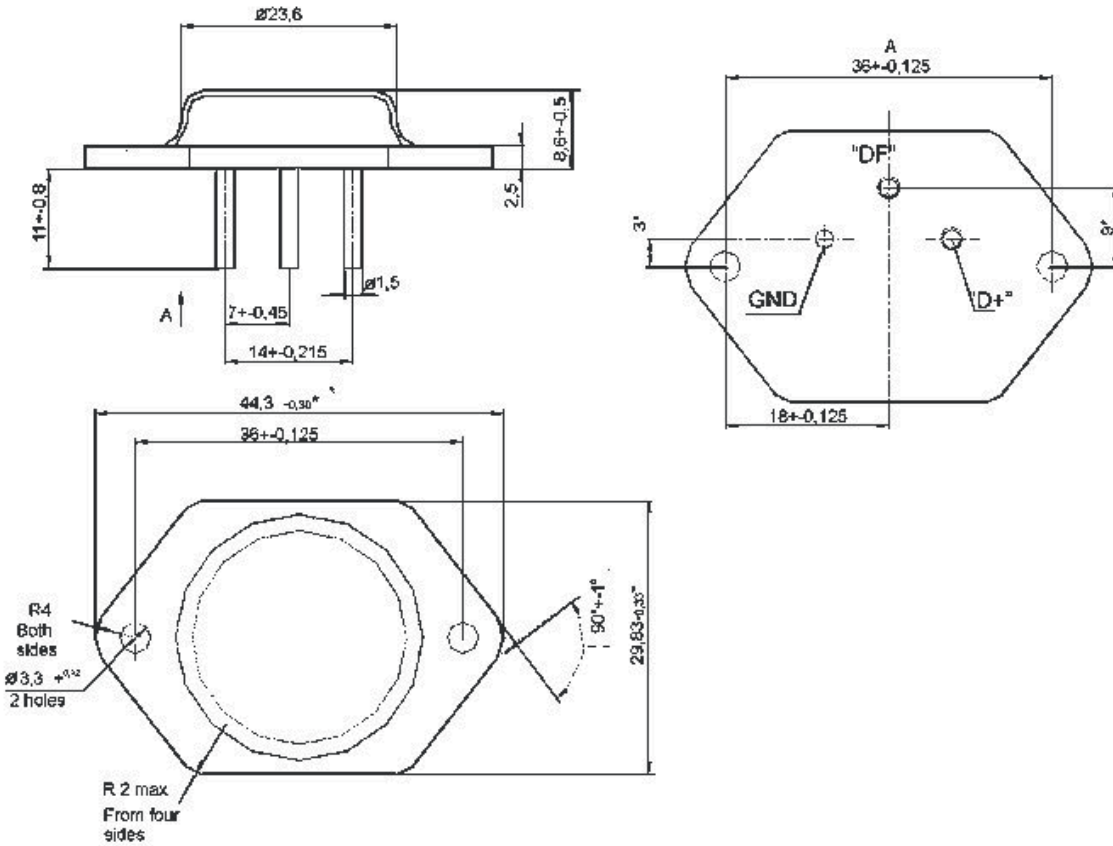

## • P-SOT223-4-1, P-SOT223-4-2

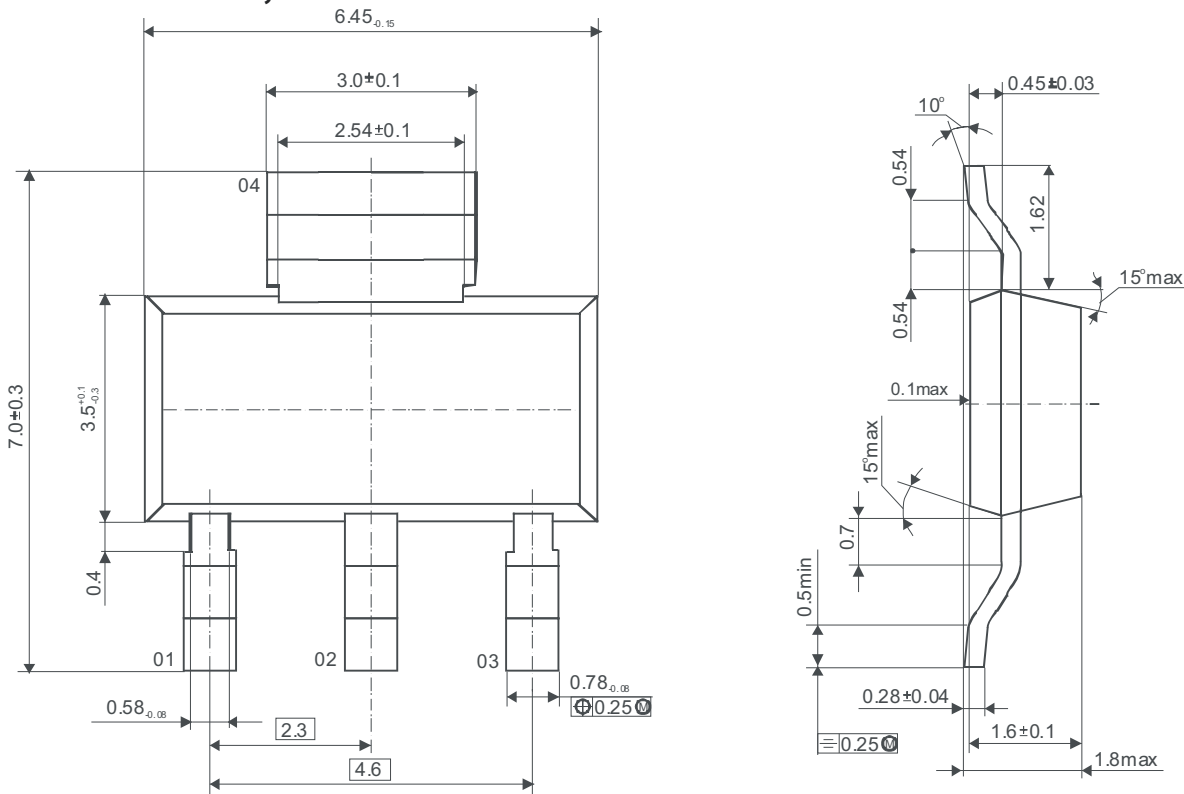

●P-TO-220-5-11 (TO-220AB/5)

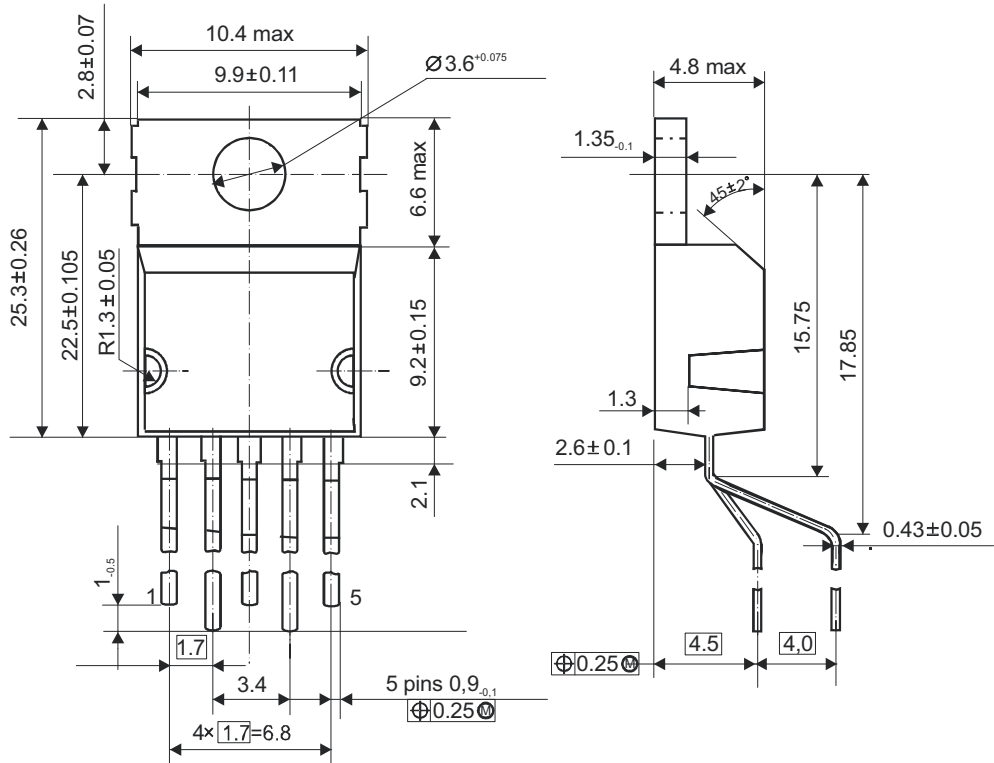

●P-TO-220-5-12

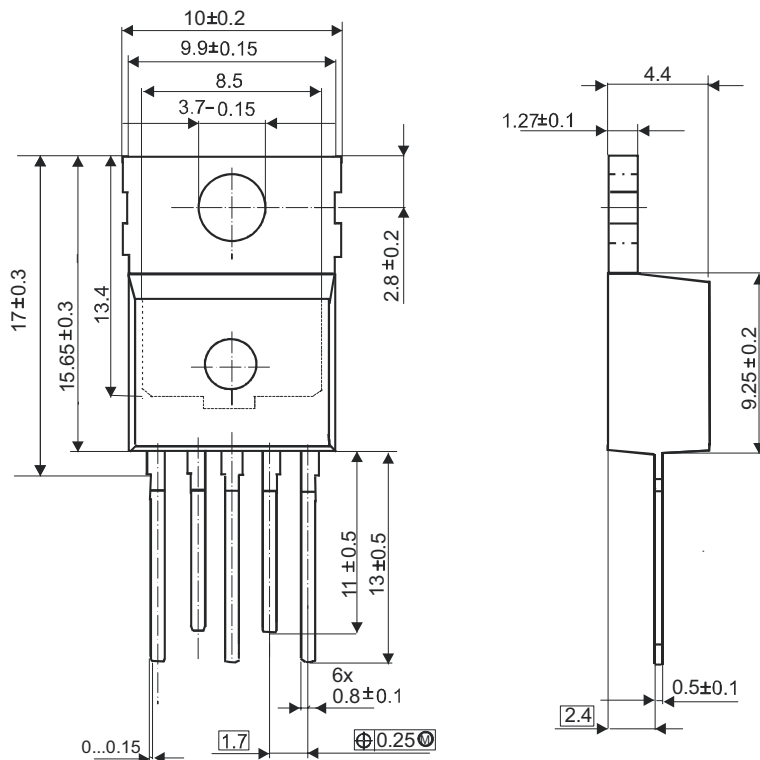



•P-TO-220-7-180

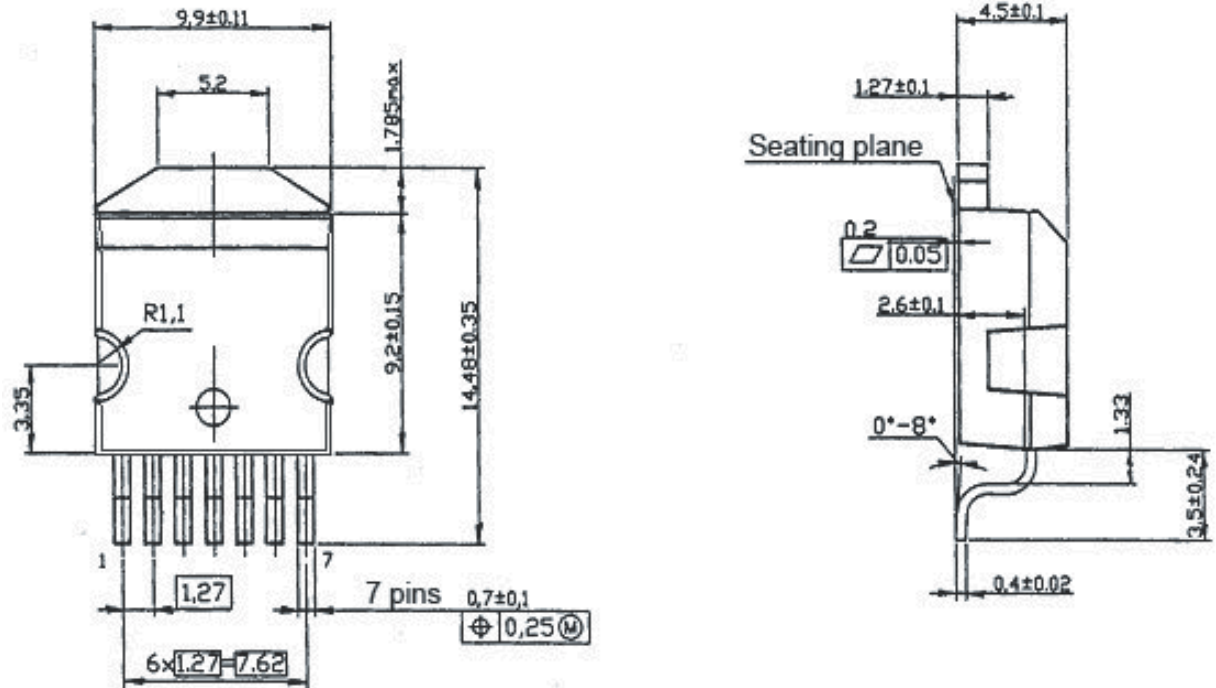

•P-TO-220-7-230

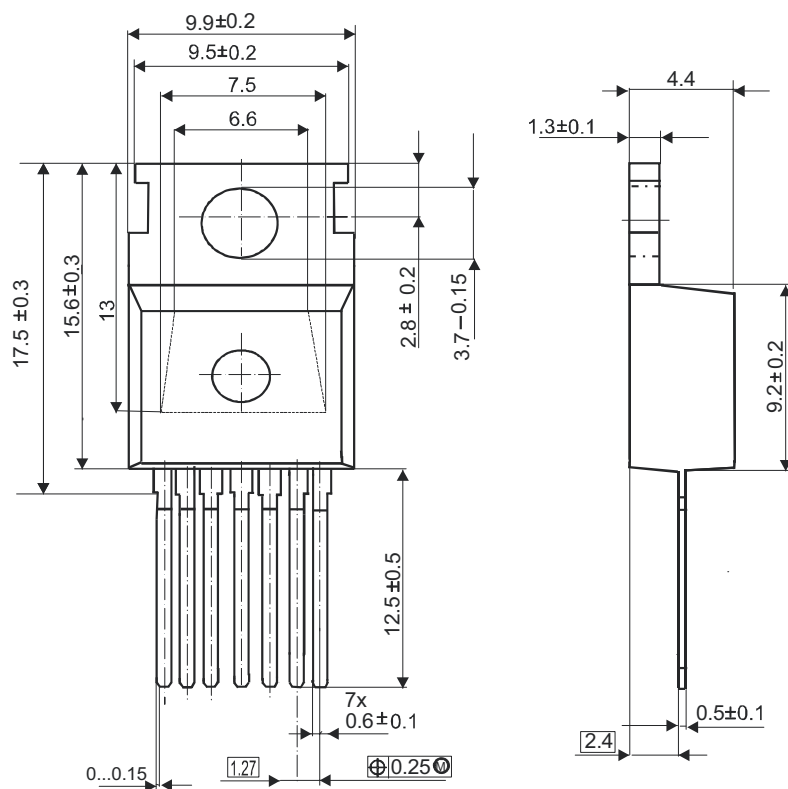

# PACKAGE OUTLINES

## • 7-Pin Plastic Power Dual-in-Line (TO-220 AB/7)

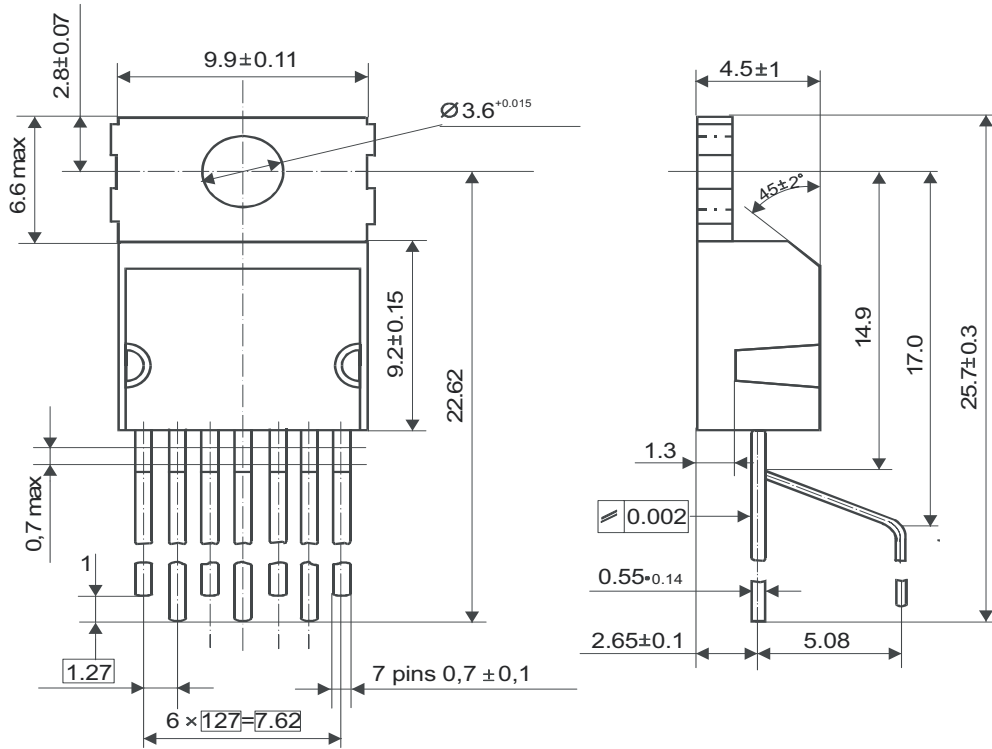

## • 9-Pin Plastic Power DIL-Bent-SIL (DBS-9P)

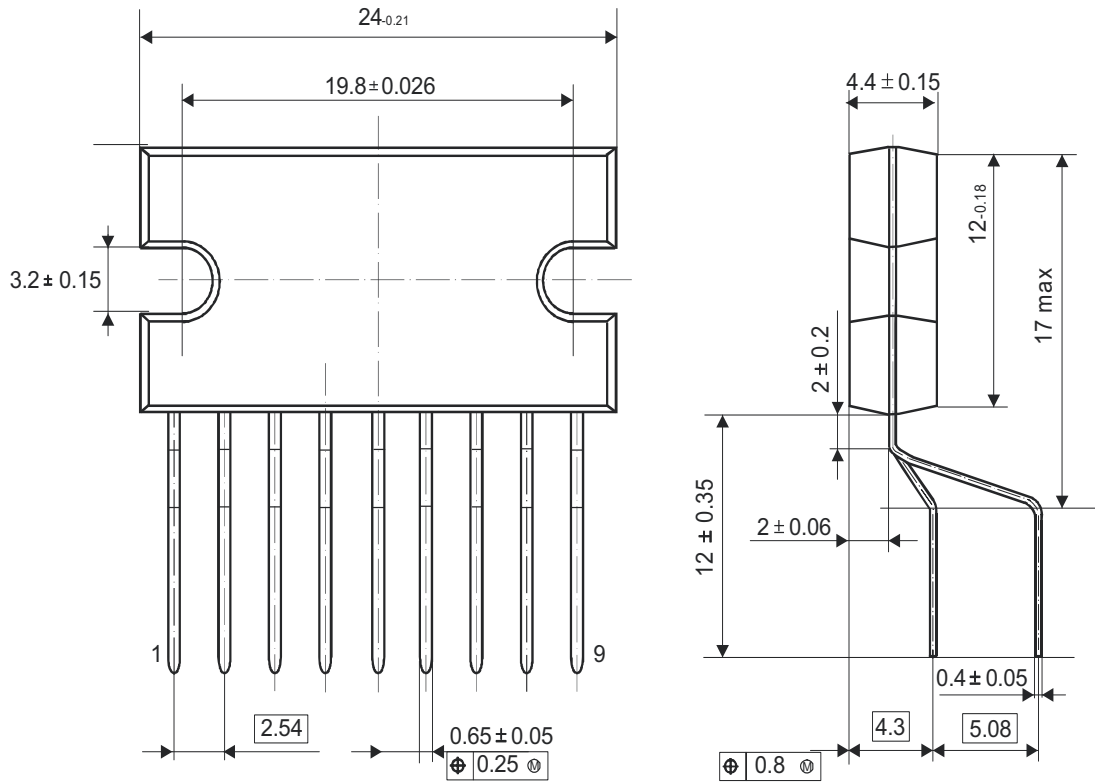

• SOT523-1

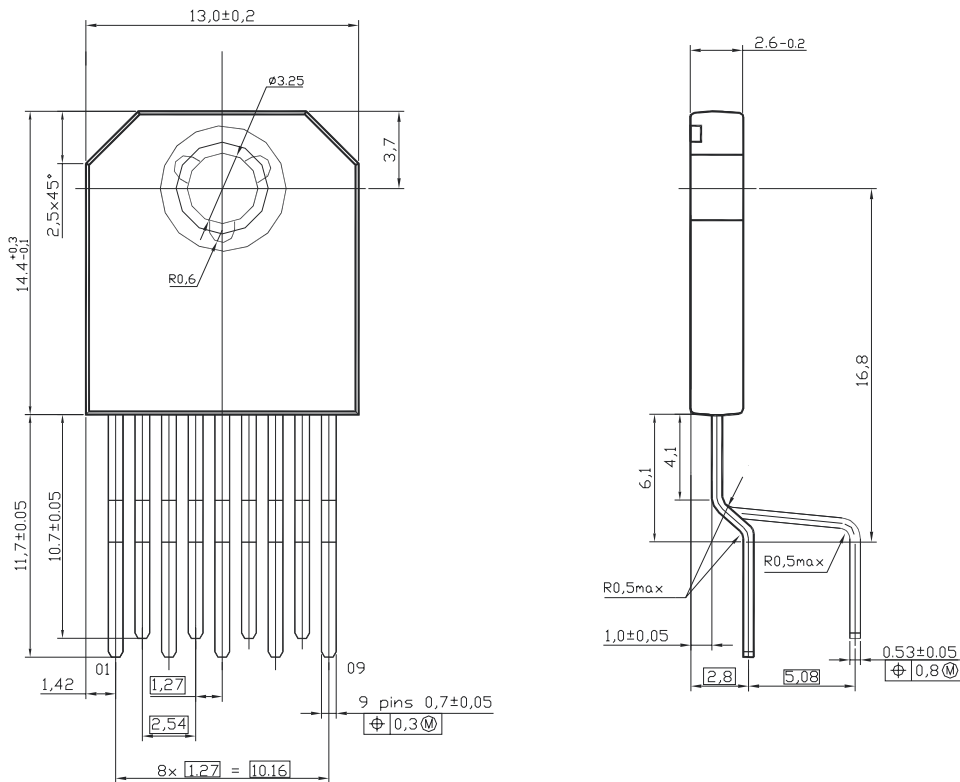

• 9-Pin Plastic Power Single-in-Line (SIL-9MPF)

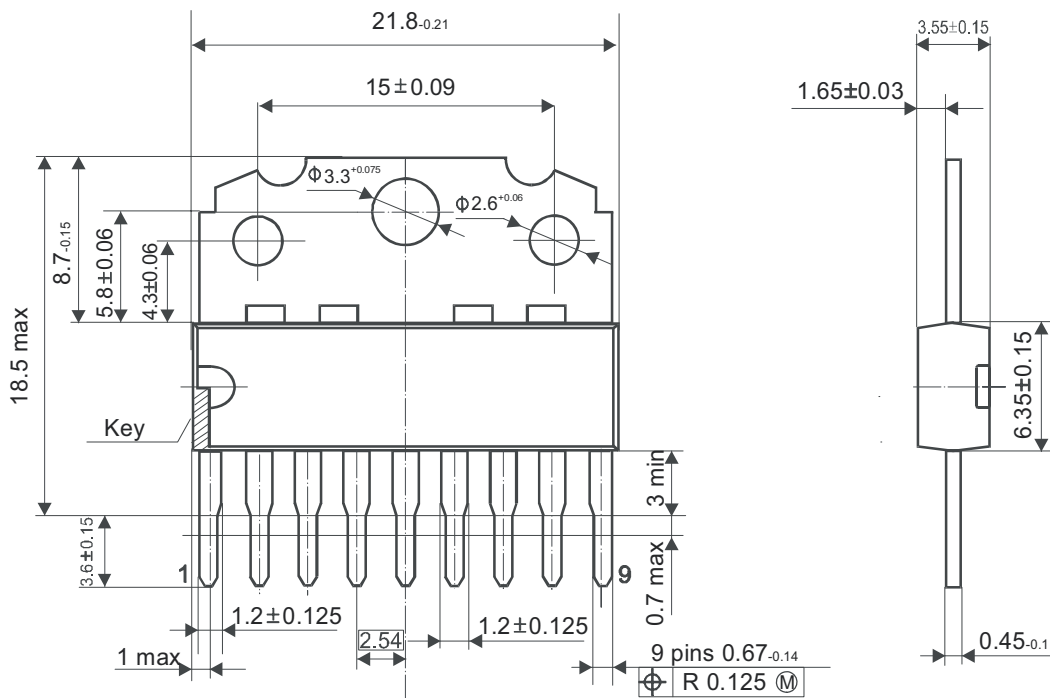

# PACKAGE OUTLINES

## ● 9-Pin Plastic Power Single-in-Line (SIL-9P)

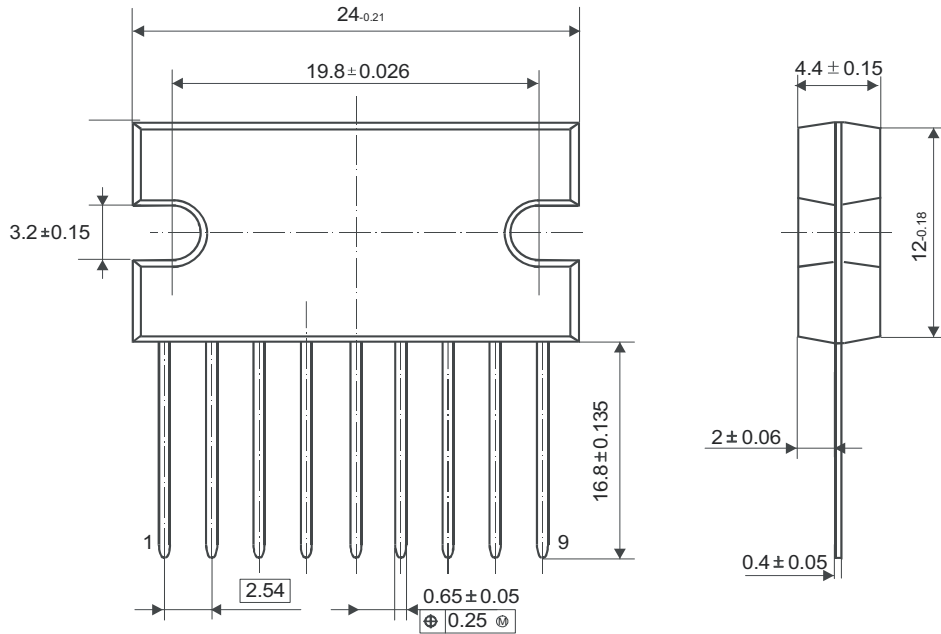

## ● 9-Pin Plastic Power DIL-Bent-SI (DBS-9MPF)

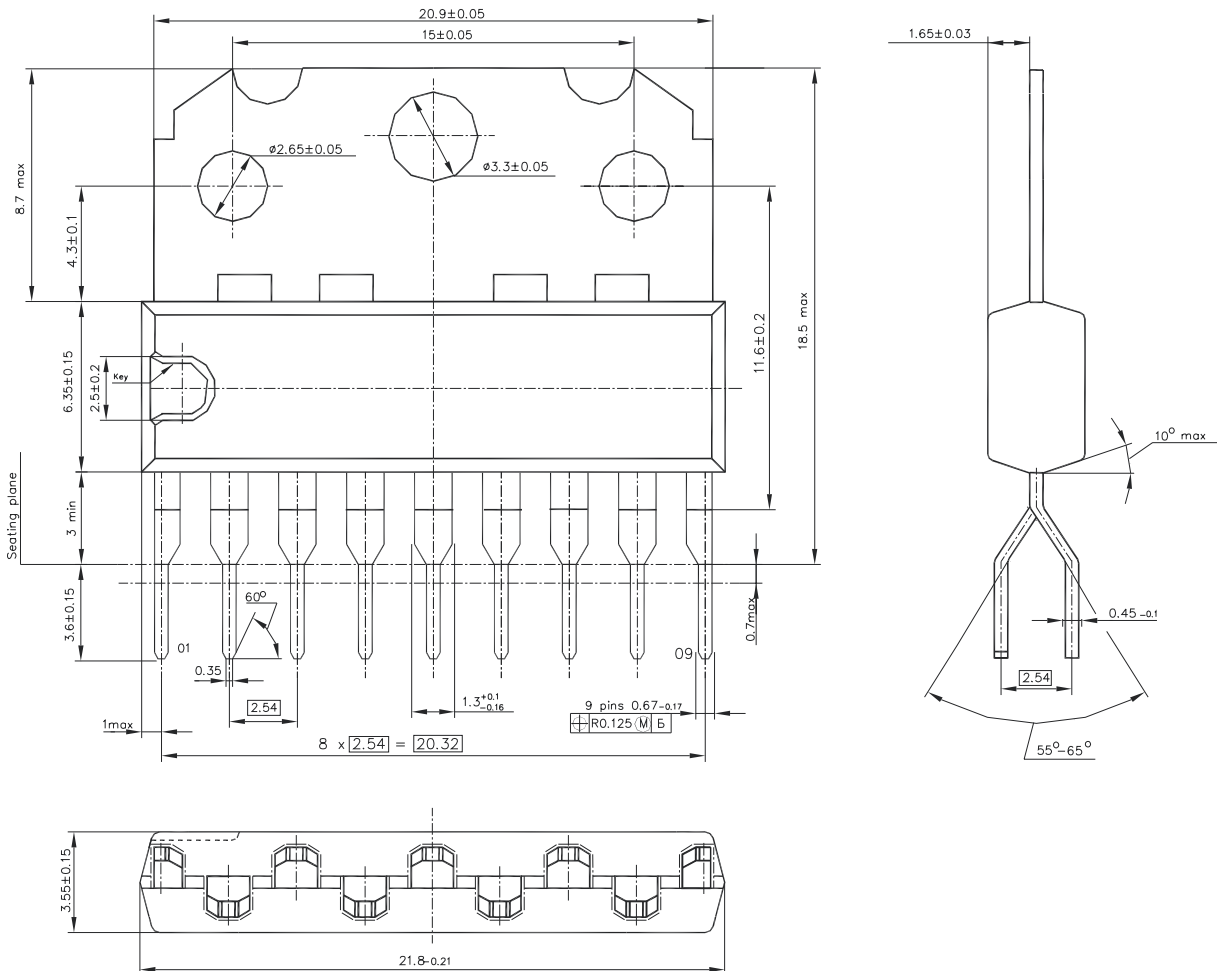

• SIL-13P

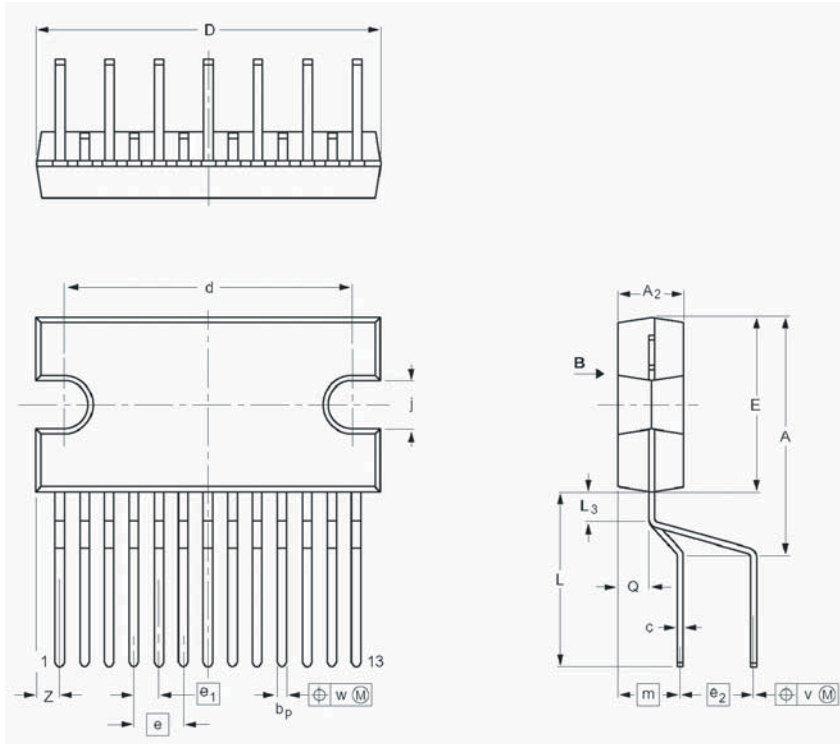

Dimension	mm	
	Min	Max
<b>A</b>	15.5	17.0
<b>A<sub>2</sub></b>	4.2	4.6
<b>bp</b>	0.60	0.75
<b>c</b>	0.38	0.48
<b>D(1)</b>	23.6	24.0
<b>d</b>	19.6	20.0
<b>Dh</b>	10	
<b>E(1)</b>	11.8	12.2
<b>e</b>	3.4	
<b>e<sub>1</sub></b>	1.7	
<b>e<sub>2</sub></b>	5.08	
<b>Eh</b>	6	
<b>j</b>	3.1	3.4
<b>L</b>	11.0	12.4
<b>L<sub>3</sub></b>	1.6	2.4
<b>m</b>	4.3	
<b>Q</b>	1.8	2.1
<b>v</b>	0.8	
<b>w</b>	0.25	
<b>x</b>	0.03	
<b>Z(1)</b>	1.45	2.00

• SIL-15P

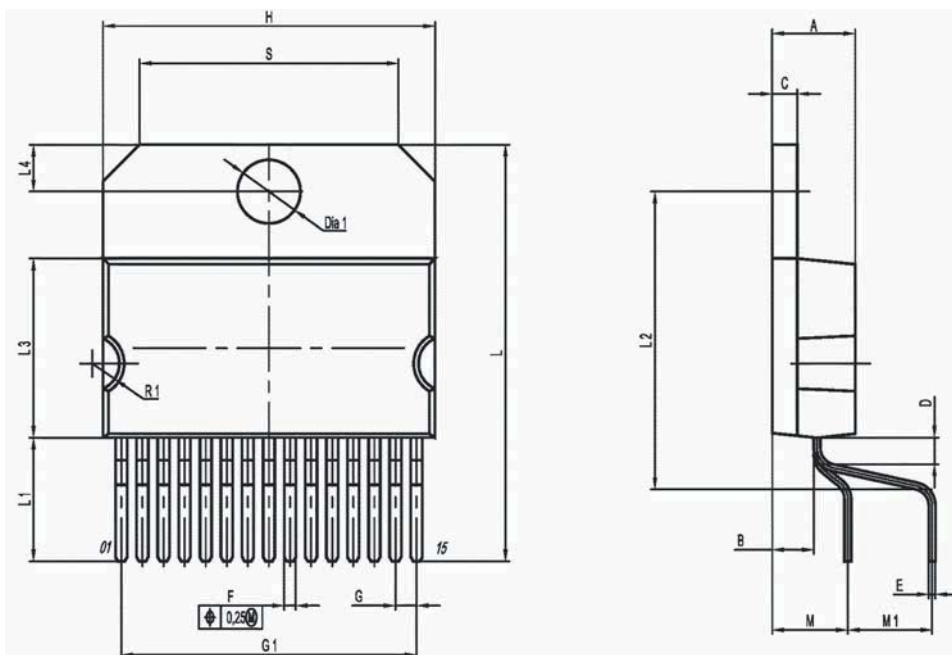

Dimension	mm	
	Min	Max
<b>A</b>	-	5.0
<b>B</b>	2.5	2.7
<b>C</b>	1.45	1.55
<b>D</b>	1.475	1.725
<b>E</b>	0.38	0.48
<b>F</b>	0.65	0.75
<b>G</b>	-	1.27
<b>G<sub>1</sub></b>	-	17.78
<b>H</b>	-	20.2
<b>L</b>	24.64	25.16
<b>L<sub>1</sub></b>	7.2	7.6
<b>L<sub>2</sub></b>	17.54	18.06
<b>L<sub>3</sub></b>	10.7	10.85
<b>L<sub>4</sub></b>	2.73	2.87
<b>M</b>	-	4.55
<b>M<sub>1</sub></b>	-	5.08
<b>S</b>	15.35	15.85
<b>Dia1</b>	3.8	3.875
<b>R1</b>	1.38	1.88

# PACKAGE OUTLINES

## • QFP-80

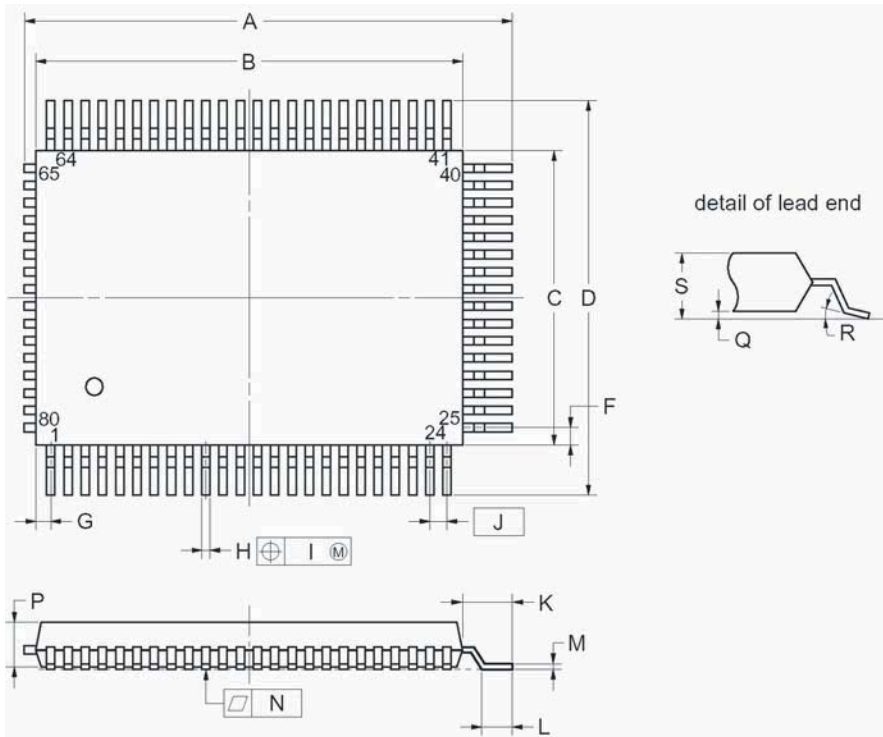

Dimension	mm	
	MIN	MAX
A	21.9	22.7
B	19.8	20.2
C	13.8	14.2
D	17.2	18.0
F	1.0	
G	0.8	
H	0.25	0.45±0.10
I	0.15	
J	0.8 (T.P.)	
K	1.6	2.0
L	0.6	1.0
M	0.15	
N	0.10	
P	2.7	
Q	0	0.2
R	0°	10°
S	-	3.0

## • QFP-100

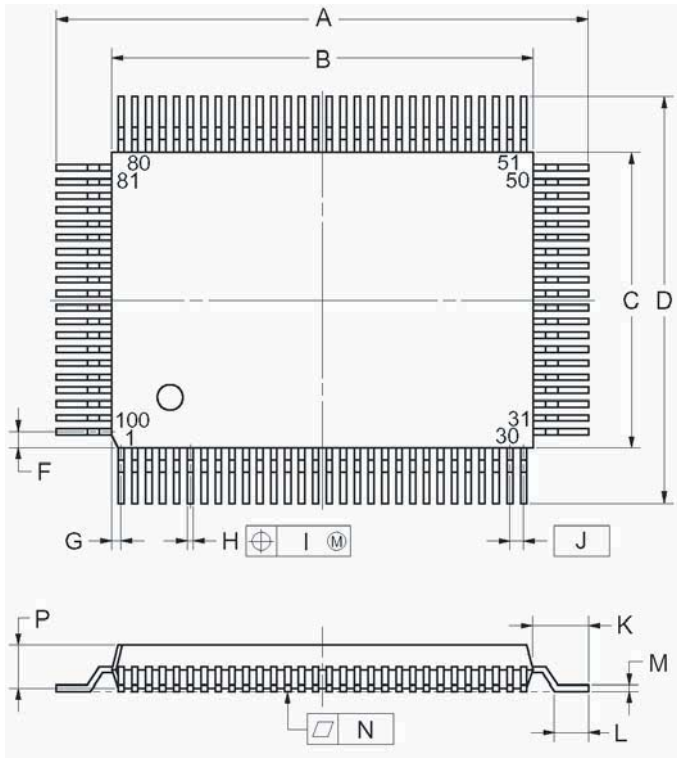

Dimension	mm	
	MIN	MAX
A	23.0	23.4
B	19.8	20.2
C	13.0±0.2	14.2
D	17.0	17.4
F	0.8	
G	0.6	
H	0.20	0.40
I	0.15	
J	0.65 (T.P.)	
K	1.4	1.8
L	0.6	1.0
M	0.05	0.25
N	0.10	
P	2.7	
Q	0.125±0.075	0.125±0.075
R	0°	10°
S	-	3.0

• Case 22A-01

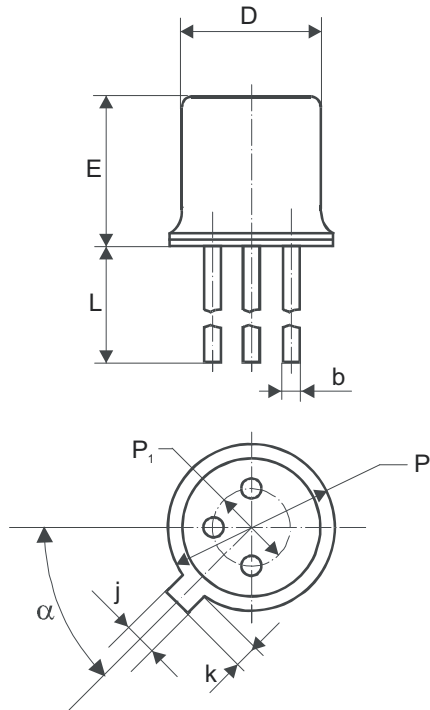

Dimension	mm	
	min	max
<b>b</b>		0.5
<b>D</b>		4.95
<b>E</b>		5.3
<b>L</b>	12.5	14.5
<b>P</b>		5.84
<b>P<sub>1</sub></b>	2.2	2.6
<b>j</b>	0.94	1.12
<b>k</b>	0.88	1.12
<b><math>\alpha</math></b>	40°	50°

• DO-35

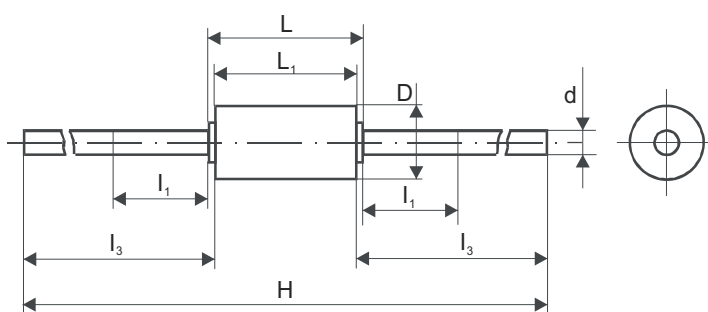

Dimension	mm	
	min	max
<b>D</b>		1.9
<b>d</b>		0.56
<b>L</b>		4.4
<b>L<sub>1</sub></b>		3.8
<b>H</b>		63.8
<b>l<sub>1</sub></b>		2.5
<b>l<sub>3</sub></b>	26.0	30.0

**Notes:**

1.  $l_1$  - Lead length is not controlled and unmounted in this zone.
2. The following type of packages exist:  
 $l_3 \geq 15 \text{ mm}$     $H \leq 34.5 \text{ mm}$  and  
 $l_3 \geq 29.6 \text{ mm}$     $H = 62.78 \pm 0.6 \text{ mm}$

# PACKAGE OUTLINES

## • MELF

Dimension	mm	
	min	max
D	2.4	2.5
d	2.3	2.4
H	4.7	5.1
L		0.4

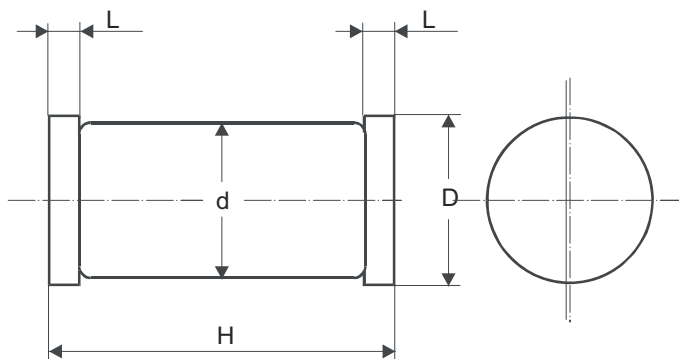

## • SOD-80 (MiniMELF)

Dimension	mm	
	min	max
D	1.6	1.7
d		1.5
H	3.3	3.7
L		0.4

## • SOT-23

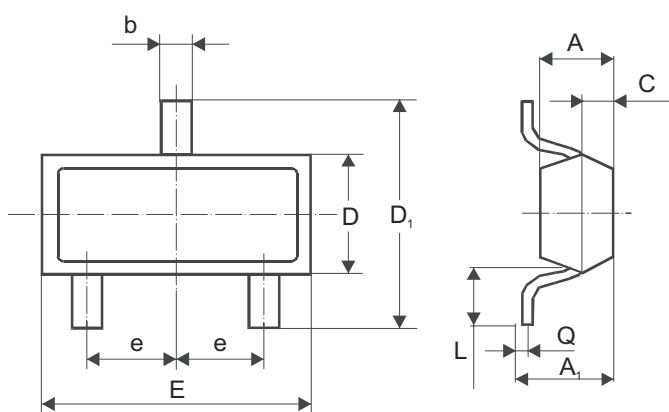

Dimension	mm	
	min	max
A	0.75	0.95
A <sub>1</sub>	0.25	1.1
b	0.38	0.46
C	0.5	0.65
D	1.2	1.4
D <sub>1</sub>	2.1	2.5
E	2.8	3.0
e	0.85	1.05
L	0.4	0.6
Q	0.09	0.15

• TO-18

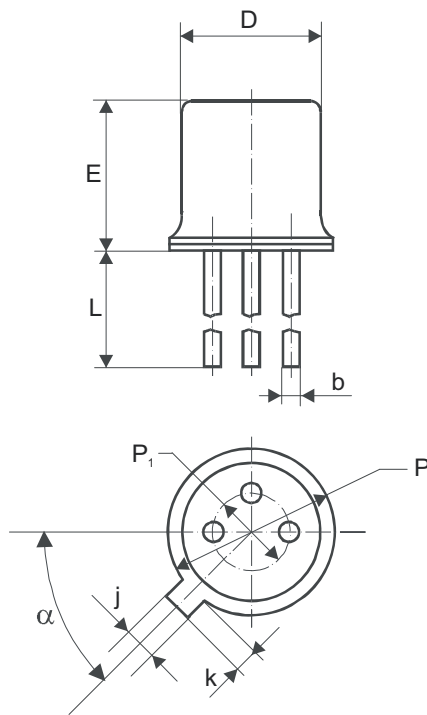

Dimension	mm	
	min	max
<b>b</b>		0.5
<b>D</b>		4.95
<b>E</b>		5.3
<b>L</b>	12.5	14.5
<b>P</b>		5.84
<b>P<sub>1</sub></b>	2.2	2.6
<b>j</b>	0.94	1.12
<b>k</b>	0.88	1.12
<b><math>\alpha</math></b>	40°	50°

• TO-72

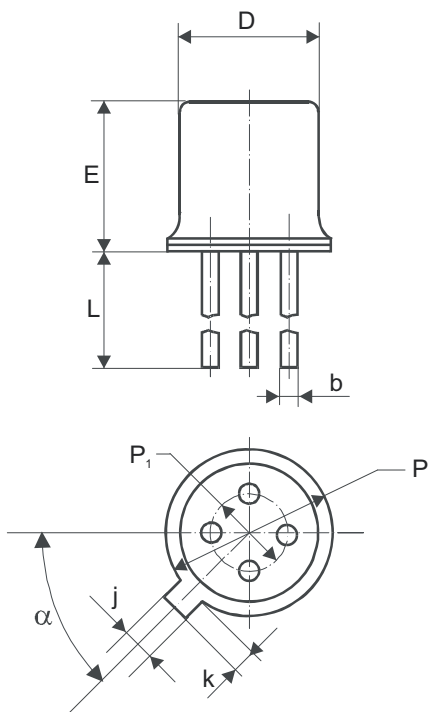

Dimension	mm	
	min	max
<b>b</b>		0.5
<b>D</b>		4.95
<b>E</b>		5.3
<b>L</b>	12.5	14.5
<b>P</b>		5.84
<b>P<sub>1</sub></b>	2.2	2.6
<b>j</b>	0.94	1.12
<b>k</b>	0.88	1.12
<b><math>\alpha</math></b>	40°	50°



• TO-218

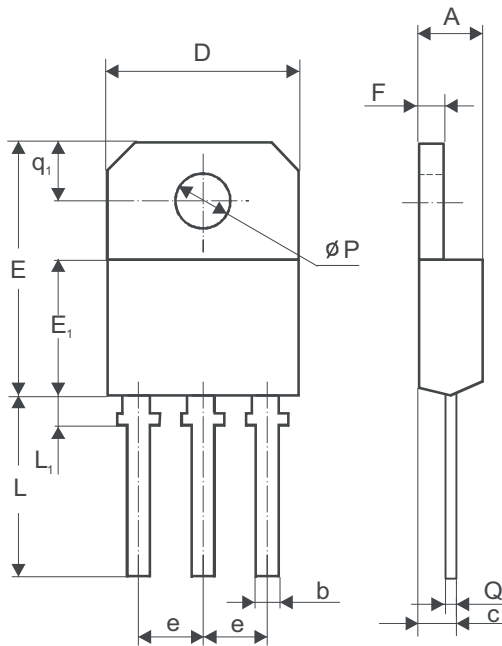

Dimension	mm	
	min	max
A	4.9	5.0
b	1.0	1.2
C	2.2	2.8
D	14.8	15.2
E	20.1	20.5
E <sub>1</sub>	12.5	12.7
e	5.4	5.6
F	1.98	2.1
L	14.0	15.0
L <sub>1</sub>	1.5	1.9
P	4.0	4.2
Q	0.5	0.6
q <sub>1</sub>	4.0	4.1

• TO-220AB

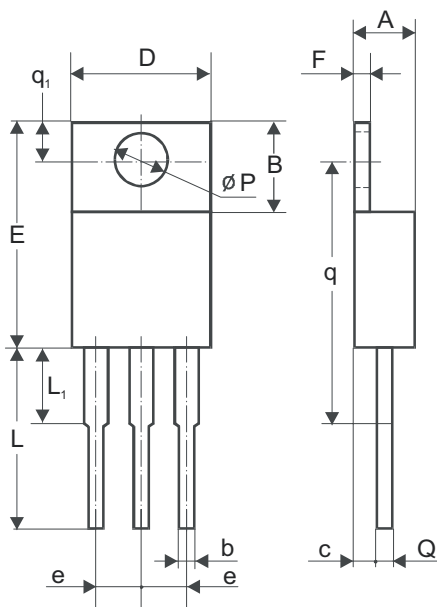

Dimension	mm	
	min	max
A	4.2	4.8
B	5.9	6.8
b	0.6	0.8
c	2.3	2.6
D	10.3	10.7
E	15.2	15.9
e	2.2	2.6
F	1.1	1.2
L	12.5	14.5
L <sub>1</sub>	3.06	3.54
P	3.6	3.72
Q	0.55	0.75
q	15.785	16.215
q <sub>1</sub>	2.6	3.0

# PACKAGE OUTLINES

## • TO-220AC

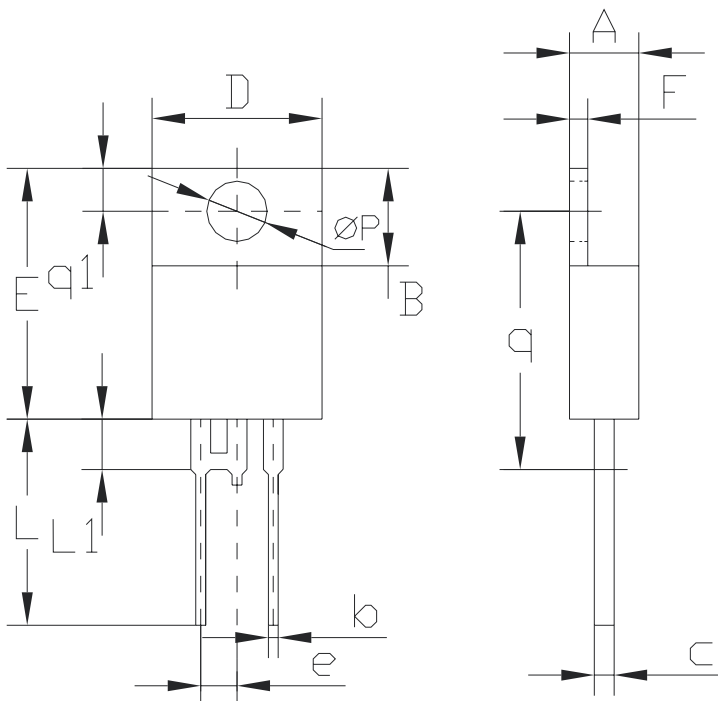

Dimension	mm	
	min	max
<b>A</b>	4.2	4.8
<b>B</b>	5.9	6.8
<b>b</b>	0.6	0.8
<b>c</b>	2.3	2.6
<b>D</b>	10.3	10.7
<b>E</b>	15.2	15.9
<b>e</b>	2.2	2.6
<b>F</b>	1.1	1.2
<b>L</b>	12.5	14.5
<b>L1</b>	3.06	3.54
<b>P</b>	3.6	3.72
<b>Q</b>	0.55	0.75
<b>q</b>	15.785	16.215
<b>q1</b>	2.6	3

• DPACK

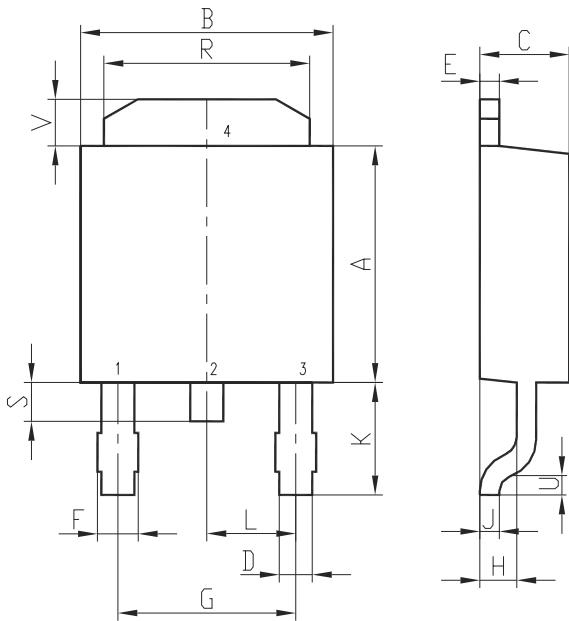

Dimension	mm	
	min	max
A	5.99	6.22
B	6.37	6.73
C	2.23	2.37
D	0.71	0.85
E	0.46	0.61
F	-	1.05
G	4.58	
H	0.9	1.0
J	0.46	0.61
K	2.65	2.9
L	2.24	2.34
R	5.21	5.39
S	0.7	1.0
U	0.51	-
V	1.15	1.25

• D2PACK

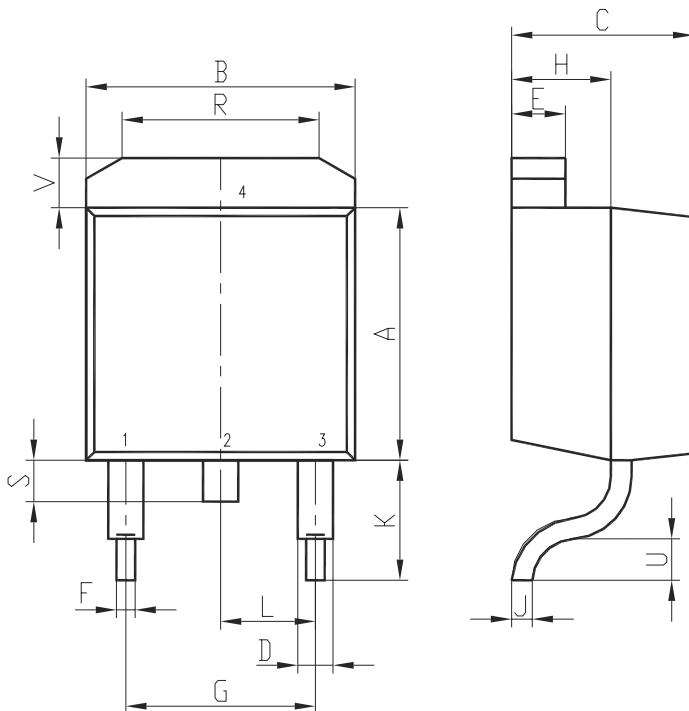

Dimension	mm	
	min	max
A	8.49	8.71
B	9.92	10.28
C	4.25	4.55
D	1.15	1.4
E	1.1	1.3
F	0.71	0.85
G	5.08	
H	2.3	2.5
J	0.46	0.6
K	4.76	5.24
L	2.54	
R	6.89	7.11
S	1.45	1.55
U	2.3	2.7
V	-	1.4

## HEADQUARTERS

### **INTEGRAL JOINT STOCK COMPANY**

12, Korzhenevskogo Str., Minsk,  
220108,  
Republic of Belarus  
Tel.: ..... (375 17) 278 4627  
..... (375 17) 278 4882  
Fax: ..... (375 17) 212 1521  
E-mail: dzvef2@integral.by  
<http://www.integral.by/>

### **MARKETING DEPARTMENT**

12, Korzhenevskogo Str., Minsk,  
220108,  
Republic of Belarus  
Tel.: ..... (375 17) 2789 963  
Fax: ..... (375 17) 2122 031  
E-mail: p\_um@integral.by

### **DEPARTMENT of FOREIGN ECONOMIC RELATIONS**

12, Korzhenevskogo Str., Minsk,  
220108,  
Republic of Belarus  
Tel.: ..... (375 17) 278 4627  
..... (375 17) 278 4882  
Fax: ..... (375 17) 212 1521  
E-mail: dz\_vef@integral.by

## MICROELECTRONICS

### **SEMICONDUCTOR DEVICES FACTORY**

subsidiary of INTEGRAL JSC  
12, Korzhenevskogo Str., Minsk,  
220108, Republic of Belarus  
Tel.: ..... (375 17) 278 4627  
marketing: ..... (375 17) 212 3051  
Fax: ..... (375 17) 278 1622  
E-mail: dzum@integral.by

### **DC BELMICROSYSTEMS**

subsidiary of INTEGRAL JSC  
12, Korzhenevskogo Str., Minsk,  
220108,  
Republic of Belarus  
Tel.: ..... (375 17) 278 6587  
..... (375 17) 212 6916  
Fax: ..... (375 17) 278 2822  
E-mail: office@bms.by  
<http://www.bms.by/>

### **TRANSISTOR**

subsidiary of INTEGRAL JSC  
16, Korzhenevskogo Str., Minsk,  
220108  
Republic of Belarus  
Tel.: ..... (375 17) 212 3802  
Fax: ..... (375 17) 278 2917  
E-mail: market@transistor.com.by  
<http://www.transistor.by/>

## DISTRIBUTORS AND REPRESENTATIVES

### **REPUBLIC OF KOREA**

**IK Semicon Co., Ltd.**  
Rm.503, DMC Hi-Tech Industrial Center, #1580,  
Sangam-Dong, Mapo-Gu, Seoul, Korea  
Tel.: ..... (822) 3153-7090  
Fax: ..... (822) 3153 7095  
E-mail: kdyoon@iksemi.com

### **CHINA**

**Representative Office of SOE Semiconductor  
Devices Factory "Integral" JSC**  
Mobile phone..... (86 13) 6816 48069  
E-mail: shanghai@integral.cn